

Single / Dual Channel Process Data Recorder

ARC 0102R

Single / Dual Universal Analog Input Channels
Huge Built-in Memory : 2,29,376 Records
Selectable PC / Pen-Drive Record Transfer Options
4 Rows of 20 Characters LCD Display with Back-Light LED
¼ DIN (96 x 96) Compact Enclosure

Process Precision Instruments
Vasai Road (E), Dist. Palghar - 401210,
Maharashtra, India

www.ppiindia.net

User Manual

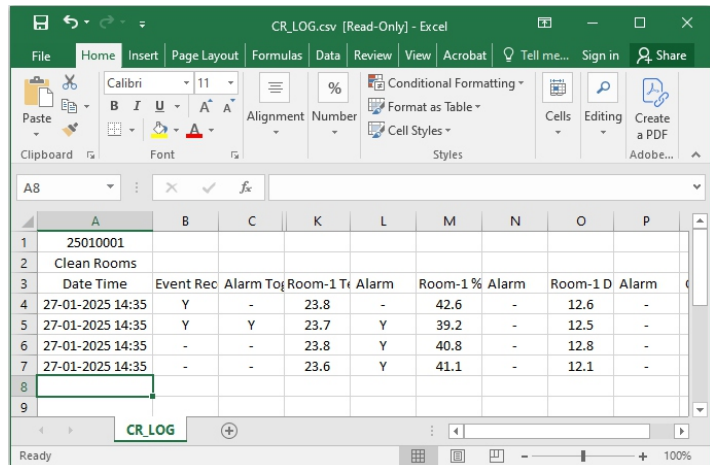
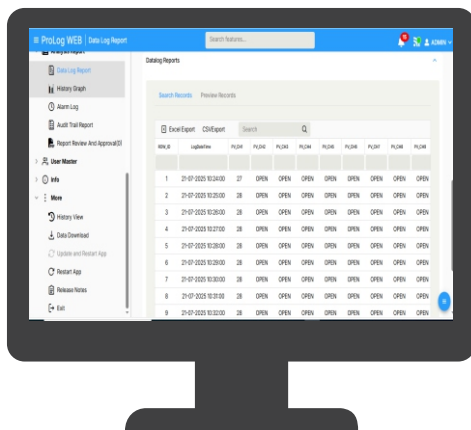

The screenshot shows an Excel spreadsheet titled 'CR_LOG.csv [Read-Only] - Excel'. The spreadsheet contains data from the ProLog WEB interface, including a table with columns for 'Date Time', 'Event Rec', 'Alarm To', and sensor readings.

	A	B	C	K	L	M	N	O	P
1	25010001								
2	Clean Rooms								
3	Date Time	Event Rec	Alarm To	Room-1 Tr	Alarm	Room-1 %	Alarm	Room-1 D	Alarm
4	27-01-2025 14:35	Y	-	23.8	-	42.6	-	12.6	-
5	27-01-2025 14:35	Y	Y	23.7	Y	39.2	-	12.5	-
6	27-01-2025 14:35	-	-	23.8	Y	40.8	-	12.8	-
7	27-01-2025 14:35	-	-	23.6	Y	41.1	-	12.1	-
8									
9									

CONTENTS

1.	FRONT PANEL : LAYOUT AND OPERATION	1
2.	BASIC OPERATION	2
3.	SET-UP MODE : ACCESS LEVEL & PARAMETER CONFIGURATION	5
4.	PEN DRIVE INTERFACE	8
5.	OPERATOR ACCESS LEVEL PARAMETERS	13
6.	SUPERVISORY ACCESS LEVEL PARAMETERS	14
7.	FACTORY ACCESS LEVEL PARAMETER	16
8.	MECHANICAL INSTALLATION	24
9.	ELECTRICAL CONNECTIONS	26
	APPENDIX-A : DC LINEAR SIGNAL INTERFACE	30
	APPENDIX-B : LOW / HIGH CLIPPING	32
	VERSION HISTORY	33

Section 1

FRONT PANEL : LAYOUT AND OPERATION

The front panel comprises of 4x20 Characters LCD Readout, tactile keys & a USB Port for Pen Drive. Refer Figure 1.1 below.

Figure 1.1

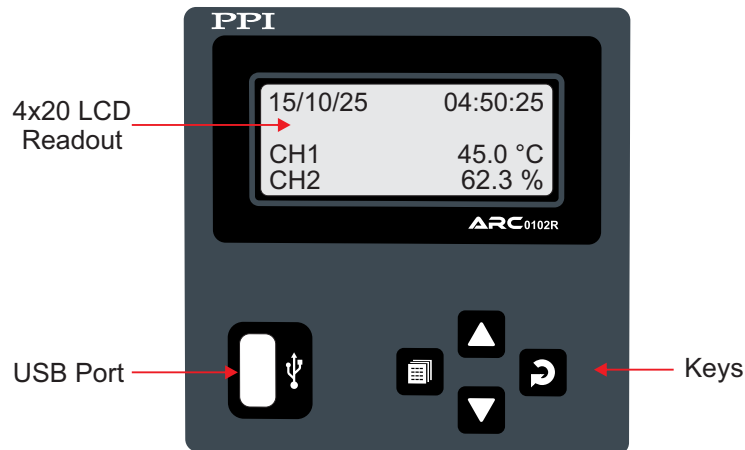

Alpha-Numeric LCD READOUT





The LCD Readout comprises 4 rows of 20 characters each. In Normal operation mode, the Readout shows various information that is divided in multiple screens. The default screen (Home Screen) shows measured Process Values for Single / Dual Channels along with user-assigned short Channel Names and the currents Date/Time.

The Enter key allows scrolling through various sub-screens that show Alarm Status for all channels, user assigned long Channel Names, Recording Information & Stored Records. The Page key allows entering set-up mode for channel configuration and parameter settings.

KEYS

There are four tactile keys provided on the front panel. The Table 1.1 below lists each key (identified by the front panel symbol) and the associated function.

Table 1.1

Symbol	Key	Function (in Set-up Mode)
	PAGE	Press to enter or exit set-up mode.
	DOWN	Press to decrease the parameter value. Pressing once decreases the value by one count; keeping pressed speeds up the change.
	UP	Press to increase the parameter value. Pressing once increases the value by one count; keeping pressed speeds up the change.
	ENTER	Press to store the set parameter value and to scroll to the next parameter.

Section 2 BASIC OPERATION

POWER-UP DISPLAY

Upon powering up, the readout displays the device information as shown below in figure 2.1.

Figure 2.1

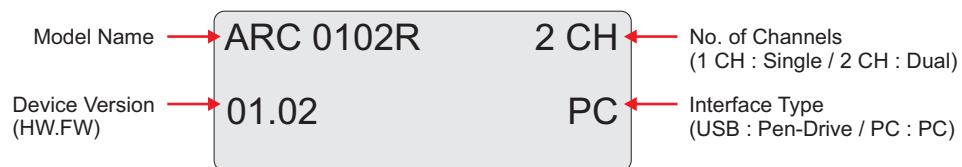

RUN MODE

After completing the power-up sequence, the device enters **RUN Mode**, its default operating state. In this mode, the device facilitates viewing process values, alarm status, and recording information through Home screen and various sub-screens.

Home Screen

Figure 2.2(a) :
Home Screen (Dual Channel)

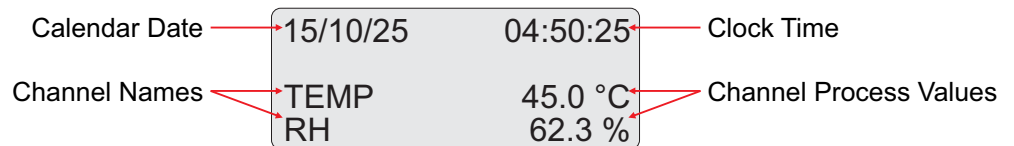
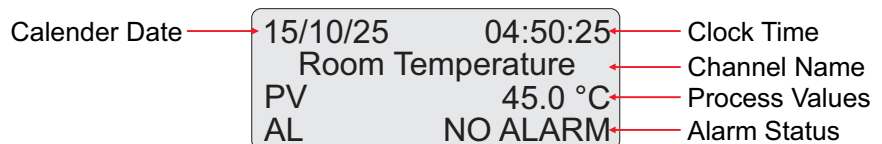

Figure 2.2(b) :
Home Screen (Single Channel)



The table below lists the process value error types and the corresponding messages that are shown in place of PV if the channel is in error condition.

Table 2.1

Message	Error Type	Cause
OPEN	Sensor Open	RTD / Thermocouple Broken / Open
OVER	Over-range	Process Value above Max. Specified Range
UNDER	Under-range	Process Value below Min. Specified Range

Alarm Info Sub-screen

1. Available for Dual Channel Only. To access this sub-screen, press Enter key from the Home screen.
2. Displays the alarm status for all 4 alarms (1 to 4) for each channel (CH 1 & CH 2).
3. The active alarms are shown with their respective numbers : A1, A2, A3, and A4 (for Alarm-1 to Alarm-4) as inverted image, white text on black background.
4. The figure 2.3 below illustrates A1 & A2 active for channel-1 named TEMP.

Figure 2.3

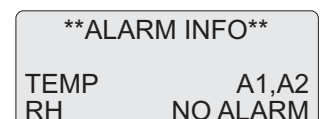

Channel Names Sub-screen

1. Available for Dual Channel Only. To access this sub-screen, press Enter key from the Alarm Info sub-screen.
2. Displays user assigned descriptive names (e.g., Room Temperature, Room Humidity) for channels (max 16 characters each). These names are visible in reports (csv files).
3. The figure 2.4 below shows example screen with channel names 'TEMP' & 'RH' for channel-1 (CH1) & channel-2 (CH2), respectively.





Figure 2.4

```
**CHANNEL NAMES**  
CH1: Room Temperature  
CH2: Room Humidity
```

Recording Information Sub-screen

1. To access this sub-screen, press Enter key from the Channel Names sub-screen.
2. The displayed sub-screen varies based on the selected interface type (USB or PC).
3. For USB interface, this sub-screen displays the following information split into two screens which can be toggled using Up/Down keys :
 - New Records : Numbers of records generated since the last upload.
 - Old Records : Previously transferred records available for reloading.
 - Total Capacity : Device's total record storage capacity.
 - Free Space : Balance space available for new records.
 - File Name : Assigned file name for record transfer.
 - Back-up File : Automatically created backup file name for recovery operation.
 - Shown below is an example screen.

Figure 2.5 (a) : For USB (Pen-Drive)

<pre>**RECORDING INFO-1** NEW RECORDS: 38 OLD RECORDS : 0 CAPACITY : 229376</pre>	 or   	<pre>**RECORDING INFO-2** FREE SPACE: 229338 FILE NAME : REC11003 BACUP FILE : B003_XXX</pre>
---	--	---

4. For PC interface displays :

- New Records
- Free Space
- Total Capacity
- Shown below is an example screen.

Figure 2.5 (b) : For PC

```
**RECORDING INFO**  
RECORDS : 310  
FREE SPACE: 229066  
CAPACITY : 229376
```

Record View Sub-screen

1. To access this sub-screen, press Enter key from the Recording Information sub-screen.
2. Displays the stored new records.
3. Scroll through records, one record at a time, using Up/Down keys.
4. Each record displays Process Value & Alarm Status for Each Channel duly date / time stamped.
5. Shown below is an example screen.

**Figure 2.6(a):
Record View (Dual Channel)**

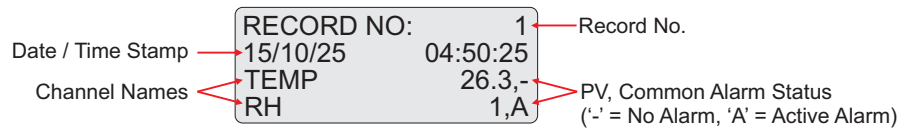

**Figure 2.6(b):
Record View (Single Channel)**

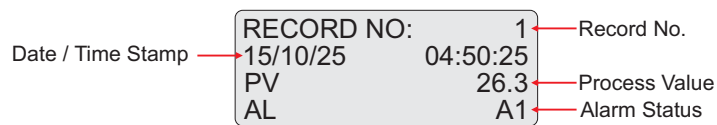

Notes :

1. If no key is pressed for 30 seconds while in a sub-screen, the device automatically reverts to the Home screen.
2. Press the Page key to manually return to the Home screen from any sub-screen.



Section 3

SET-UP MODE : ACCESS LEVELS & PARAMETER CONFIGURATION

The ARC 0102R Process Data Recorder organizes various device and channel configuration parameters into hierarchical groups, called Levels and Sub-Levels. These groupings are structured based on access permissions and functional categories. Each level and sub-level is uniquely named and represented by an icon for easy identification.

The three **Access Levels** are:

- **Operator**
- **Supervisory** (Password Protected)
- **Factory** (Password Protected)

Each access level contains multiple **Sub-Levels**, which house specific parameters. Within these sub-levels, parameters are always displayed in a fixed sequence:

- **Upper row** : Parameter name
- **Lower row** : Configurable value

All parameters appear in the exact order outlined in their respective sections of this manual.

Entering Set-Up Mode

Set-Up Mode allows users to view and modify parameter values. Follow these steps to access and configure parameters:

Step 1 : Access Set-Up Mode

Figure 3.1



From the Home Screen, press and release the Page key. The SET-UP MODE screen will appear, displaying the available access levels (Figure 3.1).

Step 2 : Selecting an Access Level

Figure 3.2

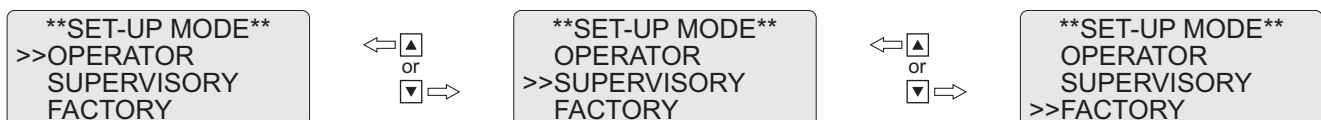

Use the Up/Down keys to navigate through the access levels. The currently selected access level is highlighted with an inverted colour scheme (white icon on a black background). Press Enter to confirm your selection.

Step 3 : Entering a Password (If Required)

Figure 3.3

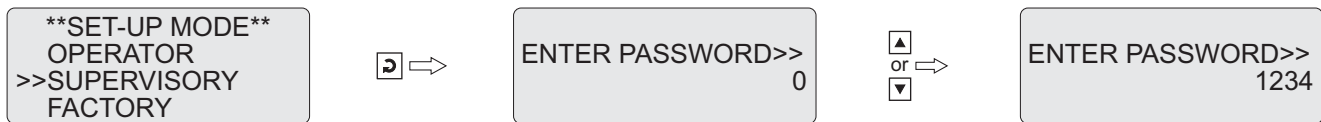

If the selected access level requires authentication, the **Enter Password** screen will appear. Use the **Up/Down** keys to enter the password (Figure 3.3). The default passwords are 1234 for Supervisory and 4321 for Factory access levels.

Press **Enter** to proceed. If the password is incorrect, the device will revert to the access level selection screen.

Step 4 : Navigating Sub-Levels

Figure 3.4

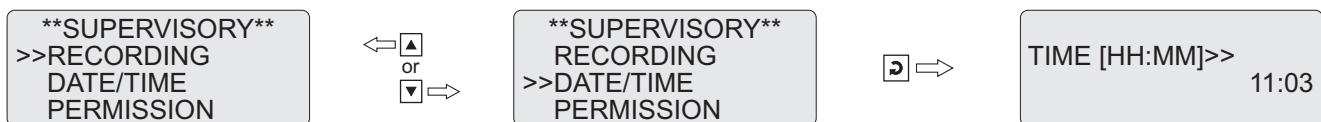

Once inside an access level, use the Up / Down keys to navigate and select a sub-level. Press Enter to access the parameters within the selected sub-level. The figure 3.4 above illustrates how to access the parameters within sub-level DATE / TIME under Supervisory access level.

Step 5 : Editing Parameters

Figure 3.5

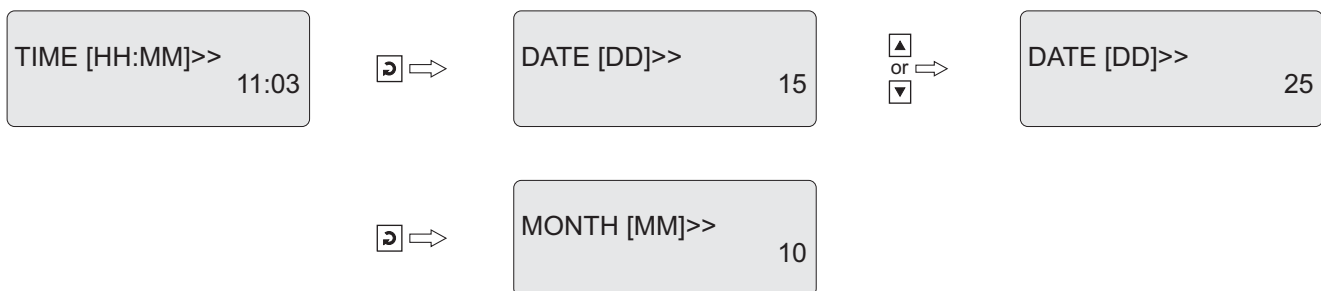

Once inside a sub-level, use Enter key to navigate through the parameters. Use the Up/Down keys to adjust the parameter value. Press Enter to save the modified value and proceed to the next parameter. The figure 3.5 above illustrates navigating to the parameters DATE (DD) within sub-level DATE / TIME under Supervisory access level and modifying its value from 15 to 25.

Summary of Access Levels, Sub-Levels, and Parameters

Below is an overview of the available sub-levels and their corresponding parameters within each access level:

Access Level	Sub-Levels	Parameters
Operator	Batch	Batch Start / Stop Balance Time
	Pen-Drive	Stop Copy File Options
Supervisory	Recording	Normal Interval, Zoom Interval, Alarm Toggle Record, Recording Mode, Batch Time, Batch Start / Stop
	Date / Time	Time (HH:MM) Date (DD) Month (MM) Year (YYYY) Unique ID
	Permission	Alarm Buzzer
	Change Password	Change Password New Password
Factory	Device	Interface Comm. ID Baud Rate Parity Factory Reset Delete Records
	Channel	Select Channel, Input Type, Resolution, Unit, Signal Low, Signal High, Range Low, Range High, Low Clip, Low Clip Value, High Clip, High Clip Value, Zero Offset, Filter (%)
	Alarm	Select Channel, Select Alarm, Alarm Type, Alarm Setpoint, Alarm Hysteresis, Alarm Inhibit
	Master Lock	Lock / Unlock
	Change Password	Change Password New Password
	Utilities	Unused. Reserved for factory use.



Section 4

PEN-DRIVE INTERFACE

The ARC 0102R Process Data Recorder allows users to perform both File Read and File Write operations using a USB Pen-Drive. These operations facilitate data management, enabling seamless transfer and organization of recorded data.

FILE READ OPERATION

The File Read operation enables users to configure specific settings for the device by uploading a text file, **Set.txt**, from the Pen-Drive. This file facilitates :

- Assign a *Location Name* for easy identification of recording equipment or location.
- Set a *File Name* for downloading records to the Pen-Drive.
- Customize *descriptive Channel Names* to label each channel in .csv record files.
- Customize short Display Names to identify each channel on recorder screens. Applicable for Dual Channel only.

Location Name

- The Location Name is included in the file header of stored records.
- Default factory setting: LOCATION.
- Users can modify this name using the File Read function.

File Name

- The device creates a default file name for record downloads.
- Users can specify a custom file name using the File Read operation.

Channel Name

- Default channel names: Channel 1, Channel 2.
- Users can assign descriptive names (e.g., Room Temperature, Room Humidity).
- These names are visible in reports (csv files).
- The channel names can be viewed in Channel Names sub-screen.

Display Name

- Applicable for Dual Channel only. Default display names: CH1, CH2.
- Users can assign short names (e.g., Temp, RH).
- These names are displayed on various screens (Home, Alarm, Record View screens).

Creating the Set.txt File

Refer figure 4.1 for an example Set.txt file followed by the guidelines to create the file.

Figure 4.1

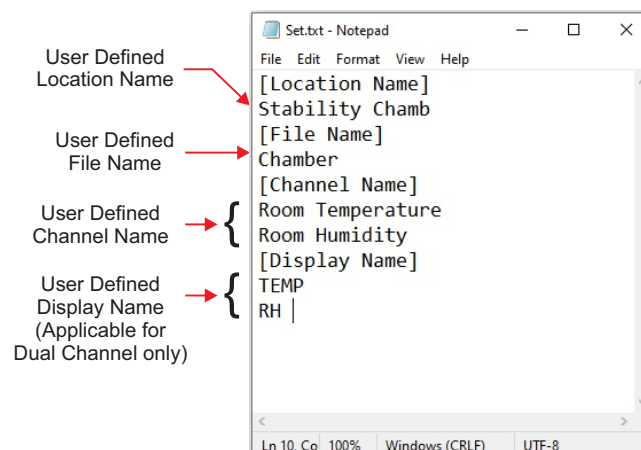

1. Use a text editor (e.g., Notepad) to create a file named Set.txt.
2. Save the file in the root directory of the Pen-Drive.
3. Formatting rules:
 - Required text within square brackets before user-defined names.
 - Square bracket text is case-insensitive.
 - No blank lines.
 - Location Name: Max 16 characters.
 - File Name: Max 8 characters (stored in uppercase). The device automatically adds the extension .csv.
 - Channel Name: Max 16 characters.
 - Display Name: Max 6 characters. (Applicable for Dual Channel only).

FILE WRITE OPERATION

The File Write operation allows users to copy stored records from the device's internal memory to a Pen-Drive in CSV format.

Key Features

- Records consist of process values and alarm statuses, time-stamped with date and time.
- Data is stored at user-defined intervals (Recording Interval).
- Records can be downloaded via the front-panel USB port.

File Naming Convention

- The device uses either a user-defined file name or a default naming scheme.
- Default naming scheme : RECnnnnn.csv, where nnnnn is a unique 5-digit code from the device's 8-digit Unique ID.
- Example : If Unique ID is 25010001, the file name will be REC10001.csv.
- The 8-digit Unique ID can be viewed in the sub-level "DATE / TIME" under Supervisory access level.
- The user-defined file name overrides the default.
- The File Name is stored in the device non-volatile memory and is available for view in Recording Information sub-screen.

File Write Scenarios

Case 1: File Does Not Exist

- The device creates a new file with the name stored in the device's internal memory.
- Records are downloaded in CSV format with File Header. Refer figure 4.2.

Figure 4.2

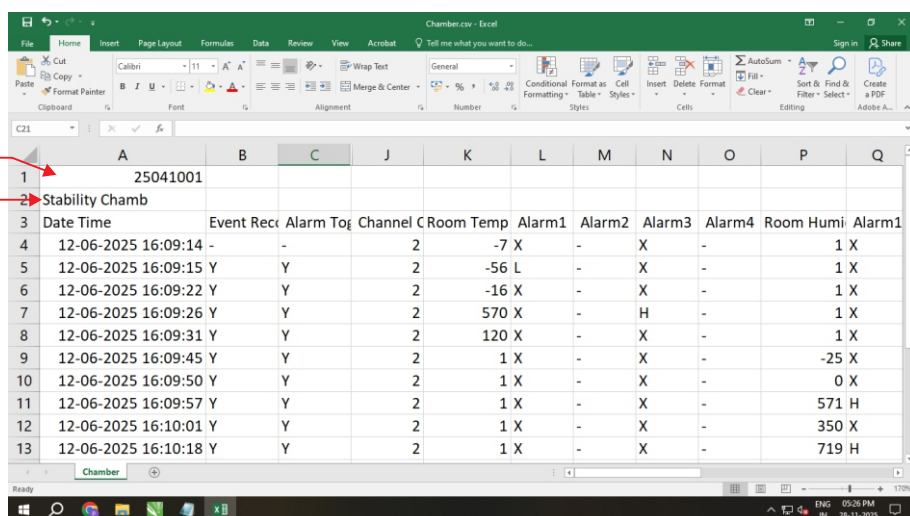

File Header

- 1 25041001 (8 digit UNIQUE ID)
- 2 Stability Chamb (Location Name)

Records

3	Date Time	Event Recd	Alarm Top	Channel C	Room Temp	Alarm1	Alarm2	Alarm3	Alarm4	Room Humi	Alarm1
4	12-06-2025 16:09:14	-	-	2	-7	X	-	X	-		1 X
5	12-06-2025 16:09:15	Y	Y	2	-56	L	-	X	-		1 X
6	12-06-2025 16:09:22	Y	Y	2	-16	X	-	X	-		1 X
7	12-06-2025 16:09:26	Y	Y	2	570	X	-	H	-		1 X
8	12-06-2025 16:09:31	Y	Y	2	120	X	-	X	-		1 X
9	12-06-2025 16:09:45	Y	Y	2	1	X	-	X	-		-25 X
10	12-06-2025 16:09:50	Y	Y	2	1	X	-	X	-		0 X
11	12-06-2025 16:09:57	Y	Y	2	1	X	-	X	-		571 H
12	12-06-2025 16:10:01	Y	Y	2	1	X	-	X	-		350 X
13	12-06-2025 16:10:18	Y	Y	2	1	X	-	X	-		719 H

Alarm Status : 'X' = No Alarm, 'H' = High Alarm, 'L' = Low Alarm, '-' = Alarm Not Configured
Other fields : 'Y' = Yes, '-' = No

Case 2: File Exists

- If a file with the name matching with the stored file name exists on the Pen-Drive :
 - The device reads the File Header.
 - If the 8 digit Unique ID in the File Header matches, records are appended.
 - If not, the following error is displayed.
Could not Append
Device Differs

Back-up File System

The ARC 0102R Process Data Recorder is equipped with a robust back-up file system to safeguard against data loss during interrupted file-write operations, such as sudden power failures or accidental Pen-Drive removal. The file back-up operation works as below.

1. Automatic Detection of Interrupted Operations:

- The device continuously monitors file-write operations.
- It is possible that a file-write operation may be interrupted due to reasons like sudden power-failure or removal (or, loose-contact) of the Pen-Drive, resulting in a partial transfer of records. An interrupted file-write operation makes the file unusable for appending any further records. Also, the partially transferred records in the interrupted file are lost (but are still retained inside the device internal memory). That is, the file on Pen-Drive exists with the previous records intact (if any) and becomes a read-only file.

2. Backup File Creation:

- Upon resuming operation, the device prompts the user to initiate the Recover process.
- A back-up file of the interrupted file is created to retain the previous records.
- The backup file is named using the format BXXX_S.csv, where:

XXX is the last 3 digits of the 5-digit Unique ID.

S is a sequential number (1-250) assigned to the backup file.

- Example: If the Unique ID is 10001 and no previous backups exist, the backup file will be B001_1.csv. If backups already exist (e.g., B001_1.csv, B001_2.csv), the next sequential number is used (e.g., B001_3.csv).

3. Recovery Process:

- The interrupted file (after creating back-up) is deleted.
- A new file with the same name is created.
- All records, including those partially transferred during the interruption, are written to the new file.

PEN-DRIVE OPERATION & OPTIONS

The device is provided with a front panel USB port for file read and write operations using Pen-Drive.

Pen-Drive Checking

1. Upon inserting the Pen-Drive, the message "Please Wait..." appears while the device checks the drive.
2. If the pen-drive falls or does not respond within 60 seconds, the message "Device Failure" is displayed.
3. Remove & re-insert the drive and press Enter for rechecking.
4. If the problem persists, remove the drive. the display shows "Insert Drive". Press Enter key to revert to Home screen.
5. Check pen-drive format or try using another pen-drive. If nothing works, report the issue to the factory.

Download Records

If the pen-drive checking operation is successful, the device presents, in sequence, one or more of the options shown in the table below for the next operation. Use Up/Down keys to select the desired option and then press Enter key to execute the selected operation.

Option	Operation
None	Exit to the Home screen.
Copy (New)	Copies new, un-transferred records. This option is available only if there are new records to copy.
Re-copy (Old)	Re-copies previously transferred records. This option is available only if there are old records to re-copy.
Read Set.txt File	Reads the configuration file (Set.txt). This option is available only if the drive contains the file Set.txt.
Recover	Recovers from interrupted file-write operations. This option is available only if the previous file write operation was interrupted.

Download Operation

Upon selecting the Copy, Re-copy or Recover option, the device begins downloading the records with the below message.

Copying...
Bal 1234

The upper row shows the operation type; Copying for 'Copy' operation or Re-copying for 'Re-copy' or 'Recover' operation. The Lower Row displays countdown of the numbers of balance records.

Upon successful completion of the operation, the device displays the total numbers of records copied (or, re-copied) through the message shown below.

Records Copied..
1234

Remove the Pen-Drive and acknowledge the message using Enter key. The device reverts to Home screen.

'Read Set.txt File' Operation

Upon selecting 'Read Set.txt File' operation, the device opens the file named *Set.txt* for reading the user defined Location Name, File Name & Channel Name (refer section "File Read Operation"). After successful reading the device shows the below message.

Names Assigned

Remove the Pen-Drive and acknowledge the message using Enter key. The device reverts to Home screen.

File Read / Write Errors & Troubleshooting

The table below list common error messages and their meanings :

Table : 4.1

Error Message	Operation	What it Means
Cant Open File	Copy (New) Re-copy (Old) Recover	Unable to open an existing file or create a new file.
Cant Write File Bal 1234	Copy (New) Re-copy (Old) Recover	Unable to write records in an Open file.
Disc Full Bal 1234	Copy (New) Re-copy (Old) Recover	No space on Pen-Drive to continue writing records in an Open file.
Cant Close File	Copy (New) Re-copy (Old) Recover	Unable to close the file after successful read / write operation.
Cant Rename File	Recover	Unable to rename an interrupted file for back-up
Cant Delete File	Recover	Unable to delete an interrupted file.
Cant Sync USB	Any	USB port failure.
Cant Change Baud	Any	USB communication issue.

In case of any of the above Error Messages, make sure that the Pen-Drive is firmly inserted in the USB port and retry the operation by acknowledging the error message through front panel ENTER key. If the error persists, replace the Pen-Drive. In case of USB port failure send device to the authorized seller for servicing.



Section 5

OPERATOR ACCESS LEVEL PARAMETERS

The Table 5.1 below described the parameters grouped in various sub-levels under Operator access level.

Table 5.1

OPERATOR > BATCH	
Parameter Description	Settings
BATCH START <ul style="list-style-type: none"> Available for Batch Mode Recording only. Presented at the beginning of a batch. Select Yes to start batch recording. 	No Yes
BALANCE TIME <ul style="list-style-type: none"> Read only parameter. Shows the remaining batch time while the batch is running. 	Read Only
BATCH STOP <ul style="list-style-type: none"> Available for Batch Mode Recording only. Presented while the batch is running. Select Yes to manually stop / abort the running batch. 	No Yes
OPERATOR > PEN-DRIVE	
Parameter Description	Settings (Default Value)
STOP COPY <ul style="list-style-type: none"> Available for USB Interface type only. Presented while the records are transferring to the pen-drive. Select Yes to manually abort record transfer. 	No Yes
FILE OPTIONS <ul style="list-style-type: none"> Available for USB Interface type only. This parameter is also available on the Home screen when a pen-drive insertion is detected. Refer section 4 : PEN-DRIVE INTERFACE for detailed option list. 	None Copy (New) Re-copy (Old) Read Set.txt File Recover (Default : None)



Section 6

SUPERVISORY ACCESS LEVEL PARAMETERS

The Table 6.1 below described the parameters grouped in various sub-levels under Supervisory access level.

Table 6.1

SUPERVISORY > RECORDING	
Parameter Description	Settings (Default Value)
<p>NORMAL INTERVAL>></p> <ul style="list-style-type: none"> Periodic recording interval in HH:MM:SS format. Set to 0:00:00 to disable periodic recording. 	0:00:00 (H:MM:SS) to 2:30:00 (H:MM:SS) (Default : 0:00:30)
<p>ZOOM INTERVAL>></p> <ul style="list-style-type: none"> Zoom recording interval in HH:MM:SS format. Overrides periodic interval when any of the channels is in alarm state. Set to 0:00:00 to disable zoom recording. 	0:00:00 (H:MM:SS) to 2:30:00 (H:MM:SS) (Default : 0:00:10)
<p>ALARM TOGGL RECORD>></p> <ul style="list-style-type: none"> If enabled, a record is generated each time an alarm changes its state from off-to-on or on-to-off. Disabling this parameter turns off record generation on alarm status change. 	Disable Enable (Default : Enable)
<p>RECORDING MODE>></p> <p><i>Continuous Mode</i></p> <ul style="list-style-type: none"> The records are generated uninterrupted. Suitable for continuous (non time-bound) processes. <p><i>Batch Mode</i></p> <ul style="list-style-type: none"> Records are generated over a preset time interval (batch time). Recording begins with manual start command and stops after the batch time is elapsed. Suitable for batch processes. 	Continuous Batch (Default : Continuous)
<p>BATCH TIME>></p> <ul style="list-style-type: none"> Available for batch mode recording. Defines batch recording time in HH:MM format. 	0:01 (HH:MM) to 250:00 (HHH:MM) (Default : 1:00)
<p>BATCH START>> BATCH STOP>></p> <ul style="list-style-type: none"> Mutually exclusive batch commands. Use start command to commence batch recording. Use stop command to manually abort the batch recording in progress. These commands are also available on operator level parameters. 	No Yes

SUPERVISORY > DATE / TIME	
Parameter Description	Settings
TIME [HH:MM]>> <ul style="list-style-type: none"> Clock time in 24 hours format. 	0:0 to 23:59
DATE [DD]>> <ul style="list-style-type: none"> Calendar date. 	1 to 31
MONTH [MM]>> <ul style="list-style-type: none"> Calendar month. 	1 to 12
YEAR [YYYY]>> <ul style="list-style-type: none"> Calendar year. 	2000 to 2099
UNIQUE ID>> <ul style="list-style-type: none"> 8 digit factory set unique device id. Used for USB interface type to generate default file names. Read-only parameter (non-editable). Refer section 4 : PEN-DRIVE INTERFACE. 	Read Only
SUPERVISORY > PERMISSION	
Parameter Description	Settings (Default Value)
ALARM BUZZER>> <ul style="list-style-type: none"> Enables / disables buzzer beeping on alarm activation. 	Disable Enable (Default : Enable)
SUPERVISORY > CHANGE PASSWORD	
Parameter Description	Settings (Default Value)
CHANGE PASSWORD>> <ul style="list-style-type: none"> Allows changing the Supervisory Access Level password. Set to yes for changing the password. Factory default is 1234. 	No Yes (Default : No)
NEW PASSWORD>> <ul style="list-style-type: none"> Set new 4 digit numeric password for Supervisory Access Level access. 	0 to 9999



Section 7

FACTORY ACCESS LEVEL PARAMETERS

The Table 7.1 below described the parameters grouped in various sub-levels under Factory access level.

Table 7.1

FACTORY > DEVICE	
Parameter Description	Settings (Default Value)
INTERFACE>> <ul style="list-style-type: none"> Interface type for record uploading. Select PC for uploading through RS485 serial port. Select USB for record transfer to a pen-drive via USB port. The Online Data is still available through PC port. 	PC USB
COMMUNICATION ID>> <ul style="list-style-type: none"> Slave ID for RS485 serial port. 	1 to 127 (Default : 1)
BAUD RATE >> <ul style="list-style-type: none"> Available if selected interface type is USB. Communication speed in 'Bits per Second'. For PC interface type, the baud rate is fixed to 9600. 	2400, 4800, 9600 14400, 19200 (Default : 9600)
PARITY >> <ul style="list-style-type: none"> Available if selected interface type is USB. Communication error trapping feature. For PC interface type, the parity is fixed to 'Even'. 	None Even Odd (Default : Even)
FACTORY RESET>> <ul style="list-style-type: none"> Resets all parameters to factory default settings. The device restarts after issuing this command. 	No Yes (Default : No)
DELETE RECORDS>> <ul style="list-style-type: none"> Clears the internal storage memory. Deletes all stored records (both old & new). 	No Yes (Default : No)
FACTORY > CHANNEL	
Parameter Description	Settings (Default Value)
SELECT CHANNEL>> <ul style="list-style-type: none"> Available for Dual Channel only. Allows selection of channel (1 or 2) for parameter settings. 	1 or 2

Parameter Description	Settings (Default Value)																											
<p>INPUT TYPE>></p> <ul style="list-style-type: none"> Defines the type of input signal the selected channel will process. Sensor Inputs : Thermocouples & RTDs. Transmitter Signal : mV / V / mA. 	<p>Refer Table 7.2 (Default : 0 to 10 V)</p>																											
<p>RESOLUTION>></p> <ul style="list-style-type: none"> Determines the decimal point position for the measured PV. Parameters such as alarm limits, hysteresis, etc. follow the set resolution setting. 	<p>Refer Table 7.2</p>																											
<p>UNIT>></p> <ul style="list-style-type: none"> Select the Units that shall be displayed along with the measured PV on the display. For temperature input (Thermocouple & RTD), only °C and °F units are available and represent actual converted values. All other units available for DC Linear signal input are for indication purpose only and should be selected as per the units specified by the transmitter. 	<p>Refer Table 7.3</p>																											
<p>SIGNAL LOW>></p> <ul style="list-style-type: none"> Applicable to mV / V / mA input signals. Helps in scaling transmitter signals to match the desired display range. Defines the input signal value corresponding to the low end of the displayed process range. Refer <i>Appendix-A : DC Linear Signal Interface</i> for details. 	<table border="1"> <thead> <tr> <th>Input Type</th> <th>Settings</th> <th>Default</th> </tr> </thead> <tbody> <tr> <td>0 to 20 mA</td> <td>0.00 to Signal High</td> <td>0.00</td> </tr> <tr> <td>4 to 20 mA</td> <td>4.00 to Signal High</td> <td>4.00</td> </tr> <tr> <td>0 to 80 mV</td> <td>0.00 to Signal High</td> <td>0.00</td> </tr> <tr> <td>0 to 1.25 V</td> <td>0.000 to Signal High</td> <td>0.000</td> </tr> <tr> <td>0 to 5 V</td> <td>0.000 to Signal High</td> <td>0.000</td> </tr> <tr> <td>0 to 10 V</td> <td>0.00 to Signal High</td> <td>0.00</td> </tr> <tr> <td>1 to 5 V</td> <td>1.000 to Signal High</td> <td>1.000</td> </tr> <tr> <td>0 to 160 mV</td> <td>0.000 to Signal High</td> <td>0.000</td> </tr> </tbody> </table>	Input Type	Settings	Default	0 to 20 mA	0.00 to Signal High	0.00	4 to 20 mA	4.00 to Signal High	4.00	0 to 80 mV	0.00 to Signal High	0.00	0 to 1.25 V	0.000 to Signal High	0.000	0 to 5 V	0.000 to Signal High	0.000	0 to 10 V	0.00 to Signal High	0.00	1 to 5 V	1.000 to Signal High	1.000	0 to 160 mV	0.000 to Signal High	0.000
Input Type	Settings	Default																										
0 to 20 mA	0.00 to Signal High	0.00																										
4 to 20 mA	4.00 to Signal High	4.00																										
0 to 80 mV	0.00 to Signal High	0.00																										
0 to 1.25 V	0.000 to Signal High	0.000																										
0 to 5 V	0.000 to Signal High	0.000																										
0 to 10 V	0.00 to Signal High	0.00																										
1 to 5 V	1.000 to Signal High	1.000																										
0 to 160 mV	0.000 to Signal High	0.000																										
<p>SIGNAL HIGH>></p> <ul style="list-style-type: none"> Applicable to mV / V / mA input signals. Helps in scaling transmitter signals to match the desired display range. Defines the input signal value corresponding to the high end of the displayed process range. Refer <i>Appendix-A : DC Linear Signal Interface</i> for details. 	<table border="1"> <thead> <tr> <th>Input Type</th> <th>Settings</th> <th>Default</th> </tr> </thead> <tbody> <tr> <td>0 to 20 mA</td> <td>Signal Low to 20.00</td> <td>20.00</td> </tr> <tr> <td>4 to 20 mA</td> <td>Signal Low to 20.00</td> <td>20.00</td> </tr> <tr> <td>0 to 80 mV</td> <td>Signal Low to 80.00</td> <td>80.00</td> </tr> <tr> <td>0 to 1.25 V</td> <td>Signal Low to 1.250</td> <td>1.250</td> </tr> <tr> <td>0 to 5 V</td> <td>Signal Low to 5.000</td> <td>5.000</td> </tr> <tr> <td>0 to 10 V</td> <td>Signal Low to 10.00</td> <td>10.00</td> </tr> <tr> <td>1 to 5 V</td> <td>Signal Low to 5.000</td> <td>5.000</td> </tr> <tr> <td>0 to 160 mV</td> <td>Signal Low to 160.0</td> <td>160.0</td> </tr> </tbody> </table>	Input Type	Settings	Default	0 to 20 mA	Signal Low to 20.00	20.00	4 to 20 mA	Signal Low to 20.00	20.00	0 to 80 mV	Signal Low to 80.00	80.00	0 to 1.25 V	Signal Low to 1.250	1.250	0 to 5 V	Signal Low to 5.000	5.000	0 to 10 V	Signal Low to 10.00	10.00	1 to 5 V	Signal Low to 5.000	5.000	0 to 160 mV	Signal Low to 160.0	160.0
Input Type	Settings	Default																										
0 to 20 mA	Signal Low to 20.00	20.00																										
4 to 20 mA	Signal Low to 20.00	20.00																										
0 to 80 mV	Signal Low to 80.00	80.00																										
0 to 1.25 V	Signal Low to 1.250	1.250																										
0 to 5 V	Signal Low to 5.000	5.000																										
0 to 10 V	Signal Low to 10.00	10.00																										
1 to 5 V	Signal Low to 5.000	5.000																										
0 to 160 mV	Signal Low to 160.0	160.0																										
<p>RANGE LOW>></p> <ul style="list-style-type: none"> Applicable to mV / V / mA input signals. Helps in signal-to-value mapping for transmitter signal inputs. Defines the displayed process value that corresponds to the Signal Low input. Refer <i>Appendix-A : DC Linear Signal Interface</i> for details. 	<p>-30000 to +30000 (Default : 0)</p>																											

Parameter Description	Settings (Default Value)
<p>RANGE HIGH>></p> <ul style="list-style-type: none"> • Applicable to mV / V / mA input signals. • Helps in signal-to-value mapping for transmitter signal inputs. • Defines the displayed process value that corresponds to the Signal High input. • Refer <i>Appendix-A: DC Linear Signal Interface</i> for details. 	<p>-30000 to +30000 (Default : 1000)</p>
<p>LOW CLIPPING>></p> <ul style="list-style-type: none"> • Applicable for mV / V / mA inputs. • Refer Appendix-B. 	<p>Disable Enable (Default : Disable)</p>
<p>LOW CLIP VALUE>></p> <ul style="list-style-type: none"> • Applicable for mV / V / mA inputs. • Refer Appendix-B. 	<p>-30000 to HIGH CLIP VAL (Default : 0)</p>
<p>HIGH CLIPPING>></p> <ul style="list-style-type: none"> • Applicable for mV / V / mA inputs. • Refer Appendix-B. 	<p>Disable Enable (Default : Disable)</p>
<p>HIGH CLIP VALUE>></p> <ul style="list-style-type: none"> • Applicable for mV / V / mA inputs. • Refer Appendix-B. 	<p>LOW CLIP VAL to 30000 (Default : 1000)</p>
<p>ZERO OFFSET>></p> <ul style="list-style-type: none"> • Compensates for sensor zero-offset or thermal gradient errors. • The set value is algebraically added to the measured Process Value (PV) to correct deviations. • Final PV = Measured PV + Zero-offset. 	<p>-30000 to +30000 (Default : 0)</p>
<p>FILTER (%)>></p> <ul style="list-style-type: none"> • Applies an IIR (Infinite Impulse Response) filter to the measured Process Value (PV) to minimize signal noise and fluctuations. • Adjustable filter strength from 0% to 90%. • Setting 0% disables the filter. • Higher values provide greater noise reduction but result in a slower response time. • Lower values allow faster response but with less noise suppression. 	<p>0 to 90% (Default : 20%)</p>

Table 7.2

Input Type	Range (Min. to Max.)	Resolution
Type J	0.0 to +960.0°C	1 °C or 0.1 °C
Type K	-200.0 to +1376.0°C	
Type T	-200.0 to +387.0°C	
Type R	0.0 to +1771.0°C	
Type S	0.0 to +1768.0°C	
Type B	0.0 to +1826.0°C	
Type N	0.0 to +1314.0°C	
Type E	-200.0 to +1000.0°C	
RTD Pt100	-199.9 to +850.0°C	
RTD Pt1000		
0 to 20 mA	-30000 to 30000 units	
4 to 20 mA		
0 to 80 mV		
0 to 160 mV		
0 to 1.25 V		
0 to 5.0 V		
0 to 10.0 V		
1 to 5.0 V		

Table 7.3

Option	Description
°C	Degree Centigrade
°F	Degree Fahrenheit
(none)	No Unit (Blank)
°K	Degree Kelvin
EU	Engineering Units
%	Percentage
Pa	Pascals
Mpa	Mpascals
kPa	Kpascals
bar	Bar
mbar	Milli bar
psi	PSI
KGCM	kg/cm ²
mmH ₂ O	mm water gauge
inH ₂ O	Inches water gauge
mmHg	mm mercury
Torr	Torr
LPH	Litres per hour
LPM	Litres per minute
%RH	% Relative Humidity
%O ²	% Oxygen
%CO ²	% Carbon di-oxide
%CP	% Carbon Potential
V	Volts
A	Amps

Option	Description
mA	Milli Amps
mV	Milli Volts
ohm	Ohms
ppm	Parts per million
rpm	Revolutions per minute
mSec	Milli seconds
Sec	Seconds
min	Minutes
hrs	Hours
PH	PH
%PH	%PH
MPH	Miles per hour
mg	Milli grams
g	Grams
kg	Kilo grams

FACTORY > ALARM	
Parameter Description	Settings (Default Value)
SEL CHANNEL (Select Channel) <ul style="list-style-type: none"> Allows selection of a specific channel (1 or 2) for configuring alarm settings. 	1 or 2
SEL ALARM (Select Alarm Number) <ul style="list-style-type: none"> Allows selection of alarm number (AL1 to AL4) for the selected channel. 	AL1 AL2 AL3 AL4
ALn TYPE (n = 1, 2, 3, 4) <ul style="list-style-type: none"> Defines the alarm condition for the selected alarm number. <i>None</i> <ul style="list-style-type: none"> Disables the alarm. <i>Process Low</i> <ul style="list-style-type: none"> Triggers an alarm when PV drops below the set low limit. <i>Process High</i> <ul style="list-style-type: none"> Triggers an alarm when PV exceeds the set high limit. 	None Process Low Process High (Default : None)
ALn SETPOINT (n = 1, 2, 3, 4) <ul style="list-style-type: none"> Defines the alarm limit for the selected alarm number. Sets the low limit if the alarm type is Process Low. Sets the high limit if the alarm type is Process High. 	Min. to Max. of selected input type range (Default : 0)
ALn HYST (Alarm Hysteresis, n = 1, 2, 3, 4) <ul style="list-style-type: none"> Specifies the hysteresis value for the selected alarm. Introduces a dead band between the ON and OFF states to prevent rapid switching. 	1 to 30000 (Default : 20)
ALn INHIBIT (n = 1, 2, 3, 4) <ul style="list-style-type: none"> Decides whether alarm monitoring starts immediately after power-up. <i>Yes</i> <ul style="list-style-type: none"> Alarm monitoring begins only after the PV crosses the limit once: <ul style="list-style-type: none"> Above the low limit for Process Low alarms. Below the high limit for Process High alarms. <i>No</i> <ul style="list-style-type: none"> The alarm monitors PV immediately after power-up. 	No Yes (Default : No)

FACTORY > MASTER LOCK	
Parameter Description	Settings (Default Value)
<p>LOCK UNLOCK</p> <ul style="list-style-type: none"> Lock and Unlock are mutually exclusive; only one setting can be active at a time. <p><i>Lock</i></p> <ul style="list-style-type: none"> Restricts modification of parameter settings to prevent accidental changes. Once locked, parameter values cannot be edited by the operator. <p><i>Unlock</i></p> <ul style="list-style-type: none"> Allows editing and modification of parameter settings. 	<p>No Yes (Default : No)</p>
FACTORY > CHANGE PASSWORD	
Parameter Description	Settings (Default Value)
<p>CHANGE PSW (Change Password)</p> <ul style="list-style-type: none"> Allows changing the Factory Access Level password. Set to yes for changing the password. Factory default is 4321. 	<p>No Yes (Default : No)</p>
<p>NEW PASSWORD</p> <ul style="list-style-type: none"> Set new 4 digit numeric password for Factory Access Level access. 	<p>0 to 9999</p>
FACTORY > UTILITIES	
Parameter Description	Settings (Default Value)
<p>ENTER CODE</p> <ul style="list-style-type: none"> Unused. Reserved for factory use. 	<p>NA</p>



Section 8 MECHANICAL INSTALLATION

Installation Precautions

Ensure the following precautions are taken while installing the device:

1. *Environment*

Install in a location free from corrosive/combustible gases and electrically conductive pollutants.

2. *Temperature & Humidity*

Avoid rapid temperature changes that may cause condensation. Ensure ambient conditions do not exceed the specified temperature and humidity limits.

3. *Electromagnetic Interference (EMI)*

Protect the installation site from excessive electrostatic or electromagnetic interference.

4. *Vibration & Shock*

Do not mount the device in areas with high vibration or mechanical shock.

5. *External Elements*

Keep the device away from dust, salt air, direct sunlight, and radiant heat sources.

Outer Dimensions

Refer to Figure 8.1 for the outer dimensions of the device.

Figure 8.1

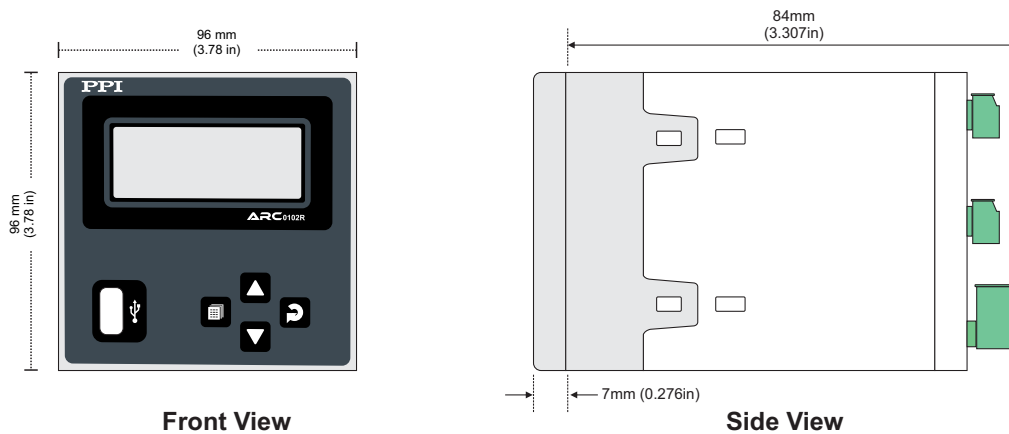

Panel Cutout & Spacing Requirements

- **Cutout Size**
[92 × 92, mm, -0, +0.5 mm]
[3.622" × 3.622", -0, +0.02"]
- **Minimum Spacing**
Maintain the recommended clearance if installing multiple devices on the same panel.
- **Reference**
See Figure 8.2 for panel cutout dimensions and spacing guidelines.

Figure 8.2

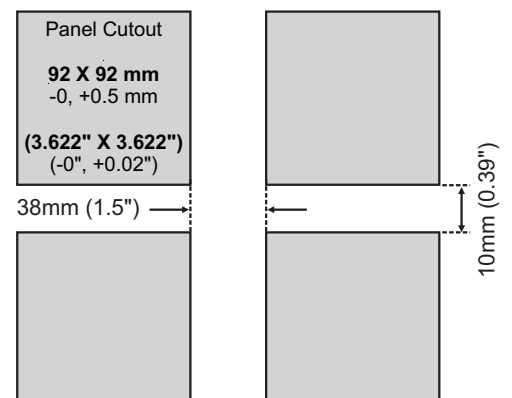

Panel Mounting Instructions

Figure 8.3

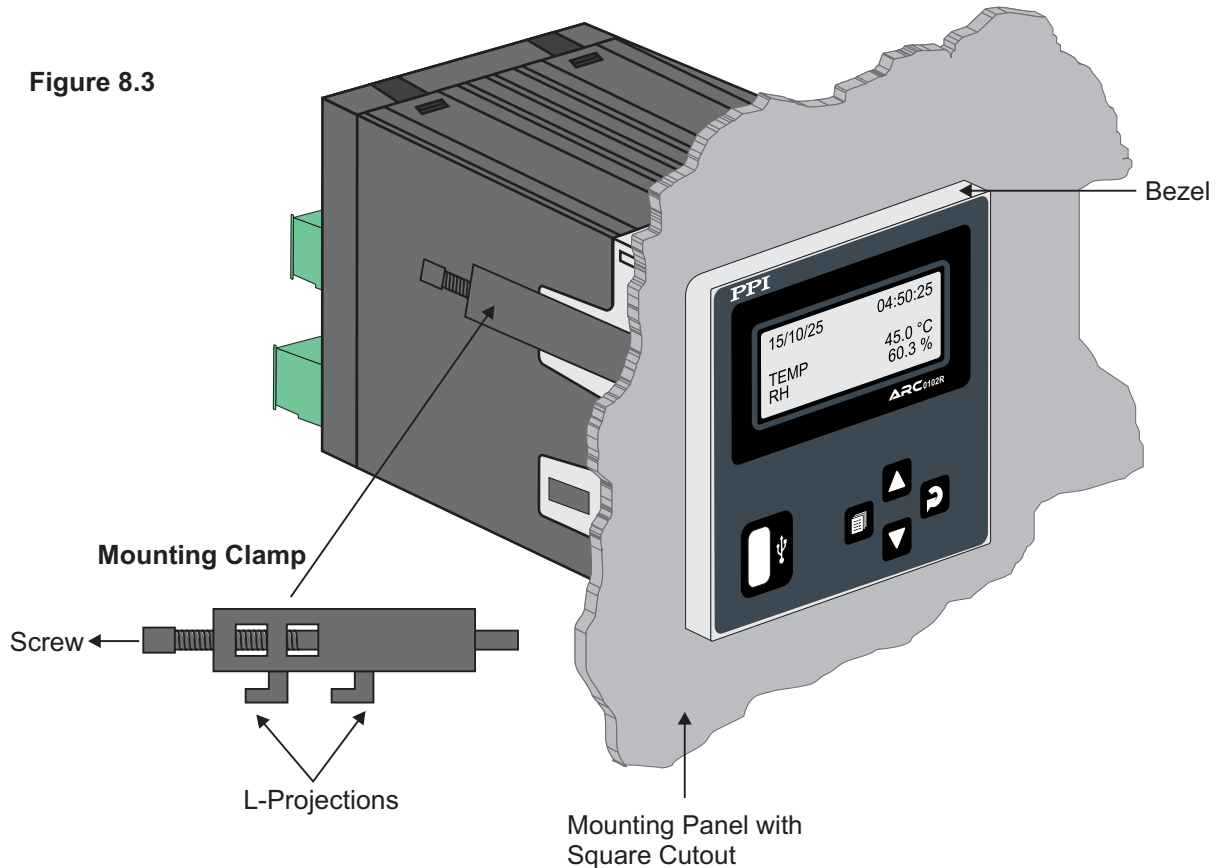

Follow these steps to securely mount the device on a panel:

1. Prepare the Cutout
Create a square cutout on the panel according to the dimensions in Figure 8.2.
2. Remove Mounting Clamps
Detach the Mounting Clamps from the device enclosure.
3. Insert the device:
 - From the front of the panel, insert the rear side of the device housing through the cutout.
 - Ensure the device sits squarely against the panel wall.
 - Caution: Apply pressure only on the bezel, not on the front label.
4. Secure with Mounting Clamps:
 - Attach each clamp so that its L-projections fit into the holes on the left and right sides of the enclosure.
 - Tighten the screws until the clamps firmly secure the device against the panel wall.
5. Reference
 - See Figure 8.3 for panel mounting.



Input Channel Connections

Each of the two input channels follows an identical wiring configuration. For clarity in wiring description, the four terminals associated with each channel are labeled T1, T2, T3 & T4.

Thermocouple (TC) Connections

- Connect the Thermocouple Positive (+) to T2 and Negative (-) to T3.
- Use the correct type of extension wires or compensating cables, ensuring polarity consistency.
- Avoid splicing or joining cables to prevent signal degradation.

Figure 9.2(a)

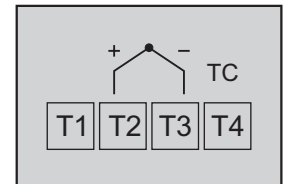

RTD (Pt100 / Pt1000, 3-Wire) Connections

- Connect the single leaded end of the RTD sensor to T2.
- Connect the double leaded ends to T3 and T4 (interchangeable).
- Use copper conductors of low resistance, ensuring that all three leads are of the same gauge and length.

Figure 9.2(b)

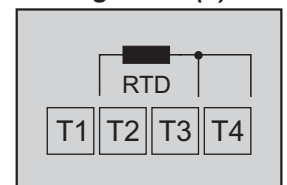

DC Voltage (V / mV) Input

- Use shielded twisted-pair cables, with the shield grounded at the signal source.
- Connect common (-) to T3 and signal (+) to T2.

Figure 9.2(c)

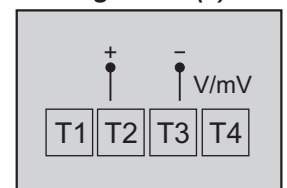

DC Current (mA) Input

- Use shielded twisted-pair cables, with the shield grounded at the signal source.
- Connect common (-) to T3 and signal (+) to T2. Short T1 & T2.

Figure 9.2(d)

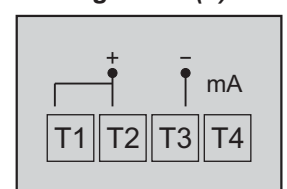

Alarm Relay Outputs (AL-1 / AL-3 & AL-2 / AL-4)

- For clarity in wiring description, the two terminals associated with each alarm relay output are labeled T5 & T6.
- Relay outputs provide potential-free changeover contacts:
 - Normally Open (NO) and Common (C) rated at 2A/240V AC (resistive load).
- For high-power loads, use an external contactor with an appropriate rating.

Figure 9.3

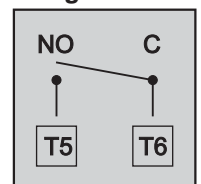

Transmitter Excitation Voltage For Channel-1 (Terminal 8) & Channel-2 (Terminal 13)

- The Excitation Voltage for powering external transmitters are provided on terminals 8 & 13 for Channel-1 & Channel-2, respectively.
- The device provides a 5V, 12V or 24V DC power source @ 30 mA for exciting current / voltage output transmitters. The default is 24 VDC.
- Wiring for different transmitter types are illustrated in below figures. The 1 to 3.6V output is only for example, the actual output could be any other values like 0 to 5V, 0 to 10V, etc.

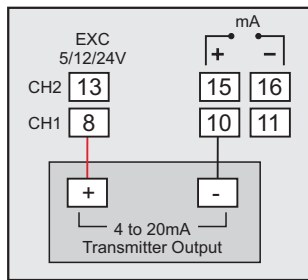

2-wire Current Transmitter
(5/12/24VDC Supply)

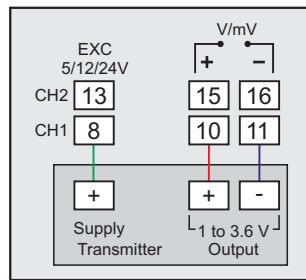

3-wire Voltage Transmitter
(5/12/24VDC Supply)

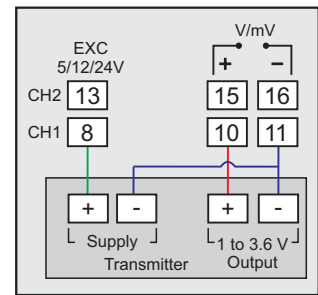

4-wire Voltage Transmitter
(5/12/24VDC Supply)

Digital Input For Batch Start Command

- Connect a potential-free contact switch to trigger batch recording.
- A transition from OPEN to CLOSE initiates time-based batch recording.
- Once recording begins, subsequent switch transitions have no effect.

Figure 9.4

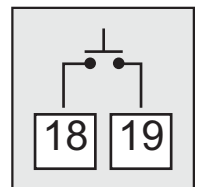

Digital Input For Alarm Acknowledge

- Connect a potential-free contact switch for alarm acknowledgment.
- A transition from OPEN to CLOSE acknowledges the alarm and mutes the relay output.

Figure 9.5

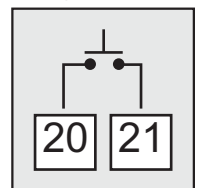

RS485 Communication Port (PC Interface)

Figure 9.6

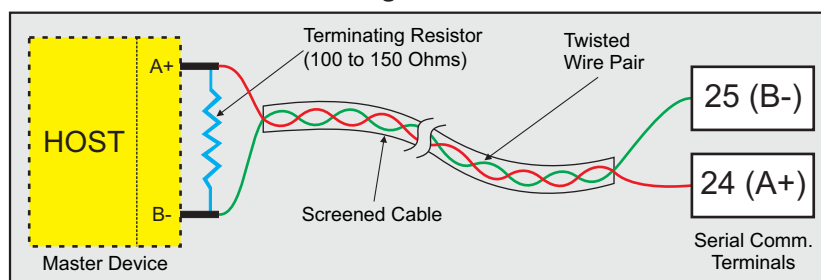

- Connect terminals 24 (A+) and 25 (B-) of the recorder to the corresponding terminals of a host device (e.g., Serial-to-USB or Serial-to-Ethernet converter).
- Use a twisted-pair cable inside a screened shield for reliable noise-free communication.
- Ensure that the cable resistance is ≤ 100 ohms/km (typically 24 AWG or thicker).
- To enhance noise immunity, install a terminating resistor (100-150 ohms) at one end of the line.

Power Supply

1. 85 ~ 265 AC Supply Voltage

Figure 9.7

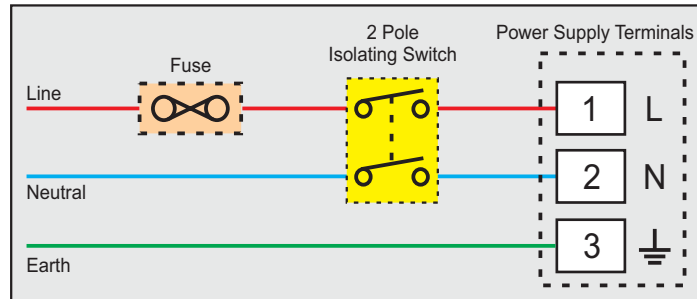

- The device supports a wide voltage range (85-265V AC).
- Use a well-insulated copper conductor of at least 0.5mm² for power supply connections.
- Ensure proper polarity:
 - L (Line) : Live terminal
 - N (Neutral) : Neutral terminal
 - Earth (Ground) : Protective Earth terminal
- External Protection:
 - Install a 2-pole isolating switch for safety.
 - Use a time-lag fuse (1A @ 240V AC) to protect the power supply circuit.

2. 18 to 32 DC Power Supply

Figure 9.8

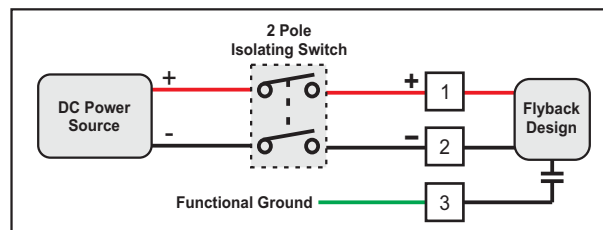

As standard, the Module is supplied with power connections suited for 18 to 32 VDC power source. The accuracy / performance of the Module is not affected by the variations in the supply within specified limits of 18 to 32 VDC. Use well-insulated copper conductor wire of the size not smaller than 0.5mm² for power supply connections ensuring proper polarity as shown in Figure 9.8. The Module is not provided with fuse and power switch. If necessary, mount them separately. Use a slow blow fuse rated for 0.5A current.

For safety and enhanced electrical noise immunity, it is highly recommended to connect Main Power Supply 'Earth' to terminal 3.

Important

- Always ensure secure and correct wiring before powering on the device.
- Follow best wiring practices to minimize noise and ensure reliable operation.
- Improper wiring or failure to follow precautions may result in damage to the recorder.

APPENDIX A DC LINEAR SIGNAL INTERFACE

Overview

Various transmitters generate different signal types, such as mV, V, or mA, with distinct signal ranges. To ensure compatibility with a wide range of transmitters, PPI products offer configurable Signal Type and Range settings.

Common industry-standard signal ranges include:

- 0 to 80 mV, 0 to 160 mV
- 0 to 5 V, 1 to 5 V, 0 to 10 V
- 0 to 20 mA, 4 to 20 mA

Additionally, since transmitters output different signal ranges corresponding to specific process values (e.g., a 1 to 4.5 V signal may represent 5% to 95% RH), PPI products allow users to configure the process value range and resolution.

Required Parameters for Linear Transmitter Interface

For interfacing linear transmitters, the following six parameters must be configured:

Parameter	Definition	Example
Input Type	Defines the standard DC signal type in which the transmitter signal range falls.	4 to 20 mA
Signal Low	The minimum signal value corresponding to the lowest process value.	4.00 mA
Signal High	The maximum signal value corresponding to the highest process value.	20.00 mA
PV Resolution	Defines the smallest measurable unit for the process value.	0.01 psi
Range Low	The process value corresponding to Signal Low.	0.00 psi
Range High	The process value corresponding to Signal High.	5.00 psi

Mathematical Representation

The relationship between transmitter signal values and the corresponding process values follows a straight-line equation:

$$Y = mX + C$$

Where;

- X : Signal Value from Transmitter
- Y : Process Value Corresponding to X
- C : Process Value Corresponding to X = 0 (Y-intercept)
- m : Slope (Change in Process Value per unit Change in Signal Value)

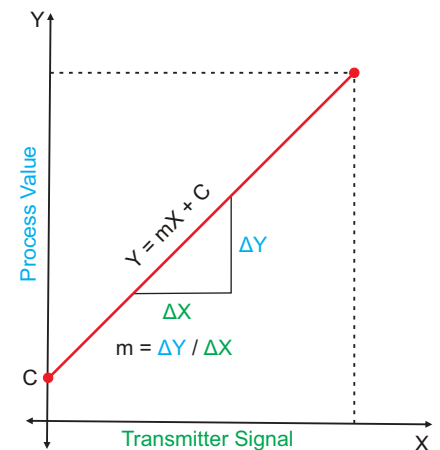

Examples of Transmitter Configurations

Example 1:

Pressure Transmitter (4 to 20 mA corresponding to 0 to 5 psi)

Input Type : 4-20 mA
 Signal Low : 4.00 mA
 Signal High : 20.00 mA
 PV Resolution : 0.01
 Range Low : 0.00
 Range High : 5.00

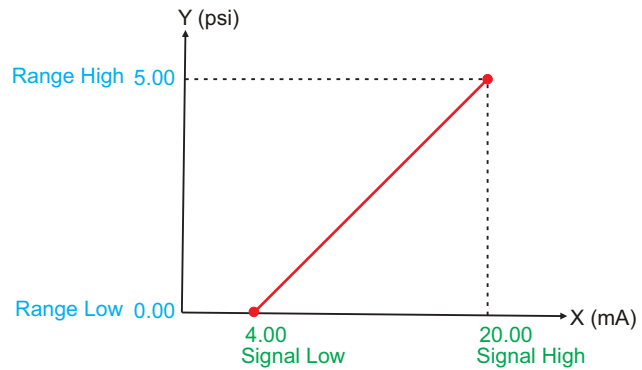

Example 2

Humidity Transmitter (1 to 4.5 V corresponding to 5 to 95 %RH)

Input Type : 0-5 V
 Signal Low : 1.000 V
 Signal High : 4.500 V
 PV Resolution : 0.1
 Range Low : 5.0
 Range High : 95.0

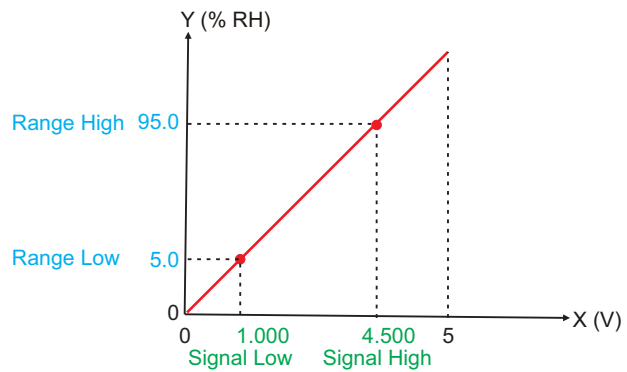

Example 3

Temperature Transmitter (0 to 20 mA corresponding to -50 to 250 °C)

Input Type : 0-20 mA
 Signal Low : 0.00 mA
 Signal High : 20.00 mA
 PV Resolution : 0.1
 Range Low : -50.0
 Range High : 250.0

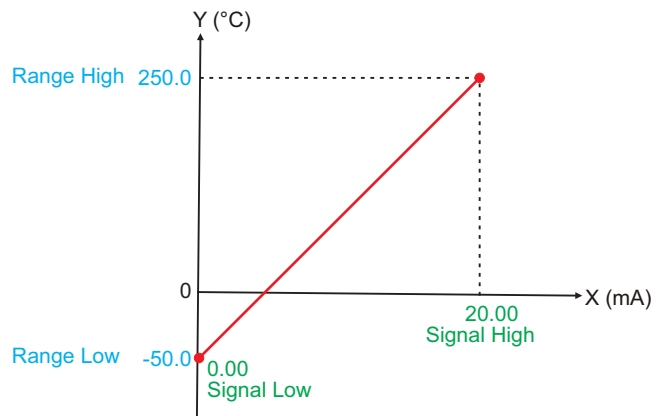

APPENDIX B LOW / HIGH CLIPPING

Overview

For mA, mV, or V inputs, the measured process value (PV) is calculated based on the configured Signal Low and Signal High values, which correspond to the PV Range Low and PV Range High settings. Low and High Clipping allows users to restrict PV values within a specific operational range to suppress unwanted out-of-range values.

Example: Flow Rate Measurement

A flow transmitter outputs a signal between 4 to 20 mA, corresponding to a flow rate of 0.0 to 100.0 LPM (Liters per Minute). However, if the system is designed for a maximum flow rate of 75.0 LPM, then only the signal range 4 to 16 mA is relevant. Without clipping, any signal value outside this range would result in incorrect process values.

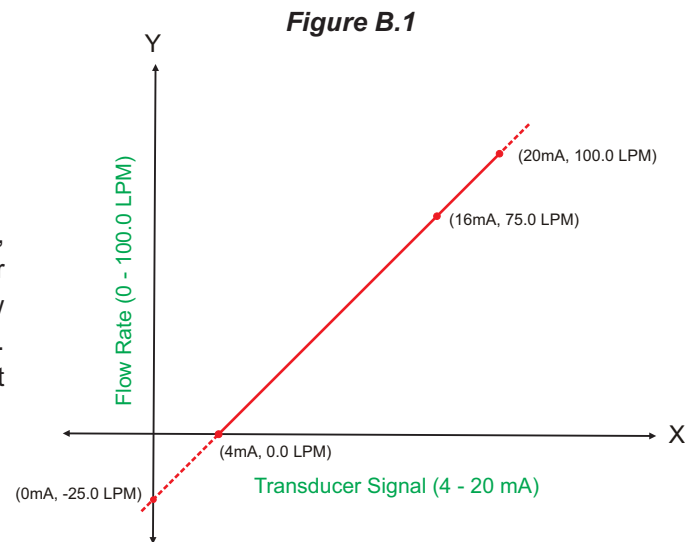

Low & High Clipping Implementation

To prevent out-of-range readings:

- Enable Low Clipping: Suppresses PV values below the Signal Low threshold.
- Enable High Clipping: Restricts PV values exceeding the Signal High threshold.

Example Parameter Configuration for Clipping

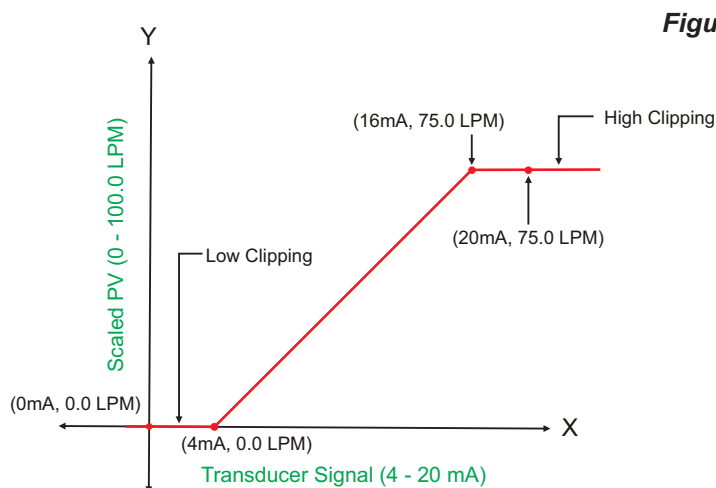

PV Range Low	: 0.0
PV Range High	: 100.0
Enable Low Clipping	: Yes
Low Clip Value	: 0.0
Enable High Clipping	: Yes
High Clip Value	: 75.0

Summary

- Low Clipping ensures that the PV does not drop below the defined minimum.
- High Clipping ensures that the PV does not exceed the defined maximum.
- This feature is useful for applications where operating limits are predefined and must be strictly followed.

VERSION HISTORY

Version	Release Date	Remark
01.01	08/12/2025	Initial Release.
01.02	15/05/2026	1. In USB interface type, the online data is made available on PC port with settable Device ID, Baud Rate, and Parity. 2. In Batch Mode-Time setting, the HH/MM separator changed from (.) to (:). HH.MM → HH:MM



Process Precision Instruments (An ISO 9001 : 2008 Company)

📍 101, Diamond Industrial Estate, Navghar, Vasai Road (E), Dist. Palghar - 401210, Maharashtra, India
📞 Sales : 8208199048 / 8208141446 Support : 07498799226 / 08767395333
✉️ sales@ppiindia.net 🖱️ www.ppiindia.net