

neuro 200 / neuro 200L

Universal Input with inbuilt 24 VDC Transmitter Supply
32 Point User Defined Linearization
2 x Alarm Output & Retransmission Analog Output
1/16 DIN (48x48) & 1/4 DIN (96x96) Size Options

Process Precision Instruments
Vasai Road (E), Dist. Palghar - 401210,
Maharashtra, India

www.ppiindia.net

User Manual

48x48



96x96



CONTENTS

1. FRONT PANEL LAYOUT	1
2. BASIC OPERATION	3
3. SET-UP MODE ACCESS AND OPERATION	6
4. PAGE-10 : ALARM PARAMETERS	8
5. PAGE-11 : RETRANSMISSION PARAMETERS	10
6. PAGE-12 : INPUT CONFIGURATION	11
7. PAGE-13 : SUPERVISORY PARAMETERS	16
8. PAGE-33 : USER LINEARISATION PARAMETERS	17
9. MECHANICAL INSTALLATION	18
10. ELECTRICAL CONNECTIONS	20
11. MODBUS MAPPING	24
APPENDIX-A : HANDLING DECIMAL VALUES IN MODBUS REGISTERS	28
APPENDIX-B : DC LINEAR SIGNAL INTERFACE	30

Section 1 FRONT PANEL LAYOUT

The instrument front panel comprises of digital readouts, LED indicators and tactile keys as shown in Figure 1.1(a) : 48x48 & Figure 1.1(b) : 96x96 below.

Figure 1.1(a) : 48x48

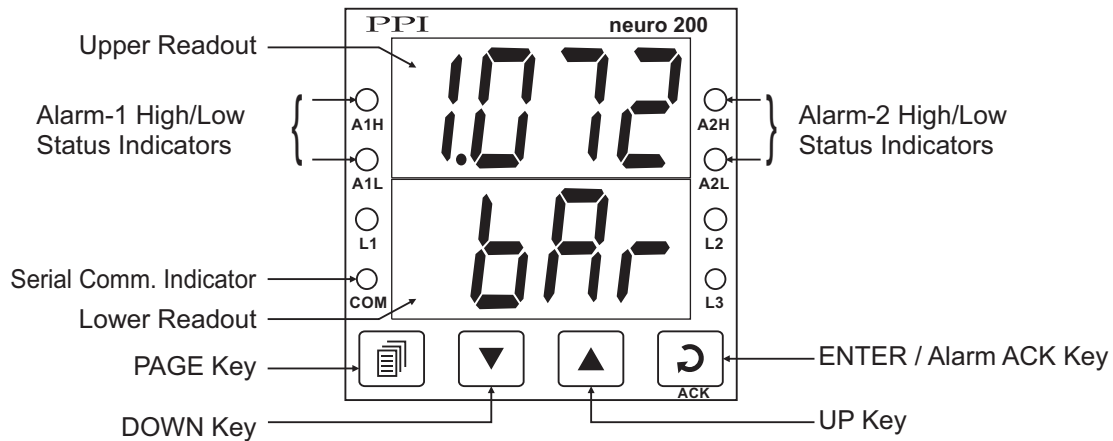
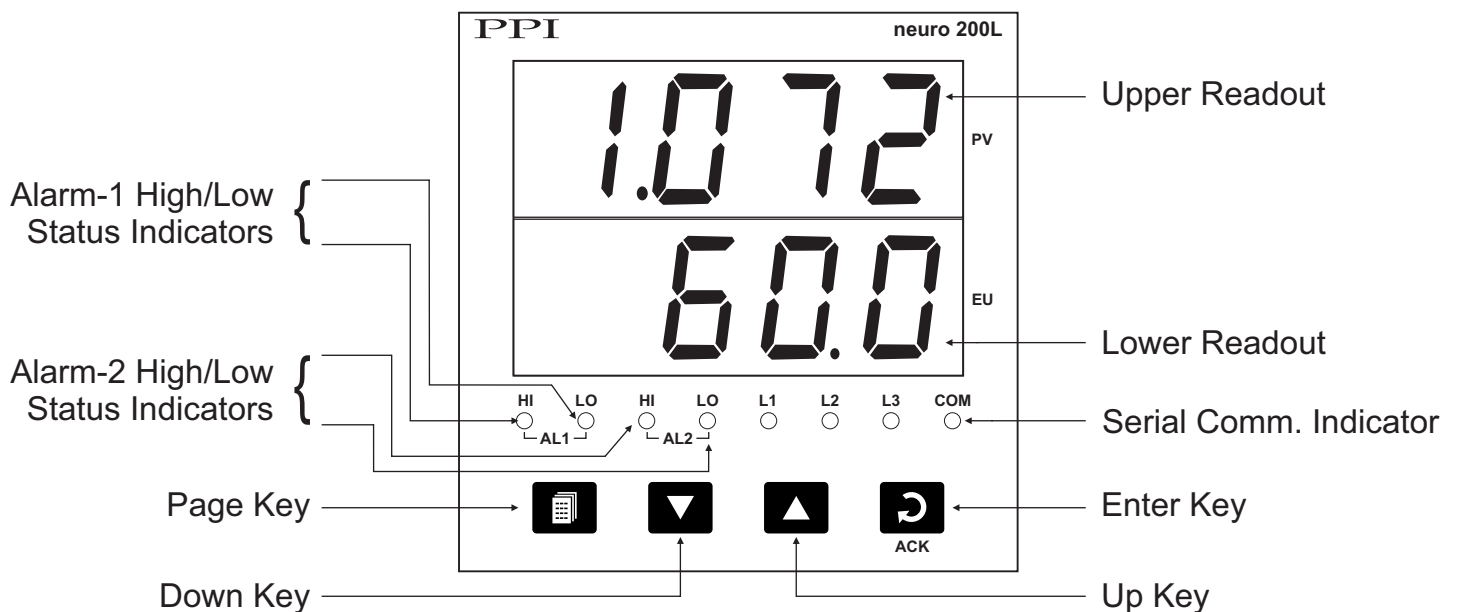

Figure 1.1(b) : 96x96



READOUTS

The Upper Readout is a 4 digit, 7-segment bright green LED display and usually displays the PV (Process Value). In Set-up Mode, the Upper Readout displays parameter values/options.

The Lower Readout is a 4 digit, 7-segment bright green LED display and usually displays Process Value Units. In case of any active Alarm(s), the Lower Readout flashes Alarm Status information. In Set-up Mode, the Lower Readout displays the names (identifier tags) for the parameters.

INDICATORS

There are 8 front panel red LED indicators. These indicators show various statuses. The Table 1.1 below lists each LED indicator (identified by the front panel legend) and the associated status it indicates.





Table 1.1

Indicator		Function
48x48	96x96	
A1H	AL1 { HI LO	Flashes when Alarm-1 high limit is crossed.
A1L		Flashes when Alarm-1 low limit is crossed.
A2H	AL2 { HI LO	Flashes when Alarm-2 high limit is crossed.
A2L		Flashes when Alarm-2 low limit is crossed.
L1, L2, L3		Unused
COM		Serial Communication Status. Flashes when data is being exchanged with Master Device.

KEYS

The Table 1.2 lists the four front panel keys and the associated function.

Table 1.2

Symbol	Key	Function
	PAGE	Press to enter or exit set-up mode.
	DOWN	Press to decrease the parameter value. Pressing once decreases the value by one count; keeping pressed speeds up the change.
	UP	Press to increase the parameter value. Pressing once increases the value by one count; keeping pressed speeds up the change.
	ENTER	Press to store the set parameter value and to scroll to the next parameter on the PAGE.



Section 2 BASIC OPERATIONS

POWER-UP

Upon power-up the instrument executes the following sequence of operations.

- All displays and indicators are lit on for approximately 3 seconds to check any display segment failure.
- Displays instrument model name on the Upper Readout and the firmware version on the Lower Readout, for approximately one second. This helps user to verify features and refer to the correct documents versions.

MAIN DISPLAY MODE

After the Power-up display sequence, the Upper Readout starts showing the measured PV (Process Value) and the Lower Readout displays the user set Units for Process Value. This is the MAIN Display Mode that shall be used most often.



Alarm Status Information

In case of any Alarm (or Alarms) becoming active, the Lower Readout flashes the related Alarm details in the format 'Ax.YY', where x is the Alarm Number (1 or 2) and YY is the Alarm Type (Lo or Hi). For example; if Alarm -1 is active and the set Alarm Type is Low then the Lower Readout flashes (A1.Lo). In case of multiple Alarms, each Alarm Status is flashed sequentially with 1 Seconds interval.

PV Error Indications

The PV Error type is flashed on the Upper Readout. For different errors and the causes, refer Table 2.1 below.

Table 2.1

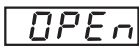
Message	Error Type	Cause
	Over-range	PV above Max. Range
	Under-range	PV below Min. Range
	Sensor Open	Thermocouple / RTD broken

ALARM STATUS UNDER PV ERROR CONDITIONS

For Alarm activation, the under-range condition is treated as minimum PV, whereas the over-range and open conditions are treated as maximum PV. Thus, Process High alarm activates under *Over-range / Open error*. Similarly, Process Low alarm activates under *Under-range error*.

OPERATOR PAGE AND PARAMETERS

The parameters that require frequent settings are organized on a separate page, called the Operator Page. The availability of operator parameters is controlled at supervisory level and the parameter setting cannot be locked by the Master Lock.

Accessing Operator Page & Adjusting Parameters

Step through the following sequence to open the operator page and to adjust the operator parameter values.

1. Press and release PAGE key. The Lower Readout shows (PAGE) and Upper Readout shows (0).
2. Press and release ENTER key. The Lower Readout shows prompt for the first available operator parameter and the Upper Readout shows value for the parameter.
3. Use UP / DOWN keys to adjust the value and then press ENTER key to store the set value and scroll to next parameter.



The indicator automatically reverts to MAIN Display Mode upon scrolling through the last operator parameter. Alternatively, use PAGE key to return to MAIN Display Mode.

The operator parameters are described in Table 2.2. Note that the parameters presented on Operator Page depend upon the functions selected/enabled and supervisory level permissions. The operator parameter list mainly includes :

- a) Min / Max Process Monitoring Parameters.
- b) Setpoint Values for Alarm-1 and Alarm-2.

Table 2.2

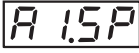
Parameter Description	Settings (Default Value)
<p>ALARM ACKNOWLEDGE ACP</p> <p>Set this parameter value to 'Yes' to acknowledge any pending Alarm(s) to de-activate alarm relay(s). This parameter is available only when any alarm(s) is active and not latched.</p> <p>(Alternatively, use ENTER key to acknowledge pending Alarm(s)).</p>	<div style="display: flex; flex-direction: column; align-items: center;"> <div style="display: flex; align-items: center; margin-bottom: 5px;"> <div style="border: 1px solid black; padding: 2px; margin-right: 5px;">no</div> No </div> <div style="display: flex; align-items: center; margin-bottom: 5px;"> <div style="border: 1px solid black; padding: 2px; margin-right: 5px;">YES</div> Yes </div> <p>(Default : No)</p> </div>
<p>MAXIMUM PV Hi</p> <p>This indicates the highest value attained by the Process Value. This is a read only value and is available only if Min/Max monitoring is enabled.</p>	<p>View Only (Default : NA)</p>
<p>MINIMUM PV Lo</p> <p>This indicates the lowest value attained by the Process Value. This is a read only value and is available only if Min/Max monitoring is enabled.</p>	<p>View Only (Default : NA)</p>
<p>RESET COMMAND rSt</p> <p>Available only if Min/Max monitoring is enabled. This feature clears the current Min/Max values and starts afresh monitoring the PV for new highest and lowest values.</p>	<div style="display: flex; flex-direction: column; align-items: center;"> <div style="display: flex; align-items: center; margin-bottom: 5px;"> <div style="border: 1px solid black; padding: 2px; margin-right: 5px;">no</div> No </div> <div style="display: flex; align-items: center; margin-bottom: 5px;"> <div style="border: 1px solid black; padding: 2px; margin-right: 5px;">YES</div> Yes </div> <p>(Default : No)</p> </div>

Parameter Description	Settings (Default Value)
<p>RESET PASSWORD </p> <p>For resetting the Min/Max values, set the reset command to 'Yes' and then enter the correct password.</p>	<p>0 to 250 (Default :0)</p>
<p>ALARM-1 SETPOINT </p> <p>The setpoint for Alarm-1. This parameter is not available if the selected Alarm-1 type is 'None'.</p>	<p>Min to max Range specified for the selected Input Type (Default : Min or Max Range)</p>
<p>ALARM-2 SETPOINT </p> <p>The setpoint for Alarm-2. This parameter is not available if the selected Alarm-2 type is 'None'.</p>	<p>Min to max Range specified for the selected Input Type (Default : Min or Max Range)</p>



Section 3

SET-UP MODE : ACCESS AND OPERATION

The various parameters are arranged in different groups, called PAGES, depending upon the functions they represent. Each group is assigned a unique numeric value, called PAGE NUMBER, for its access.

The parameters are always presented in a fixed format: The Lower Readout displays the parameter prompt (Identification Name) and the Upper Readout displays the set value. The parameters appear in the same sequence as listed in their respective sections.

SET-UP MODE

The Set-up Mode allows the user to view and modify the parameter values. Follow the steps below for setting the parameter values:

1. Press and release PAGE key. The Lower Readout shows PAGE and the Upper Readout shows page number 0. Refer Figure 3.1.
2. Use UP / DOWN keys to set the desired PAGE NUMBER.
3. Press and release ENTER key. The Lower Readout shows the prompt for the first parameter listed in the set PAGE and the Upper Readout shows its current value. If the entered PAGE NUMBER is invalid (contains no parameter list or any associated function), the indicator reverts to the MAIN Display Mode.
4. Press and release the ENTER key until the prompt for the required parameter appears on the Lower Readout. (The last parameter in the list rolls back to the first parameter).
5. Use UP / DOWN keys to adjust the parameter value. (The display flashes if UP key is pressed after reaching the maximum value or DOWN key is pressed after reaching the minimum value).
6. Press and release the ENTER key. The new value gets stored in the indicator's non-volatile memory and the next parameter in the list is displayed.

The Figure 3.1 illustrates the example of altering the value for the parameter 'Input type'.

Figure 3.1

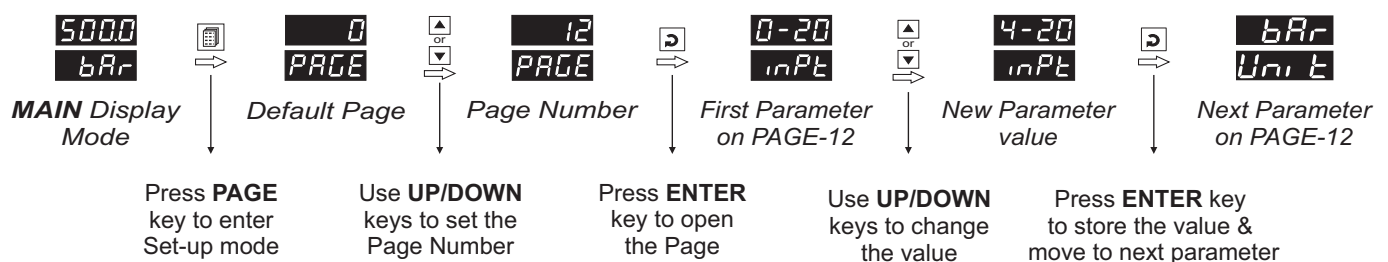

Notes

1. Each page contains a fixed list of parameters that are presented in a pre-determined sequence. Note however that availability of a few parameters, called Conditional Parameters, depend upon the settings for some other parameters. For example, the parameter 'Alarm Setpoint' is available if corresponding 'Alarm type' is set to other than 'none'.
2. To exit the set-up mode and return to the MAIN Display Mode, press and release PAGE key.
3. If no key is pressed for approximately 30 seconds, the set-up mode times out and reverts to the MAIN Display Mode.

MASTER LOCKING

The indicator facilitates locking all the PAGES (except Operator PAGE) by applying Master Lock Code. Under Locking, the parameters are available for *view only* and cannot be adjusted. The Master Lock, however, does not lock the operator parameters. This feature allows protecting the rather less frequently used parameters against any inadvertent changes while making the frequently used operator parameters still available for any editing.

For enabling / disabling the Lock, step through the following sequence:

Locking

1. Press and release PAGE key while the indicator is in the MAIN Display Mode. The Lower Readout shows PAGE and the Upper Readout shows 0.
2. Use UP / DOWN keys to set the Page Number to 123 on the Upper Readout.
3. Press and release ENTER key. The indicator returns to the MAIN Display Mode with the Lock enabled.

The Figure 3.2 below illustrates the Locking procedure.

Figure 3.2

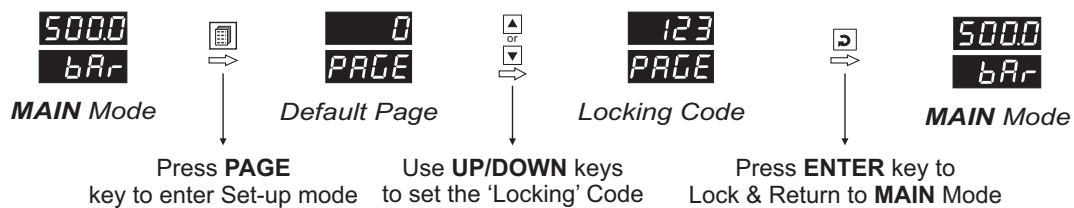

UnLocking

Repeat the Locking procedure twice for unlocking.



Section 4

PAGE-10 : ALARM PARAMETERS

The parameters required for configuring Alarms are grouped on **PAGE-10**. The configuration includes selecting the type of Alarm, setting the hysteresis value, enabling / disabling start-up Alarm suppression, etc. Refer Table 4.1 for parameter description & settings.

Table:4.1

Parameter Description	Settings (Default Value)
ALARM-1 TYPE AL_1 Select the Alarm-1 activation type. Selecting 'None' will disable the alarm and suppress all the related parameters for Alarm-1.	none None P_Lo Process Low P_Hi Process High (Default : None)
ALARM-1 SETPOINT A1SP Sets the Process High or Process Low limit for Alarm-1.	Min. to Max. Range specified for the selected Input Type (Default : Min or Max Range)
ALARM-1 HYSTERESIS A1HY Sets differential (dead) band between Alarm-1 ON and OFF states.	1 to 999 or 0.1 to 999.9 (Default : 2.0)
ALARM-1 INHIBIT A1IH Set to Yes to suppress Alarm-1 activation upon power-up (process start-up) condition.	no No YES Yes (Default :Yes)
ALARM-1 LOGIC A1LG Select 'Normal' if Alarm-1 relay is to activate an Audio / Visual alarm. Select 'Reverse' for Tripping (cut-off) the system.	norm Normal rev Reverse (Default : Normal)
ALARM-1 LATCH A1LT No The Relay switches ON/OFF with Alarm switching. Yes The Relay Output switches (ON for Normal Logic / OFF for Reverse Logic) upon Alarm activation. However, Alarm de-activation does not affect the Relay status. The Relay status can only be regained by pressing 'Acknowledge-key' provided the Alarm has de-activated.	no No YES Yes (Default :No)

Parameter Description	Settings (Default Value)
<p>ALARM-2 TYPE AL_2</p> <p>Select the Alarm-2 activation type. Selecting 'None' will disable the alarm and suppress all the related parameters for Alarm-2.</p>	<p>none None P_Lo Process Low P_Hi Process High (Default : None)</p>
<p>ALARM-2 SETPOINT A2SP</p> <p>Sets the Process High or Process Low limit for Alarm-2.</p>	<p>Min. to Max. Range specified for the selected Input Type (Default : Min/Max Range)</p>
<p>ALARM-2 HYSTERESIS A2HY</p> <p>Sets differential (dead) band between Alarm-2 ON and OFF states.</p>	<p>1 to 999 or 0.1 to 999.9 (Default : 2.0)</p>
<p>ALARM-2 INHIBIT A2IH</p> <p>Set to Yes to suppress Alarm-2 activation upon power-up (process start-up) condition.</p>	<p>no No YES Yes (Default :Yes)</p>
<p>ALARM-2 LOGIC A2LG</p> <p>Select 'Normal' if Alarm-2 relay is to activate an Audio / Visual alarm. Select 'Reverse' for tripping (cut-off) the system.</p>	<p>norm Normal rev Reverse (Default : Normal)</p>
<p>ALARM-2 LATCH A2LT</p> <p>No The Relay switches ON/OFF with Alarm switching.</p> <p>Yes The Relay Output switches (ON for Normal Logic / OFF for Reverse Logic) upon Alarm activation. However, Alarm de-activation does not affect the Relay status. The Relay status can only be regained by pressing 'Acknowledge-key' provided the Alarm has de-activated.</p>	<p>no No YES Yes (Default :No)</p>









Section 5

PAGE-11 : RETRANSMISSION PARAMETERS

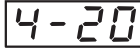
The parameters required for configuring *Retransmission* are grouped on **PAGE-11**. The configuration includes selecting the Output type, Recorder Low & High settings etc. Refer Table 5.1 for parameter description & settings.

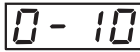
Table 5.1

Parameter Description	Settings (Default Value)
<p>RECORDER (RETRANSMISSION) OUTPUT TYPE </p> <p>Select Output Signal type in accordance with the hardware module fitted. Select 0-20 or 4-20 mA, if Current output module is fitted. Select 0-5 or 0-10 V, if Voltage output module is fitted.</p>	<p> 0 to 20 mA  4 to 20 mA  0 to 5 Volts  0 to 10 Volts (Default : 0 to 20 mA)</p>
<p>RECORDER (RETRANSMISSION) LOW </p> <p>Set the minimum Process Value (PV) that shall correspond to the minimum recorder output signal level (0mA or 4mA or 0V).</p>	<p>Min. to Max. Range specified for the selected Input Type (Default : -200)</p>
<p>RECORDER (RETRANSMISSION) HIGH </p> <p>Set the maximum Process Value (PV) that shall correspond to the maximum recorder output signal level (20 mA or 10 V or 5 V).</p>	<p>Min. to Max. Range specified for the selected Input Type (Default : 1376)</p>



Section 6

PAGE-12 : INPUT CONFIGURATION PARAMETERS















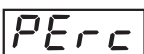



The indicator is needs to be appropriately configured in terms of input and other features like digital filter etc. The **PAGE-12** presents Input configuration parameters that are listed below in Table 6.1 .

Table 6.1

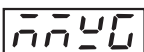
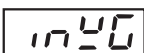
Parameter Description	Settings (Default Value)																											
INPUT TYPE InPt Select Input type in accordance with the type of Thermocouple or RTD sensor or transducer output connected for process value measurement. Ensure proper hardware jumper settings, if required.	Refer Table 6.3 (Default : Type K)																											
UNITS Unit Select Temperature units in °C or °F for Thermocouple or Pt100 sensor. For DC Linear input (mA/mV/V), Select appropriate Units from the list in Table 6.2. Note however that the selected Units are for the purpose of Lower Readout indication only.	Refer Table 6.2 (Default : °C)																											
SIGNAL RANGE LOW SGLo This parameter is available only if the selected input type is DC Voltage / Current and defines the transmitter output signal value corresponding to Range Low process value. Refer <i>Appendix-B : DC Linear Signal Interface</i> for details.	<table border="1"> <thead> <tr> <th>Input Type</th> <th>Settings</th> <th>Default</th> </tr> </thead> <tbody> <tr> <td>0 to 20 mA</td> <td>0.00 to Signal High</td> <td>0.00</td> </tr> <tr> <td>4 to 20 mA</td> <td>4.00 to Signal High</td> <td>4.00</td> </tr> <tr> <td>Reserved</td> <td>0.0 to Signal High</td> <td>0.0</td> </tr> <tr> <td>0 to 80 mV</td> <td>0.00 to Signal High</td> <td>0.00</td> </tr> <tr> <td>0 to 1.25 V</td> <td>0.000 to Signal High</td> <td>0.000</td> </tr> <tr> <td>0 to 5 V</td> <td>0.000 to Signal High</td> <td>0.000</td> </tr> <tr> <td>0 to 10 V</td> <td>0.00 to Signal High</td> <td>0.00</td> </tr> <tr> <td>1 to 5 V</td> <td>1.000 to Signal High</td> <td>1.000</td> </tr> </tbody> </table>	Input Type	Settings	Default	0 to 20 mA	0.00 to Signal High	0.00	4 to 20 mA	4.00 to Signal High	4.00	Reserved	0.0 to Signal High	0.0	0 to 80 mV	0.00 to Signal High	0.00	0 to 1.25 V	0.000 to Signal High	0.000	0 to 5 V	0.000 to Signal High	0.000	0 to 10 V	0.00 to Signal High	0.00	1 to 5 V	1.000 to Signal High	1.000
Input Type	Settings	Default																										
0 to 20 mA	0.00 to Signal High	0.00																										
4 to 20 mA	4.00 to Signal High	4.00																										
Reserved	0.0 to Signal High	0.0																										
0 to 80 mV	0.00 to Signal High	0.00																										
0 to 1.25 V	0.000 to Signal High	0.000																										
0 to 5 V	0.000 to Signal High	0.000																										
0 to 10 V	0.00 to Signal High	0.00																										
1 to 5 V	1.000 to Signal High	1.000																										
SIGNAL RANGE HIGH SGHi This parameter is available only if the selected input type is DC Voltage / Current and defines the transmitter output signal value corresponding to Range High process value. Refer <i>Appendix-B : DC Linear Signal Interface</i> for details.	<table border="1"> <thead> <tr> <th>Input Type</th> <th>Settings</th> <th>Default</th> </tr> </thead> <tbody> <tr> <td>0 to 20 mA</td> <td>Signal Low to 20.00</td> <td>20.00</td> </tr> <tr> <td>4 to 20 mA</td> <td>Signal Low to 20.00</td> <td>20.00</td> </tr> <tr> <td>Reserved</td> <td>Signal Low to 80.00</td> <td>80.00</td> </tr> <tr> <td>0 to 80 mV</td> <td>Signal Low to 80.00</td> <td>80.00</td> </tr> <tr> <td>0 to 1.25 V</td> <td>Signal Low to 1.250</td> <td>1.250</td> </tr> <tr> <td>0 to 5 V</td> <td>Signal Low to 5.000</td> <td>5.000</td> </tr> <tr> <td>0 to 10 V</td> <td>Signal Low to 10.00</td> <td>10.00</td> </tr> <tr> <td>1 to 5 V</td> <td>Signal Low to 5.000</td> <td>5.000</td> </tr> </tbody> </table>	Input Type	Settings	Default	0 to 20 mA	Signal Low to 20.00	20.00	4 to 20 mA	Signal Low to 20.00	20.00	Reserved	Signal Low to 80.00	80.00	0 to 80 mV	Signal Low to 80.00	80.00	0 to 1.25 V	Signal Low to 1.250	1.250	0 to 5 V	Signal Low to 5.000	5.000	0 to 10 V	Signal Low to 10.00	10.00	1 to 5 V	Signal Low to 5.000	5.000
Input Type	Settings	Default																										
0 to 20 mA	Signal Low to 20.00	20.00																										
4 to 20 mA	Signal Low to 20.00	20.00																										
Reserved	Signal Low to 80.00	80.00																										
0 to 80 mV	Signal Low to 80.00	80.00																										
0 to 1.25 V	Signal Low to 1.250	1.250																										
0 to 5 V	Signal Low to 5.000	5.000																										
0 to 10 V	Signal Low to 10.00	10.00																										
1 to 5 V	Signal Low to 5.000	5.000																										
RESOLUTION rSLn (Not Available for Thermocouple Inputs) Set the process value indication resolution (decimal point). All the resolution based parameters (hysteresis, alarm setpoints etc.) then follow this resolution setting. Refer <i>Appendix-B : DC Linear Signal Interface</i> for details.	Refer Table 6.3 (Default : 1)																											

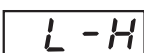
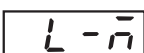
Parameter Description	Settings (Default Value)
<p>DC RANGE LOW r.Lo</p> <p>This parameter is available only if the selected input type is DC Voltage / Current and defines the process value corresponding to the Signal Low value from the transmitter. Refer <i>Appendix-B : DC Linear Signal Interface</i> for details.</p>	<p>-1999 to 9999 (Default : 0.0)</p>
<p>DC RANGE HIGH r.Hi</p> <p>This parameter is available only if the selected input type is DC Voltage / Current and defines the process value corresponding to the Signal High value from the transmitter. Refer <i>Appendix-B : DC Linear Signal Interface</i> for details.</p>	<p>-1999 to 9999 (Default : 100.0)</p>
<p>OFFSET OFSE</p> <p>This value is algebraically added to the measured PV to derive the final PV that is displayed and used for Alarm / Retransmission.</p> <p>Final PV = Measured PV + Offset</p>	<p>-1999 to 9999 or -199.9 to 999.9 (Default : 0)</p>
<p>FILTER F,LT</p> <p>Sets the time constant, in seconds, for the low-pass digital filter applied to the measured PV. The filter helps smoothing / averaging the signal input and removing the undesired noise. The higher the filter value the lower the indication response to the PV changes and vice-a-versa.</p>	<p>0.5 to 60.0 Seconds (in steps of 0.5 Seconds) (Default : 2.0 sec.)</p>

Table-6.2

Lower Readout	Units	MODBUS Index		
	°C	0	Temperature	
	°F	1		
	Kelvin	2		
	Engineering Units	3		
	Percentage	4		
	Pascals	5	Pressure	
	Mpascals	6		
	Kpascals	7		
	Bar	8		
	Milli bar	9		
	PSI	10		
	kg/sq cm	11		
	mm water gauge	12		
	Inches water gauge	13		
	mm mercury	14		
	Torr	15		
	Litres per hour	16		Flow
	Litres per minute	17		
	% Relative Humidity	18		
	% O2	19		
	% CO2	20		
	% Carbon Potential	21		



























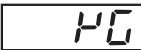

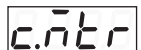











Lower Readout	Units	MODBUS Index	
	volts	22	Electricity
	Amps	23	
	Milli amps	24	
	Milli Volts	25	
	Ohms	26	
	Parts per million	27	
	Revolutions per minute	28	
	Milli seconds	29	Time
	Seconds	30	
	Minutes	31	
	Hours	32	
	PH	33	
	%PH	34	
	Miles per hour	35	
	Milli grams	36	Weight
	Grams	37	
	Kilo grams	38	
	mm (Millimeter)	39	Length / Height / Distance
	cm (Centimeter)	40	
	Meter	41	
	Kilometer	42	
	Foot	43	
	Inch	44	
	Mile	45	

Table 6.3

Option	What it means	Range (Min. to Max.)	Resolution
	Type J Thermocouple	0 to +960°C / +32 to +1760°F	Fixed 1°C / 1°F
	Type K Thermocouple	-200 to +1376°C / +328 to +2508°F	
	Type T Thermocouple	-200 to +385°C / +328 to +725°F	
	Type R Thermocouple	0 to +1770°C / +32 to +3218°F	
	Type S Thermocouple	0 to +1765°C / +32 to +3209°F	
	Type B Thermocouple	0 to +1825°C / +32 to +3317°F	
	Type N Thermocouple	0 to +1300°C / +32 to +2372°F	
	Reserved for customer specific Thermocouple type not listed above. The type shall be specified in accordance with the ordered (optional on request) Thermocouple type.		
	3-wire, RTD Pt100	-199 to +600°C / -328 to +1112°F or -199.9 to 600.0°C / -199.9 to 999.9°F	User settable 1°C / 1°F or 0.1°C / 0.1°F
	0 to 20mA DC current	-1999 to +9999 units	User settable 1 / 0.1 / 0.01/ 0.001 units
	4 to 20mA DC current		
	Reserved		
	0 to 80mV DC voltage		
	0 to 1.25V DC voltage		
	0 to 5.0V DC voltage		
	0 to 10.0V DC voltage		
	1 to 5.0V DC voltage		

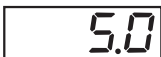

Section 7

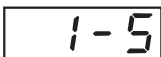
PAGE-13 : SUPERVISORY PARAMETERS

The supervisory level responsibilities include exercising control over operator, making process related decisions and controlling the availability of process data for remote use. The **PAGE-13** parameters allow implementation of supervisory level decisions. The Table 7.1 below lists supervisory parameters.

Table 7.1

Parameter Description	Settings (Default Value)
ALARM SP ADJUSTMENT ON OPERATOR PAGE ALSP Supervisory permission for Alarm setpoint adjustments on Operator Page. Set to 'Enable' for permission.	d56L Disable En6L Enable (Default : Disable)
PROCESS VALUE HIGH-LOW MONITORING HiLo This parameter enables or disables the PV monitoring for Min/Max values. Set to 'Yes' for enabling the feature.	no No YES Yes (Default :No)
PASSWORD FOR RESETTING PV HIGH-LOW CODE This parameter allows protection against inadvertent resetting of Min/Max values. That is, the reset command is executed only if the operator sets the password that matches with this parameter value.	0 to 250 (Default : 0)
SERIAL ID NUMBER id Unique numeric code assigned to the indicator for identification by the host. Set the value as required by the host.	1 to 127 (Default : 1)
BAUD RATE BAUD Communication speed in 'Bits per Second'. Set the value to match with the host baud rate.	4.8 4800 9.6 9600 19.2 19200 (Default : 9.6)
PARITY PARI One of the communication error trapping features. Select the data packet parity as implemented by the host protocol.	nonE None EvEn Even Odd Odd (Default : Even)
SERIAL WRITE PERMISSION CoñE Setting to 'No' disallows the host to set / modify any parameter value. The host, however, can read the value.	no No YES Yes (Default :Yes)











Section 8

PAGE-33 : USER LINEARISATION PARAMETERS

The parameters listed on this **PAGE-33** are used to implement the linearisation curve on the process value represented by the DC linear output of a transmitter. The parameters affect the measured PV only if the 'User Linearisation' feature is 'Enabled' and if the input type is DC Linear. That is, the PV measured using Thermocouple or RTD is not affected by the linearisation parameters. The Table 8.1 below lists the user linearisation parameters.

Table 8.1

Parameter Description	Settings (Default Value)
USER LINEARIZATION SETTING CODE  Protection password for access to the linearisation related parameters. Set to 333 as valid password.	0 to 9999 (Default : 0)
USER LINEARIZATION  Enable / Disable user linearisation feature.	 No  Yes (Default :No)
TOTAL BREAK POINTS  Select number of segments for the purpose of input PV curve linearisation by setting the number of total break points.	2 to 32 (Default : 2)
BREAK POINT NUMBER  Select the break point for which the X, Y co-ordinates are to be set.	1 to 32 (Default : 1)
ACTUAL VALUE FOR BREAK POINT (X CO-ORD)  Set the actual measured (X co-ordinate) value for the selected break point number.	-1999 to 9999 (Default : Undefined)
DERIVED VALUE FOR BREAK POINT (Y CO-ORD)  Set the computed or derived (Y co-ordinate) value for the selected break point number.	-1999 to 9999 (Default : Undefined)



Section 9 MECHANICAL INSTALLATION

OUTER DIMENSIONS

The Figure 9.1(a) : 48x48 & Figure 9.1(b) : 96x96 shows the instrument outer dimensions.

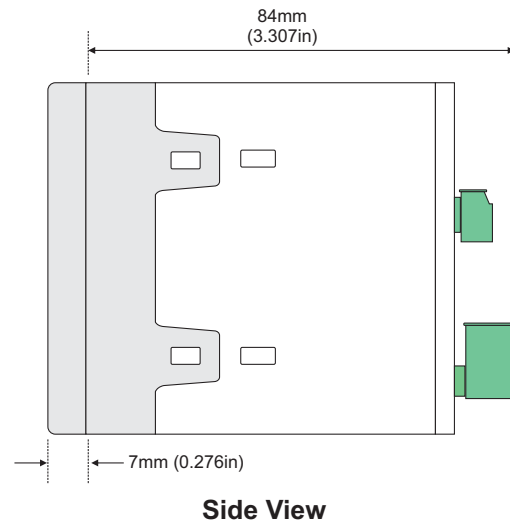
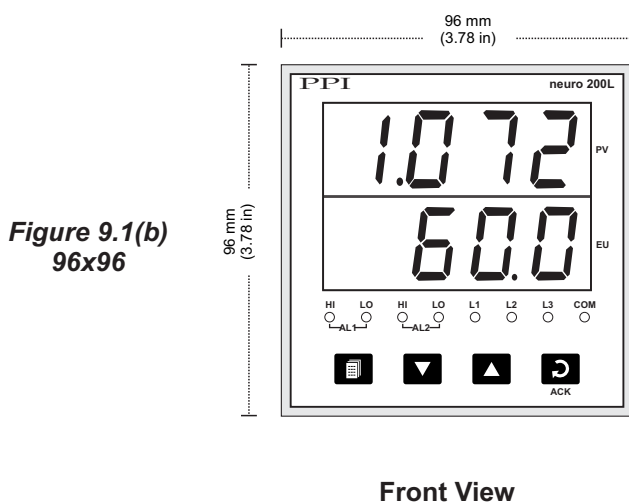
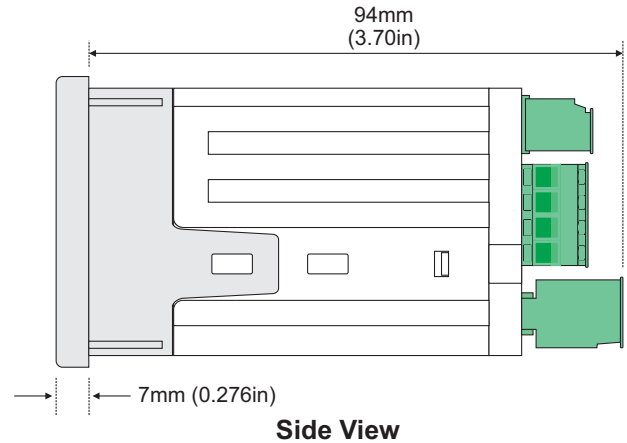
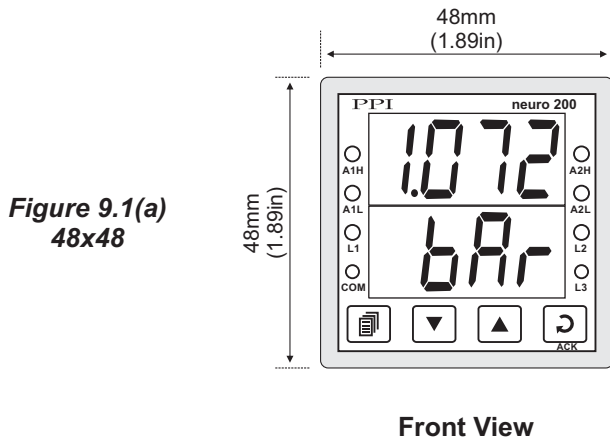
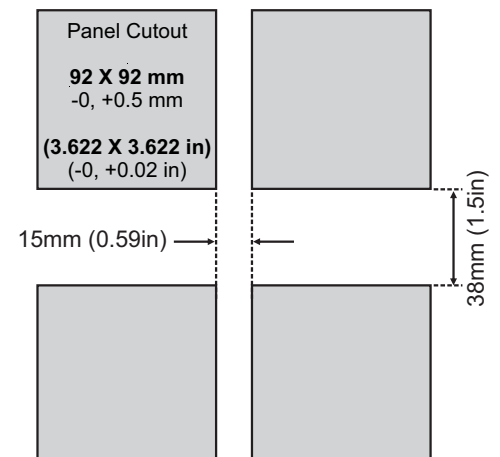
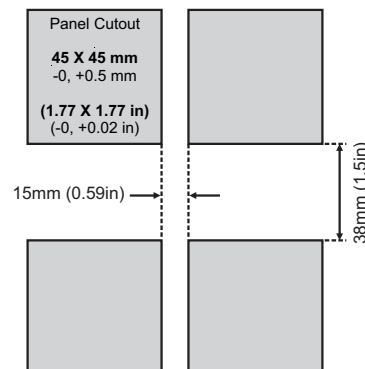

Figure 9.2(a) : 48x48

Figure 9.2(b) : 96x96

PANEL CUTOUT AND RECOMMENDED MINIMUM SPACING

The Figure 9.2(a) : 48x48 & Figure 9.2(b) : 96x96 shows the panel cutout requirements for a single instrument and also the minimum spacing recommended if several instruments are required to be mounted on a single panel.



PANEL MOUNTING

Follow the steps below for mounting the instrument on panel:

1. Prepare a square cutout to the size shown in Figure 9.2.
2. Remove the Panel Mounting Clamp from the instrument Enclosure and insert the rear of the instrument housing through the panel cutout from the front of the mounting panel.
3. Hold the instrument gently against the mounting panel such that it positions squarely against the panel wall, see Figure 9.3. Apply pressure only on the bezel and not on the front label.
4. Insert the mounting clamps on either side of the instrument in the slots provided for the purpose. Rotate the screws clockwise so that they move forward until they push firmly against the rear face of the mounting panel for secured mounting.

Figure 9.3

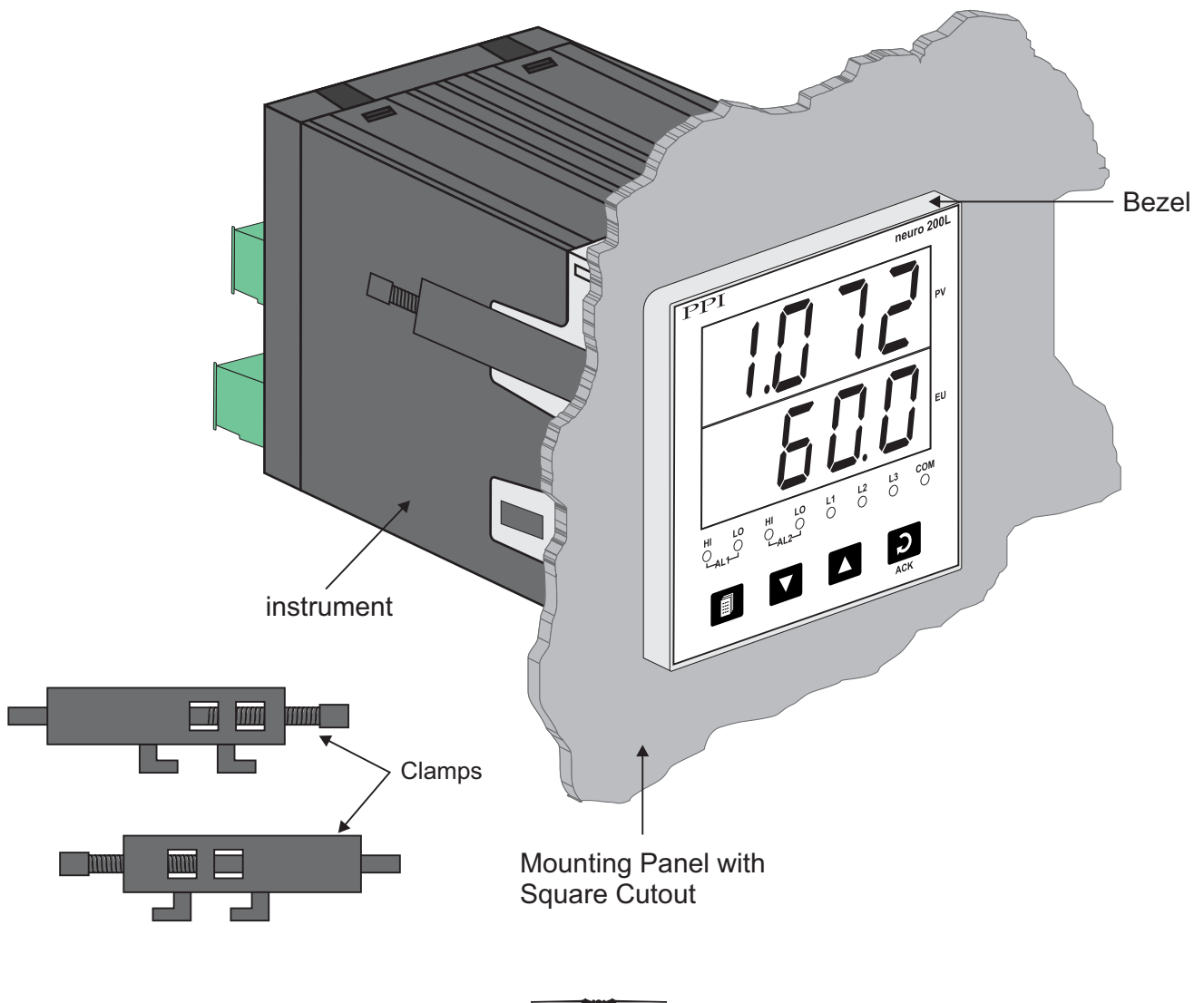

Section 10

ELECTRICAL CONNECTIONS

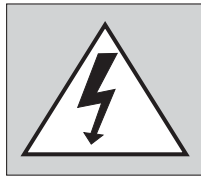

WARNING
MISHANDLING / NEGLIGENCE CAN
RESULT IN PERSONAL DEATH OR
SERIOUS INJURY.

1. The user must rigidly observe the Local Electrical Regulations.
2. Do not make any connections to the unused terminals for making a tie-point for other wires (or for any other reasons) as they may have some internal connections. Failing to observe this may result in permanent damage to the instrument.
3. Run power supply cables separated from the low-level signal cables (like Thermocouple, RTD, DC mA/V signals, etc.). If the cables are run through conduits, use separate conduits for power supply cable and low-level signal cables.
4. Use appropriate fuses and switches, wherever necessary, for driving the high voltage loads to protect the instrument from any possible damage due to high voltage surges of extended duration or short-circuits on loads.
5. Take care not to over-tighten the terminal screws while making connections.
6. Make sure that the instrument supply is switched-off while making/removing any connections or removing the instrument from its enclosure.

CONNECTION DIAGRAM

The connectors provided for wiring are pluggable male-female type. The female parts are soldered on the instrument PCBs while the male parts are with screws and removable. The rear panel electrical wiring connection diagram is shown in Figure 10.1(a) : 48x48 & Figure 10.1(b) : 96x96.

Figure 10.1(a) :
48x48

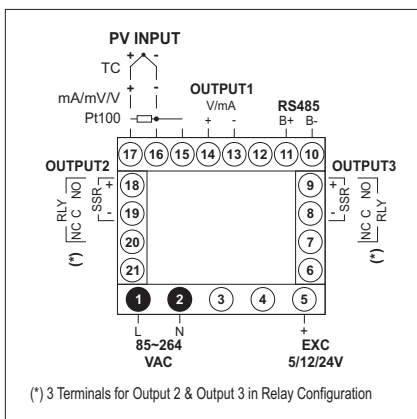
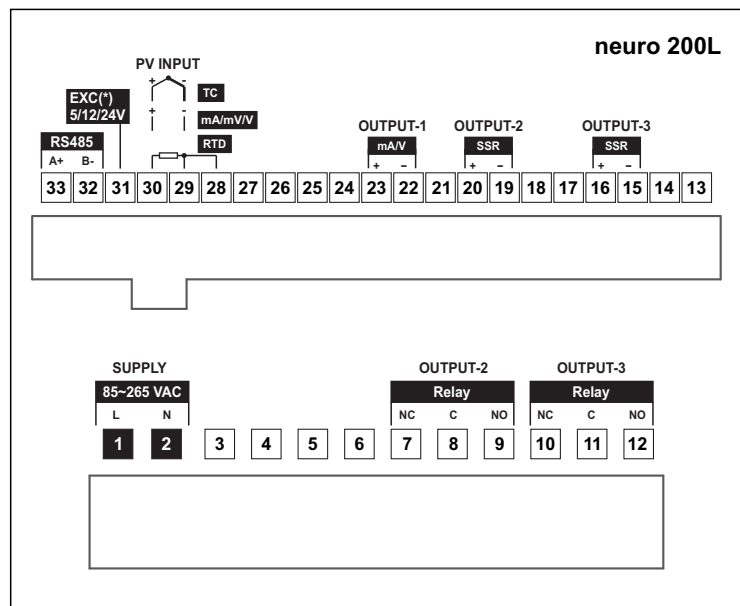

Figure 10.1(b) :
96x96



DESCRIPTIONS

The back panel connections are described as under:

PV INPUT : RTD Pt100, 3-wire / Thermocouple / mA / mV / V

Figure 10.2(a)
RTD Input

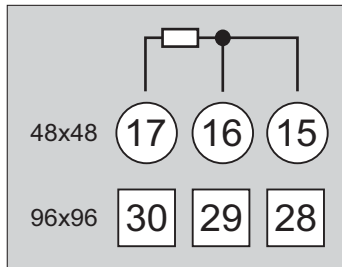

Figure 10.2(b)
Thermocouple Input

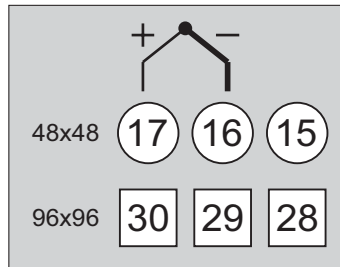
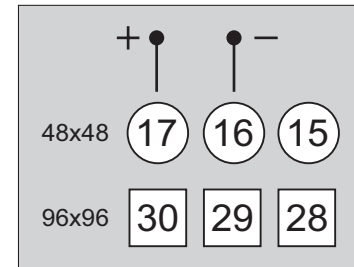

Figure 10.2(c)
mA / mV / V Input



RTD Pt100, 3-wire

Connect single leaded end of RTD bulb to terminal 17/30 and the double leaded ends to terminal 16/29 and 15/28 (interchangeable) as shown in Figure 10.2 (a). Use low resistance copper conductor leads of the same gauge and length. Avoid joints in the cable.

Thermocouple

Connect Thermocouple Positive (+) to terminal 17/30 and Negative (-) to terminal 16/29 as shown in Figure 10.2 (b). Use correct type of extension lead wires or compensating cable. Avoid joints in the cable.

mA / mV / V

Use a shielded twisted pair with the shield grounded at the signal source for connecting mV / V source. Connect common (-) to terminal 17/30 and the signal (+) to terminal 16/29, as shown in Figure 10.2 (c).

OUTPUT-1 : Retransmission - V/mA

OUTPUT-2 : Alarm-1 - Relay
Alarm-1 - SSR

OUTPUT-3 : Alarm-2 - Relay
Alarm-2 - SSR

Output-1
V/mA

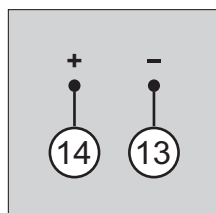
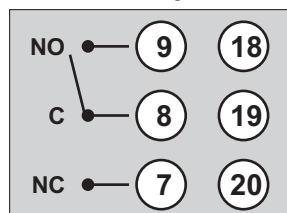

Figure 10.3(a) :
48x48

Output-2 / Output-3
Relay



Output-2 / Output-3
SSR

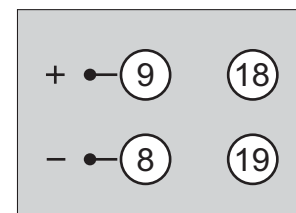
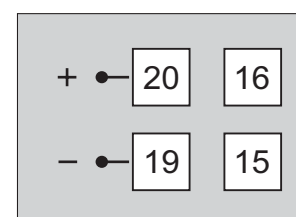
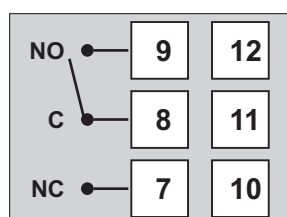
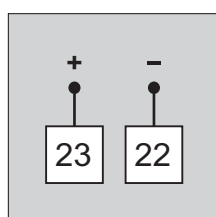

Figure 10.3(b) :
96x96



mA/V Output

The Positive (+) of mA/V is available at Terminal 14 / 23 & the Negative (-) at Terminal 13 / 22.

Relay Output

Potential-free Relay changeover contacts NO (Normally Open) and C (Common) rated 5A/240 VAC (resistive load).

SSR Output

Connect (+) and (-) terminals of SSR to (+) and (-) terminals of instrument, respectively. Use Zero-Crossover, 3 to 30 VDC operated SSR.

EXC 24VDC : Excitation Voltage for Transmitters

The instrument is supplied with 24VDC @ 30 mA power source. This is primarily meant for exciting 2-wire or 4-wire Current / Voltage output transmitters. Please note that only the Source terminal (positive) is provided on the back panel termination. The Sensor negative terminal is used as Return terminal (ground) for excitation output.

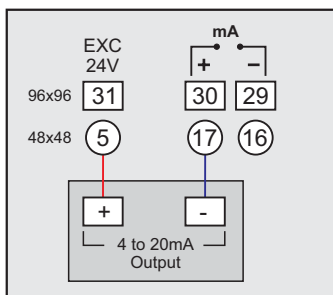

2-wire Current Transmitter

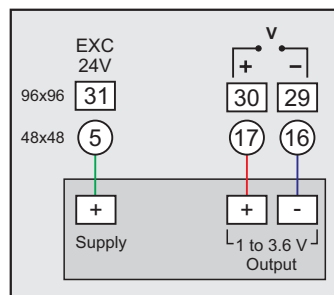

3-wire Voltage Transmitter

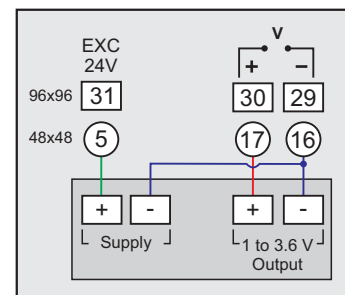

4-wire Voltage Transmitter

RS485 : Serial Communication Port

Connect terminal 11 / 33 and 10 / 32 of the instrument to (A+) and (B-) RS485 terminals of the Master device.

To ensure reliable operation of the Serial Communication Link (without data corruption due to line noise or reflections), use a pair of twisted wires inside screened cable with the terminating resistor (100 to 150 Ohms) at one end, as shown in Figure 10.4 below.

Figure 10.4

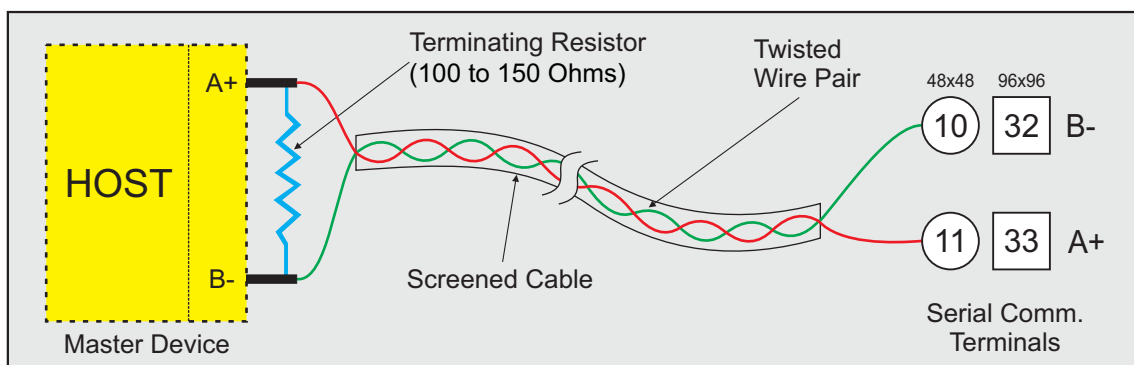

85~264 VAC : Power Supply

The instrument is supplied with power connections suited for 85 to 264 VAC line supply. Use well-insulated copper conductor wire of the size not smaller than 0.5mm^2 for power supply connections. Connect Line (Phase) supply line to terminal 1 and the Neutral (Return) supply line to terminal 2 as shown in Figure 10.5 below. The instrument is not provided with fuse and power switch. If necessary, mount them separately. Use a time lag fuse rated $1\text{A} @ 240\text{ VAC}$.

Figure 10.5

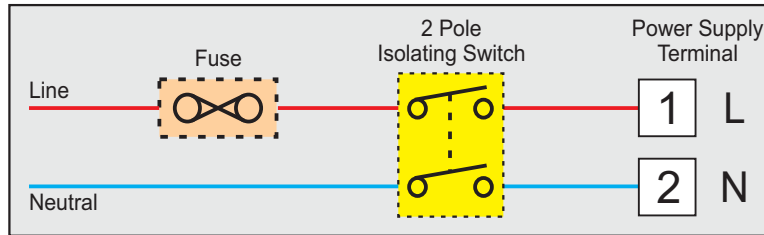

Section 11 MODBUS MAPPING

Table 1 : Read Only Parameters

Parameter	Data Type	Address	Remark								
Parameter Modified through Front Panel Keys	16 bit signed integer	1	<table border="1"> <thead> <tr> <th>Value</th> <th>Meaning</th> </tr> </thead> <tbody> <tr> <td>1</td> <td>One or more parameters are modified using front panel keys since last read.</td> </tr> <tr> <td>0</td> <td>No parameter is modified since last read.</td> </tr> </tbody> </table>	Value	Meaning	1	One or more parameters are modified using front panel keys since last read.	0	No parameter is modified since last read.		
Value	Meaning										
1	One or more parameters are modified using front panel keys since last read.										
0	No parameter is modified since last read.										
Process Value (PV)	16 bit signed integer	2	<p><i>Resolution Based Parameter : Refer Appendix-A</i></p> <p>The following constant counts indicate PV Errors.</p> <table border="1"> <thead> <tr> <th>Value</th> <th>PV Error Type</th> </tr> </thead> <tbody> <tr> <td>-32768</td> <td>Under Range</td> </tr> <tr> <td>+32752</td> <td>Over Range</td> </tr> <tr> <td>+32767</td> <td>Sensor Open</td> </tr> </tbody> </table>	Value	PV Error Type	-32768	Under Range	+32752	Over Range	+32767	Sensor Open
Value	PV Error Type										
-32768	Under Range										
+32752	Over Range										
+32767	Sensor Open										
Minimum Process Value	16 bit signed integer	3	<p><i>Resolution Based Parameter : Refer Appendix-A</i></p>								
Maximum Process Value	16 bit signed integer	4									
Ambient Temperature	16 bit signed integer	5	<p><i>Resolution Based Parameter : Refer Appendix-A</i></p> <p>The measured Ambient Temperature used for thermocouple cold junction compensation.</p> <p>The value is always in °C with 0.1°C resolution.</p>								
Alarm 1 Status	16 bit signed integer	6	<table border="1"> <thead> <tr> <th>Value</th> <th>Status</th> </tr> </thead> <tbody> <tr> <td>0</td> <td>Alarm OFF (Inactive)</td> </tr> <tr> <td>1</td> <td>Alarm ON (Active)</td> </tr> </tbody> </table>	Value	Status	0	Alarm OFF (Inactive)	1	Alarm ON (Active)		
Value	Status										
0	Alarm OFF (Inactive)										
1	Alarm ON (Active)										
Alarm 2 Status	16 bit signed integer	7									
Serial Write Permission	16 bit signed integer	8	<table border="1"> <thead> <tr> <th>Value</th> <th>Status</th> </tr> </thead> <tbody> <tr> <td>0</td> <td>Parameter values can be modified using MODBUS</td> </tr> <tr> <td>1</td> <td>Parameter values can not be modified using MODBUS</td> </tr> </tbody> </table>	Value	Status	0	Parameter values can be modified using MODBUS	1	Parameter values can not be modified using MODBUS		
Value	Status										
0	Parameter values can be modified using MODBUS										
1	Parameter values can not be modified using MODBUS										

Table 2 : Read / Write Parameters

Parameter	Data Type	Address	Remark																																				
Input Type	16 bit signed integer	44	<table border="1"> <thead> <tr> <th>Value</th> <th>Type</th> </tr> </thead> <tbody> <tr><td>0</td><td>Type J Thermocouple</td></tr> <tr><td>1</td><td>Type K Thermocouple</td></tr> <tr><td>2</td><td>Type T Thermocouple</td></tr> <tr><td>3</td><td>Type R Thermocouple</td></tr> <tr><td>4</td><td>Type S Thermocouple</td></tr> <tr><td>5</td><td>Type B Thermocouple</td></tr> <tr><td>6</td><td>Type N Thermocouple</td></tr> <tr><td>7</td><td>Reserved TC (Default: Type J)</td></tr> <tr><td>8</td><td>RTD Pt100, 3-wire</td></tr> <tr><td>9</td><td>0 to 20 mA</td></tr> <tr><td>10</td><td>4 to 20 mA</td></tr> <tr><td>11</td><td>0 to 80 mV</td></tr> <tr><td>12</td><td>Reserved (Default: 0 to 80 mV)</td></tr> <tr><td>13</td><td>0 to 1.25 V</td></tr> <tr><td>14</td><td>0 to 5 V</td></tr> <tr><td>15</td><td>0 to 10 V</td></tr> <tr><td>16</td><td>1 to 5 V</td></tr> </tbody> </table>	Value	Type	0	Type J Thermocouple	1	Type K Thermocouple	2	Type T Thermocouple	3	Type R Thermocouple	4	Type S Thermocouple	5	Type B Thermocouple	6	Type N Thermocouple	7	Reserved TC (Default: Type J)	8	RTD Pt100, 3-wire	9	0 to 20 mA	10	4 to 20 mA	11	0 to 80 mV	12	Reserved (Default: 0 to 80 mV)	13	0 to 1.25 V	14	0 to 5 V	15	0 to 10 V	16	1 to 5 V
Value	Type																																						
0	Type J Thermocouple																																						
1	Type K Thermocouple																																						
2	Type T Thermocouple																																						
3	Type R Thermocouple																																						
4	Type S Thermocouple																																						
5	Type B Thermocouple																																						
6	Type N Thermocouple																																						
7	Reserved TC (Default: Type J)																																						
8	RTD Pt100, 3-wire																																						
9	0 to 20 mA																																						
10	4 to 20 mA																																						
11	0 to 80 mV																																						
12	Reserved (Default: 0 to 80 mV)																																						
13	0 to 1.25 V																																						
14	0 to 5 V																																						
15	0 to 10 V																																						
16	1 to 5 V																																						
PV Units	16 bit signed integer	45	Refer table 6.2, Column 'MODBUS Index' for MODBUS Values corresponding to various units.																																				
PV Resolution	16 bit signed integer	46	<table border="1"> <thead> <tr> <th colspan="2">For RTD Pt100 Input</th> </tr> <tr> <th>Value</th> <th>Resolution</th> </tr> </thead> <tbody> <tr><td>0</td><td>1</td></tr> <tr><td>1</td><td>0.1</td></tr> <tr> <th colspan="2">For mV/V/mA Input</th> </tr> <tr> <th>Value</th> <th>Resolution</th> </tr> <tr><td>0</td><td>1</td></tr> <tr><td>1</td><td>0.1</td></tr> <tr><td>2</td><td>0.01</td></tr> <tr><td>3</td><td>0.001</td></tr> </tbody> </table>	For RTD Pt100 Input		Value	Resolution	0	1	1	0.1	For mV/V/mA Input		Value	Resolution	0	1	1	0.1	2	0.01	3	0.001																
For RTD Pt100 Input																																							
Value	Resolution																																						
0	1																																						
1	0.1																																						
For mV/V/mA Input																																							
Value	Resolution																																						
0	1																																						
1	0.1																																						
2	0.01																																						
3	0.001																																						

Parameter	Data Type	Address	Remark								
Signal Low	16 bit signed integer	67	<i>Resolution Based Parameter : Refer Appendix-A</i>								
Signal High	16 bit signed integer	68									
PV Range Low	16 bit signed integer	47									
PV Range High	16 bit signed integer	48									
Offset for PV	16 bit signed integer	49									
Digital Filter Time Constant	16 bit signed integer	50	<i>Resolution Based Parameter : Refer Appendix-A</i> Settable in multiples of 0.5 Seconds. Non-multiples of 0.5 are automatically converted to the nearest multiple of 5.								
Alarm-1 Type	16 bit signed integer	51	<table border="1"> <thead> <tr> <th>Value</th> <th>Type</th> </tr> </thead> <tbody> <tr> <td>0</td> <td>None</td> </tr> <tr> <td>1</td> <td>Process Low</td> </tr> <tr> <td>2</td> <td>Process High</td> </tr> </tbody> </table>	Value	Type	0	None	1	Process Low	2	Process High
Value	Type										
0	None										
1	Process Low										
2	Process High										
Alarm-2 Type	16 bit signed integer	56									
Alarm-1 SP	16 bit signed integer	42	<i>Resolution Based Parameter : Refer Appendix-A</i>								
Alarm-1 Hysteresis	16 bit signed integer	52									
Alarm-2 SP	16 bit signed integer	43									
Alarm-2 Hysteresis	16 bit signed integer	57									
Alarm-1 Inhibit	16 bit signed integer	53	<table border="1"> <thead> <tr> <th>Value</th> <th>Inhibit</th> </tr> </thead> <tbody> <tr> <td>0</td> <td>No</td> </tr> <tr> <td>1</td> <td>Yes</td> </tr> </tbody> </table>	Value	Inhibit	0	No	1	Yes		
Value	Inhibit										
0	No										
1	Yes										
Alarm-2 Inhibit	16 bit signed integer	58									
Alarm-1 Logic	16 bit signed integer	54	<table border="1"> <thead> <tr> <th>Value</th> <th>Logic</th> </tr> </thead> <tbody> <tr> <td>0</td> <td>Normal</td> </tr> <tr> <td>1</td> <td>Reverse</td> </tr> </tbody> </table>	Value	Logic	0	Normal	1	Reverse		
Value	Logic										
0	Normal										
1	Reverse										
Alarm-2 Logic	16 bit signed integer	59									
Alarm-1 Latch	16 bit signed integer	55	<table border="1"> <thead> <tr> <th>Value</th> <th>Latch</th> </tr> </thead> <tbody> <tr> <td>0</td> <td>No</td> </tr> <tr> <td>1</td> <td>Yes</td> </tr> </tbody> </table>	Value	Latch	0	No	1	Yes		
Value	Latch										
0	No										
1	Yes										
Alarm-2 Latch	16 bit signed integer	60									

Parameter	Data Type	Address	Remark										
Retransmission Signal Type (Output-1)	16 bit signed integer	61	<table border="1"> <thead> <tr> <th>Value</th> <th>Signal Type</th> </tr> </thead> <tbody> <tr> <td>0</td> <td>0 to 20 mA</td> </tr> <tr> <td>1</td> <td>4 to 20 mA</td> </tr> <tr> <td>2</td> <td>0 to 5 V</td> </tr> <tr> <td>3</td> <td>0 to 10 V</td> </tr> </tbody> </table>	Value	Signal Type	0	0 to 20 mA	1	4 to 20 mA	2	0 to 5 V	3	0 to 10 V
Value	Signal Type												
0	0 to 20 mA												
1	4 to 20 mA												
2	0 to 5 V												
3	0 to 10 V												
Retransmission Low	16 bit signed integer	62	<i>Resolution Based Parameter : Refer Appendix-A</i>										
Retransmission High	16 bit signed integer	63											
Min / Max Process Value Reset Command	16 bit signed integer	40	<table border="1"> <thead> <tr> <th>Value</th> <th>Command</th> </tr> </thead> <tbody> <tr> <td>0</td> <td>—</td> </tr> <tr> <td>1</td> <td>Reset</td> </tr> </tbody> </table>	Value	Command	0	—	1	Reset				
Value	Command												
0	—												
1	Reset												
Alarm Latch Acknowledge Command	16 bit signed integer	41	<table border="1"> <thead> <tr> <th>Value</th> <th>Command</th> </tr> </thead> <tbody> <tr> <td>0</td> <td>—</td> </tr> <tr> <td>1</td> <td>ACK</td> </tr> </tbody> </table>	Value	Command	0	—	1	ACK				
Value	Command												
0	—												
1	ACK												
Linearization	16 bit signed integer	201	<table border="1"> <thead> <tr> <th>Value</th> <th>Feature</th> </tr> </thead> <tbody> <tr> <td>0</td> <td>Disable</td> </tr> <tr> <td>1</td> <td>Enable</td> </tr> </tbody> </table>	Value	Feature	0	Disable	1	Enable				
Value	Feature												
0	Disable												
1	Enable												
Linearization No. of Ponits	16 bit signed integer	202	—										
X-Co-ordinates	16 bit signed integer	203 to 234 X1 to X32	<i>Resolution Based Parameter : Refer Appendix-A</i>										
Y-Co-ordinates	16 bit signed integer	235 to 266 Y1 to Y32											



APPENDIX - A

HANDLING DECIMAL VALUES IN MODBUS REGISTERS

Overview

MODBUS protocol utilizes 16-bit signed integer registers (Input and Holding Registers) to store data. These registers accommodate values within the range -32,767 to 32,768. However, many process parameters require values with decimal precision. Since MODBUS registers inherently do not support floating-point values, decimal handling is achieved through scaling techniques.

This section describes how **Fixed** and **Programmable** decimal point parameters are stored and retrieved using MODBUS registers.

Handling Fixed Decimal Point Values

For parameters with a fixed decimal resolution, the integer values written to the MODBUS register are automatically converted by the device. However, when reading values, users must convert the retrieved integer values back to their corresponding decimal representations by dividing them by the appropriate power of 10.

Example: Fixed Decimal Resolution of 0.01

- Parameter Range: -12.34 to 20.00
- Scaling Factor: 100 (since $0.01 = 10^{(-2)}$)
- Writing a Value: To set a parameter to 34.82, write $34.82 \times 100 = 3482$ into the register.
- Reading a Value: If the register contains 3482, the actual value is $3482 \div 100 = 34.82$.

This method ensures consistency in handling values with fixed decimal precision across MODBUS communication.

Handling Programmable Decimal Point Values

For parameters with a programmable decimal resolution, the number of decimal places is stored in a separate parameter named Resolution (or PV Resolution). The resolution value determines the scaling factor applied when storing and retrieving values in MODBUS registers.

Resolution Parameter Definition

The resolution parameter is stored as an integer value corresponding to the decimal precision:

Resolution Value	Decimal Precision	Scaling Factor
0	1 (No Decimals)	$10^0=1$
1	0.1	$10^1=10$
2	0.01	$10^2=100$
3	0.001	$10^3=1000$

Example: Programmable Decimal Resolution

- Resolution Parameter Value: 3 (corresponding to 0.001 resolution)
- Writing a Value: To set the parameter to 27.651, use Scaling Factor 1000 (corresponding to Resolution value 3) to convert the decimal value to integer value : $27.651 \times 1000 = 27651$ and write to the MODBUS register.
- Reading a Value: If the register contains 27651, divide by 1000 (10^3) to get 27.651.

Using this method, MODBUS allows flexible handling of parameters where decimal precision may need to be adjusted dynamically.



APPENDIX - B

DC LINEAR SIGNAL INTERFACE

Overview

Various transmitters generate different signal types, such as mV, V, or mA, with distinct signal ranges. To ensure compatibility with a wide range of transmitters, PPI products offer configurable Signal Type and Range settings.

Common industry-standard signal ranges include:

- 0 to 80 mV, 0 to 160 mV
- 0 to 5 V, 1 to 5 V, 0 to 10 V
- 0 to 20 mA, 4 to 20 mA

Additionally, since transmitters output different signal ranges corresponding to specific process values (e.g., a 1 to 4.5 V signal may represent 5% to 95% RH), PPI products allow users to configure the process value range and resolution.

Required Parameters for Linear Transmitter Interface

For interfacing linear transmitters, the following six parameters must be configured:

Parameter	Definition	Example
Input Type	Defines the standard DC signal type in which the transmitter signal range falls.	4 to 20 mA
Signal Low	The minimum signal value corresponding to the lowest process value.	4.00 mA
Signal High	The maximum signal value corresponding to the highest process value.	20.00 mA
PV Resolution	Defines the smallest measurable unit for the process value.	0.01 psi
Range Low	The process value corresponding to Signal Low.	0.00 psi
Range High	The process value corresponding to Signal High.	5.00 psi

Mathematical Representation

The relationship between transmitter signal values and the corresponding process values follows a straight-line equation:

$$Y = mX + C$$

Where;

- X : Signal Value from Transmitter
- Y : Process Value Corresponding to X
- C : Process Value Corresponding to X = 0 (Y-intercept)
- m : Slope (Change in Process Value per unit Change in Signal Value)

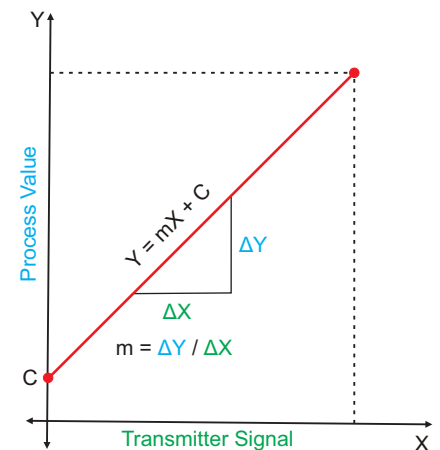

Examples of Transmitter Configurations

Example 1:

Pressure Transmitter (4 to 20 mA corresponding to 0 to 5 psi)

Input Type : 4-20 mA
 Signal Low : 4.00 mA
 Signal High : 20.00 mA
 PV Resolution : 0.01
 Range Low : 0.00
 Range High : 5.00

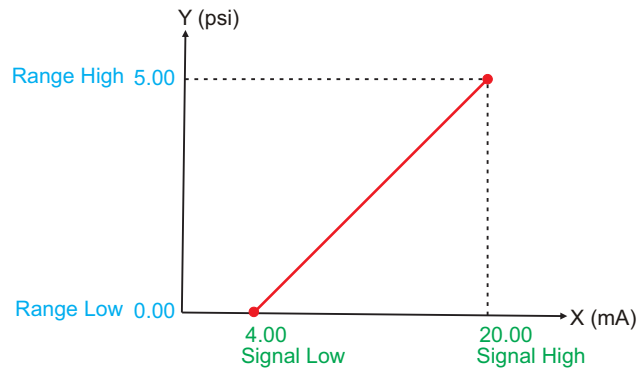

Example 2

Humidity Transmitter (1 to 4.5 V corresponding to 5 to 95 %RH)

Input Type : 0-5 V
 Signal Low : 1.000 V
 Signal High : 4.500 V
 PV Resolution : 0.1
 Range Low : 5.0
 Range High : 95.0

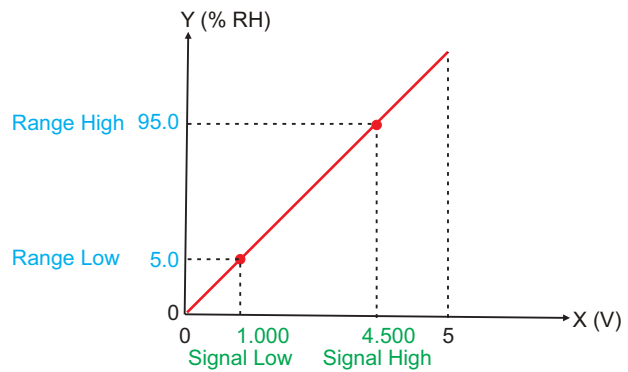

Example 3

Temperature Transmitter (0 to 20 mA corresponding to -50 to 250 °C)

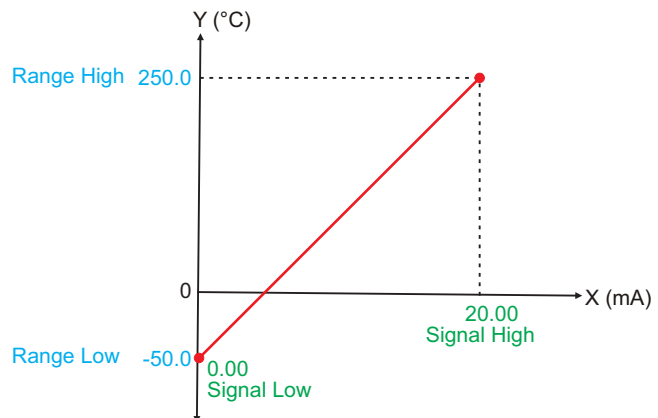

Input Type : 0-20 mA
 Signal Low : 0.00 mA
 Signal High : 20.00 mA
 PV Resolution : 0.1
 Range Low : -50.0
 Range High : 250.0



Process Precision Instruments (An ISO 9001 : 2008 Company)

 101, Diamond Industrial Estate, Navghar, Vasai Road (E), Dist. Palghar - 401210, Maharashtra, India

 Sales : 8208199048 / 8208141446 Support : 07498799226 / 08767395333

 sales@ppiindia.net  www.ppiindia.net