

# 4-Digit Economic Universal Process Indicator



## UPI-4D

Universal Input with inbuilt 24 VDC Transmitter Supply  
2 x Alarm Outputs & Retransmission Analog Output  
RS485 MODBUS RTU Serial Port  
1/8 DIN (48x96) Size

**Process Precision Instruments**  
Vasai Road (E), Dist. Palghar - 401210,  
Maharashtra, India

[www.ppiindia.net](http://www.ppiindia.net)

# User Manual



## CONTENTS

<b>1. FRONT PANEL LAYOUT</b>	<b>1</b>
<b>2. BASIC OPERATION</b>	<b>3</b>
<b>3. SET-UP MODE ACCESS AND OPERATION</b>	<b>5</b>
<b>4. ALARM PARAMETERS : PAGE-10</b>	<b>7</b>
<b>5. RETRANSMISSION PARAMETERS : PAGE-11</b>	<b>9</b>
<b>6. INPUT CONFIGURATION : PAGE-12</b>	<b>10</b>
<b>7. SUPERVISORY PARAMETERS : PAGE-13</b>	<b>13</b>
<b>8. ALARM ACKNOWLEDGE PARAMETER : PAGE-2</b>	<b>14</b>
<b>9. MECHANICAL INSTALLATION</b>	<b>15</b>
<b>10. ELECTRICAL CONNECTIONS</b>	<b>17</b>
<b>11. MODBUS MAPPING</b>	<b>21</b>
<b>APPENDIX-A : HANDLING DECIMAL VALUES IN MODBUS REGISTERS</b>	<b>25</b>
<b>APPENDIX-B : DC LINEAR SIGNAL INTERFACE</b>	<b>27</b>
<b>VERSION HISTORY</b>	<b>29</b>

## Section 1 FRONT PANEL LAYOUT

The indicator front panel comprises of digital readouts, LED indicators and tactile keys as shown in Figure 1.1 below.

*Figure 1.1*

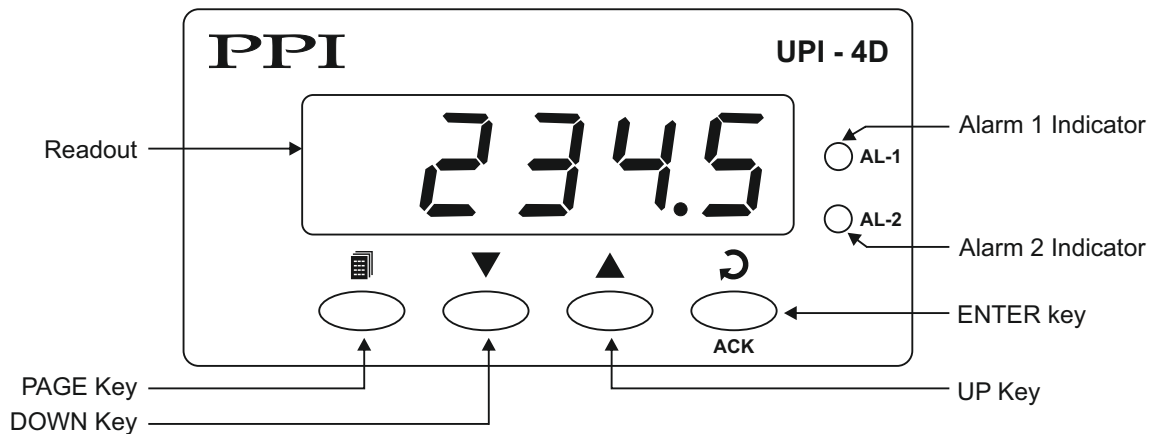

### READOUTS

The Readout is a 4 digit, 7-segment bright red LED display and usually displays the PV (Process Value). In Set-up Mode, the Readout displays parameter prompts and values/options, alternatively.

### INDICATORS

The front panel comprises 2 LED indicators that show Alarm status. Refer Table 1.1 below for details.





*Table 1.1*

LED	Status
AL1	Flashes while Alarm-1 is active.
AL2	Flashes while Alarm-2 is active.

## KEYS

There are four tactile keys provided on the front panel for configuring the indicator, setting-up the parameter values. Refer Table 1.2 below.

**Table 1.2**

Symbol	Key	Function
	PAGE	Press to enter / exit Set-up mode.
	DOWN	Press to decrease the parameter value. Pressing once decreases the value by one count; holding the key pressed speeds up the change.
	UP	Press to increase the parameter value. Pressing once increases the value by one count; holding the key pressed speeds up the change.
<b>ACK</b> 	ENTER	<p>If Readout is showing Parameter Name in the setup mode then upon pressing this key the Readout shows the value for the parameter.</p> <p>If Readout is showing Parameter Value in the setup mode then upon pressing this key the set parameter value is stored and the Readout shows the next Parameter Name.</p> <p><b>Note</b> : While in Main mode, this key can be used to acknowledge any pending Alarm(s) to de-activate alarm relay(s).</p>



## Section 2 BASIC OPERATION

### POWER UP

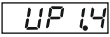
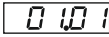
Upon switching on the power to the indicator, all displays are lit on for approximately 3 seconds. This is followed by the indication of the model name  and Version Number  for 1 second each.

### MAIN DISPLAY

After the Power-up display sequence, the Indicator enters MAIN Display Mode. The Readout shows the measured PV (Process Value).

### PV Error Indications

The process value is said to be in error if it exceeds the minimum / maximum range specified for the selected Input sensor type or if the sensor is disconnected (Open or Broken). The PV Error type, as shown in Table 2.1, is flashed on the Readout.

*Table 2.1*

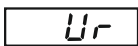
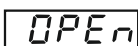
Message	Error Type	Cause
	Over-range	PV above Max. Range
	Under-range	PV below Min. Range
	Sensor Open	Thermocouple / RTD broken

### ALARM STATUS UNDER PV ERROR CONDITIONS

For Alarm activation, the under-range condition is treated as minimum PV, whereas the over-range and open conditions are treated as maximum PV. Thus, Process High alarm activates under *Over-range / Open error*. Similarly, Process Low alarm activates under *Under-range error*.

### Alarm Acknowledgment

While in Main mode, press ENTER Key to acknowledge any pending Alarm(s) to de-activate alarm relay(s).

### OPERATOR PAGE AND PARAMETERS

The parameters that require frequent settings are organized on a separate page, called the Operator Page. The availability of operator parameters is controlled at supervisory level and the parameter setting cannot be locked by the Master Lock.

### Accessing Operator Page & Adjusting Parameters

Step through the following sequence to open the operator page and to adjust the operator parameter values.

1. Press and release PAGE key. The Readout shows **PAGE**. Press and release ENTER key, the Readout shows page number **0**.
2. Press and release ENTER key. The Readout shows prompt for the first available operator parameter. Press and release ENTER key again. The Readout shows value for the first parameter.
3. Use UP / DOWN keys to adjust the value and then press ENTER key to store the set value and scroll to the next parameter.

The indicator cycles through parameters; after the last operator parameter, it loops back to the first. Press PAGE key to return to the MAIN Display Mode.

The operator parameters are described in Table 2.2. Note that the parameters presented on Operator Page depend upon the functions selected/enabled and supervisory level permissions. The operator parameter list mainly includes Setpoint Values for Alarm-1 and Alarm-2.

*Table 2.2*

Parameter Description	Settings (Default Value)
<p><b>ALARM-1 SETPOINT</b> <span style="float: right; border: 1px solid black; padding: 2px;">A 1.5P</span></p> <p>The setpoint for Alarm-1. This parameter is not available if the selected Alarm-1 type is 'None'.</p>	<p>Min to max Range specified for the selected Input Type (Default : Min or Max Range)</p>
<p><b>ALARM-2 SETPOINT</b> <span style="float: right; border: 1px solid black; padding: 2px;">A 2.5P</span></p> <p>The setpoint for Alarm-2. This parameter is not available if the selected Alarm-2 type is 'None'.</p>	<p>Min to max Range specified for the selected Input Type (Default : Min or Max Range)</p>



## Section 3

### SET-UP MODE : ACCESS AND OPERATION

The Indicator requires various user settings that determine how the indicator will function or operate. These settings are called Parameters.

For the convenience and ease of operation, the various parameters have been grouped separately depending upon the functions they define. Each such group is called a PAGE. Each PAGE is assigned a unique number, called PAGE NUMBER, for its access. The parameters contained in a PAGE are presented in a fixed sequence to the user for setting. The user can access a desired PAGE by entering its PAGE NUMBER and can select and set the desired parameter values.

#### PARAMETER NAMES

Each parameter has an identifying tag, called the Parameter Name. While setting parameter values in a PAGE, the Parameter Name precedes the Parameter Value.

While the readout shows Parameter Name, the UP / DOWN keys are non-functional. Upon pressing the ENTER key the readout shows the Parameter Value that can be adjusted using UP / DOWN keys.

#### ACCESSING A PAGE & ADJUSTING PARAMETER VALUES

Each PAGE is accessible only from the MAIN Display Mode. That is, from the current PAGE, the user must return to the MAIN Display Mode before the other PAGE can be accessed.

Step through the following sequence to open a desired PAGE and to adjust the parameter values.

1. Press and release PAGE key. The Readout shows **PAGE**.
2. Press and release ENTER key. The Readout shows **0**, the default page value.
3. Use UP/DOWN keys to set the desired PAGE NUMBER.
4. Press and release ENTER key. The Readout shows Name for the first available parameter under the selected page number.
5. Press and release ENTER key. The Readout shows value for the first parameter.
6. Go to step 8 if the value for first parameter is to be edited.
7. Press & release Enter Key until the readout shows the name for the desired parameter.
8. Use UP / DOWN keys to adjust the value and then press ENTER key to store the set value and scroll to the next parameter.
9. Go to step 7.

The indicator cycles through parameters; after the last parameter, it loops back to the first. Press PAGE to return to the MAIN Display Mode.

Figure 3.1 illustrates the example of altering the value for the parameter 'Input Type' from Type K Thermocouple to 4-20 mA.

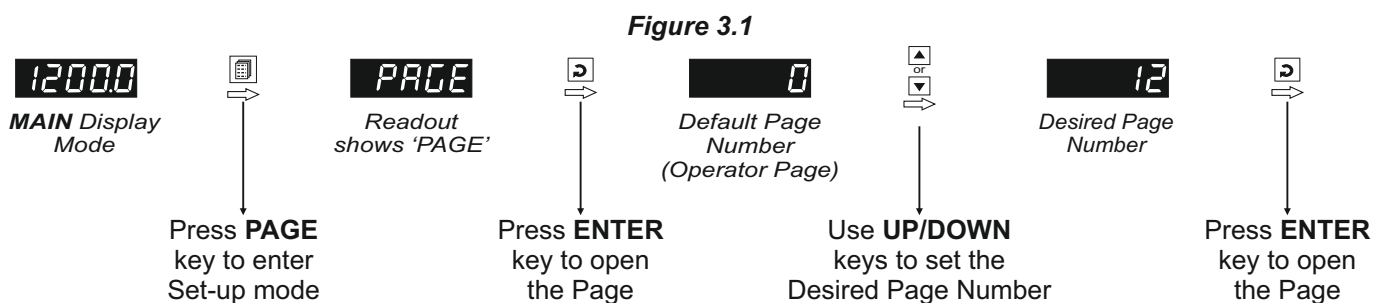

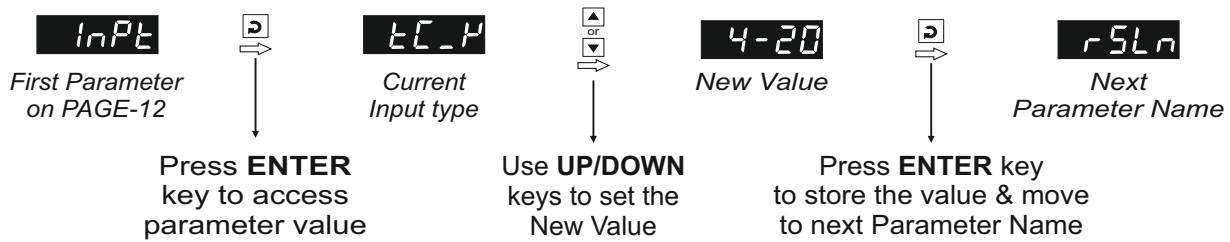

## Notes

1. Each page contains a fixed list of parameters that are presented in a pre-determined sequence. Note however that availability of a few parameters, called Conditional Parameters, depend upon the settings for some other parameters. For example, the parameter 'Alarm Setpoint' is **not available** if the corresponding 'Alarm type' is set to 'none'.
2. To exit the set-up mode and return to the MAIN Display Mode, press and release PAGE key.
3. If no key is pressed for approximately 30 seconds, the set-up mode times out and the indicator reverts to the MAIN Display Mode.

## MASTER LOCKING

The indicator facilitates locking all the PAGES (except Operator PAGE) by applying Master Lock Code. Under Locking, the parameters are available for *view only* and cannot be adjusted. The Master Lock, however, does not lock the operator parameters. This feature allows protecting the rather less frequently used parameters against any inadvertent changes while making the frequently used operator parameters still available for any editing.

For enabling / disabling the Lock, step through the following sequence:

### Locking

1. Press and release PAGE key while the indicator is in the MAIN Display Mode. The Readout shows **PAGE**.
2. Press and release ENTER key the Readout shows page number **0**
3. Use UP / DOWN keys to set the Page Number to 123 on the Readout.
4. Press and release ENTER key. The indicator returns to the MAIN Display Mode with the Lock enabled.

The Figure 3.2 below illustrates the Locking procedure.

Figure 3.2

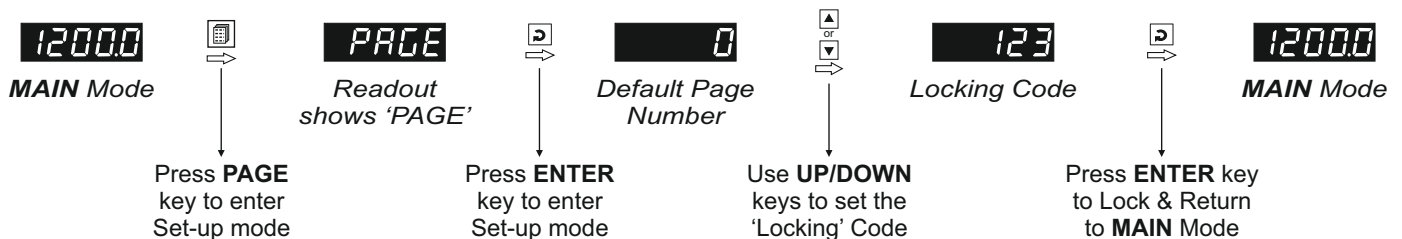

### UnLocking

Repeat the Locking procedure twice for unlocking.



## Section 4

### ALARM PARAMETERS : PAGE-10

Visit [www.ppiindia.net](http://www.ppiindia.net) for technical notes on ALARM for detailed understanding of the parameters / terminologies used for describing the Alarm parameters in this section.

The parameters required for configuring Alarms are grouped on PAGE-10. The configuration includes selecting the type of Alarm, setting the hysteresis value, enabling/disabling start-up Alarm suppression, etc. Refer Table 4.1 for parameter description & settings.

Table:4.1

Parameter Description	Settings (Default Value)
<b>ALARM-1 TYPE</b> <span style="border: 1px solid black; padding: 2px;">AL_1</span> Select the Alarm-1 activation type. Selecting 'None' will disable the alarm and suppress all the related parameters for Alarm-1.	<span style="border: 1px solid black; padding: 2px;">none</span> None <span style="border: 1px solid black; padding: 2px;">P_Lo</span> Process Low <span style="border: 1px solid black; padding: 2px;">P_Hi</span> Process High (Default : None)
<b>ALARM-1 SETPOINT</b> <span style="border: 1px solid black; padding: 2px;">A1SP</span> Sets the Process High or Process Low limit for Alarm-1.	Min. to Max. Range specified for the selected Input Type (Default : Min or Max Range)
<b>ALARM-1 HYSTERESIS</b> <span style="border: 1px solid black; padding: 2px;">A1HY</span> Sets differential (dead) band between Alarm-1 ON and OFF states.	<b>For DC Lin. Volts/Current</b> 1 to 9999 Counts <b>For Thermocouple/RTD</b> 1 to 999 or 0.1 to 999.9 (Default : 2.0)
<b>ALARM-1 INHIBIT</b> <span style="border: 1px solid black; padding: 2px;">A1IH</span> Set to Yes to suppress Alarm-1 activation upon power-up (process start-up) condition.	<span style="border: 1px solid black; padding: 2px;">no</span> No <span style="border: 1px solid black; padding: 2px;">YES</span> Yes (Default :No)
<b>ALARM-1 LOGIC</b> <span style="border: 1px solid black; padding: 2px;">A1LG</span> Select 'Normal' if Alarm-1 relay is to activate an Audio / Visual alarm. Select 'Reverse' for Tripping (cut-off) the system.	<span style="border: 1px solid black; padding: 2px;">norm</span> Normal <span style="border: 1px solid black; padding: 2px;">rev</span> Reverse (Default : Normal)
<b>ALARM-1 LATCH</b> <span style="border: 1px solid black; padding: 2px;">A1LE</span> No The Relay switches ON/OFF with Alarm switching.  Yes The Relay Output switches (ON for Normal Logic / OFF for Reverse Logic) upon Alarm activation. However, Alarm de-activation does not affect the Relay status. The Relay status can only be regained by pressing 'Acknowledge-key' provided the Alarm has de-activated.	<span style="border: 1px solid black; padding: 2px;">no</span> No <span style="border: 1px solid black; padding: 2px;">YES</span> Yes (Default :No)

# 4-Digit Economic Universal Process Indicator

Parameter Description	Settings (Default Value)
<p><b>ALARM-2 TYPE</b> <span style="float: right; border: 1px solid black; padding: 2px;">AL_2</span></p> <p>Select the Alarm-2 activation type. Selecting 'None' will disable the alarm and suppress all the related parameters for Alarm-2.</p>	<div style="display: flex; flex-direction: column; gap: 5px;"> <div style="display: flex; align-items: center;"> <div style="border: 1px solid black; padding: 2px; margin-right: 5px;">none</div> <span>None</span> </div> <div style="display: flex; align-items: center;"> <div style="border: 1px solid black; padding: 2px; margin-right: 5px;">P_Lo</div> <span>Process Low</span> </div> <div style="display: flex; align-items: center;"> <div style="border: 1px solid black; padding: 2px; margin-right: 5px;">P_Hi</div> <span>Process High</span> </div> </div> <p style="text-align: center;">(Default : None)</p>
<p><b>ALARM-2 SETPOINT</b> <span style="float: right; border: 1px solid black; padding: 2px;">A2SP</span></p> <p>Sets the Process High or Process Low limit for Alarm-2.</p>	<p>Min. to Max. Range specified for the selected Input Type</p> <p>(Default : Min/Max Range)</p>
<p><b>ALARM-2 HYSTERESIS</b> <span style="float: right; border: 1px solid black; padding: 2px;">A2HY</span></p> <p>Sets differential (dead) band between Alarm-2 ON and OFF states.</p>	<p><b>For DC Lin. Volts/Current</b> 1 to 9999 Counts</p> <p><b>For Thermocouple/RTD</b> 1 to 999 or 0.1 to 999.9</p> <p>(Default : 2.0)</p>
<p><b>ALARM-2 INHIBIT</b> <span style="float: right; border: 1px solid black; padding: 2px;">A2IH</span></p> <p>Set to Yes to suppress Alarm-2 activation upon power-up (process start-up) condition.</p>	<div style="display: flex; flex-direction: column; gap: 5px;"> <div style="display: flex; align-items: center;"> <div style="border: 1px solid black; padding: 2px; margin-right: 5px;">no</div> <span>No</span> </div> <div style="display: flex; align-items: center;"> <div style="border: 1px solid black; padding: 2px; margin-right: 5px;">YES</div> <span>Yes</span> </div> </div> <p style="text-align: center;">(Default :No)</p>
<p><b>ALARM-2 LOGIC</b> <span style="float: right; border: 1px solid black; padding: 2px;">A2LG</span></p> <p>Select 'Normal' if Alarm-2 relay is to activate an Audio / Visual alarm. Select 'Reverse' for tripping (cut-off) the system.</p>	<div style="display: flex; flex-direction: column; gap: 5px;"> <div style="display: flex; align-items: center;"> <div style="border: 1px solid black; padding: 2px; margin-right: 5px;">norm</div> <span>Normal</span> </div> <div style="display: flex; align-items: center;"> <div style="border: 1px solid black; padding: 2px; margin-right: 5px;">rev</div> <span>Reverse</span> </div> </div> <p style="text-align: center;">(Default : Normal)</p>
<p><b>ALARM-2 LATCH</b> <span style="float: right; border: 1px solid black; padding: 2px;">A2LT</span></p> <p>No The Relay switches ON/OFF with Alarm switching.</p> <p>Yes The Relay Output switches (ON for Normal Logic / OFF for Reverse Logic) upon Alarm activation. However, Alarm de-activation does not affect the Relay status. The Relay status can only be regained by pressing 'Acknowledge-key' provided the Alarm has de-activated.</p>	<div style="display: flex; flex-direction: column; gap: 5px;"> <div style="display: flex; align-items: center;"> <div style="border: 1px solid black; padding: 2px; margin-right: 5px;">no</div> <span>No</span> </div> <div style="display: flex; align-items: center;"> <div style="border: 1px solid black; padding: 2px; margin-right: 5px;">YES</div> <span>Yes</span> </div> </div> <p style="text-align: center;">(Default :No)</p>



## Section 5

### RETRANSMISSION PARAMETERS : PAGE-11

The parameters required for configuring *Retransmission* are grouped on PAGE-11. The configuration includes selecting the Output type, Recorder Low & High settings etc. Refer Table 5.1 for parameter description & settings.

**Table 5.1**

Parameter Description	Settings (Default Value)
<p><b>RETRANSMISSION (RECORDER) OUTPUT TYPE</b> <span style="border: 1px solid black; padding: 2px;">rECLo</span></p> <p>Select Output Signal type in accordance with the hardware module fitted. Select 0-20 or 4-20 mA, if Current output module is fitted. Select 0-5 or 0-10 V, if Voltage output module is fitted.</p>	<div style="display: flex; flex-direction: column; align-items: flex-start;"> <div style="margin-bottom: 5px;"><span style="border: 1px solid black; padding: 2px;">0-20</span> 0 to 20 mA</div> <div style="margin-bottom: 5px;"><span style="border: 1px solid black; padding: 2px;">4-20</span> 4 to 20 mA</div> <div style="margin-bottom: 5px;"><span style="border: 1px solid black; padding: 2px;">0-5</span> 0 to 5 Volts</div> <div style="margin-bottom: 5px;"><span style="border: 1px solid black; padding: 2px;">0-10</span> 0 to 10 Volts</div> <p>(Default : 0 to 20 mA)</p> </div>
<p><b>RETRANSMISSION (RECORDER) LOW</b> <span style="border: 1px solid black; padding: 2px;">rECL</span></p> <p>Set the minimum Process Value (<b>PV</b>) that shall correspond to the minimum recorder output signal level (0mA or 4mA or 0V).</p>	<p>Min. to Max. Range specified for the selected Input Type (Default : -199)</p>
<p><b>RETRANSMISSION (RECORDER) HIGH</b> <span style="border: 1px solid black; padding: 2px;">rECH</span></p> <p>Set the maximum Process Value (<b>PV</b>) that shall correspond to the maximum recorder output signal level (20 mA or 10 V or 5 V).</p>	<p>Min. to Max. Range specified for the selected Input Type (Default : 1376)</p>



## Section 6







### INPUT CONFIGURATION PARAMETERS : PAGE-12

Table 6.1

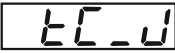
Parameter Description	Settings (Default Value)																								
<b>INPUT TYPE</b> <span style="border: 1px solid black; padding: 2px;">InPt</span> Select Input type in accordance with the type of Thermocouple or RTD sensor or transducer output connected for process value measurement.	Refer Table 6.2 (Default : Type K)																								
<b>RESOLUTION</b> <span style="border: 1px solid black; padding: 2px;">r5Ln</span> Set the process value indication resolution (decimal point). All the resolution based parameters (hysteresis, alarm setpoints etc.) then follow this resolution setting.	Refer Table 6.2 (Default : 1°C)																								
<b>UNITS</b> <span style="border: 1px solid black; padding: 2px;">Unit</span> (Applicable for Thermocouple & RTD Pt100 Input only) Select Temperature units in °C or °F.	<div style="display: flex; flex-direction: column; align-items: center;"> <div style="border: 1px solid black; padding: 2px; margin-bottom: 5px;">°C</div> <div style="border: 1px solid black; padding: 2px; margin-bottom: 5px;">°F</div> </div> (Default : °C)																								
<b>DC SIGNAL LOW</b> <span style="border: 1px solid black; padding: 2px;">50.L0</span> (Available for DC Linear Input) This parameter is the transmitter output signal value that corresponds to the Range Low process value. Refer <i>Appendix-B : DC Linear Signal Interface</i> for details.	<table border="1"> <thead> <tr> <th>Input Type</th> <th>Settings</th> <th>Default</th> </tr> </thead> <tbody> <tr><td>0 to 20 mA</td><td>0.00 to Signal High</td><td>0.00</td></tr> <tr><td>4 to 20 mA</td><td>4.00 to Signal High</td><td>4.00</td></tr> <tr><td>0 to 80 mV</td><td>0.00 to Signal High</td><td>0.00</td></tr> <tr><td>0 to 1.25 V</td><td>0.000 to Signal High</td><td>0.000</td></tr> <tr><td>0 to 5 V</td><td>0.000 to Signal High</td><td>0.000</td></tr> <tr><td>0 to 10 V</td><td>0.00 to Signal High</td><td>0.00</td></tr> <tr><td>1 to 5 V</td><td>1.000 to Signal High</td><td>1.000</td></tr> </tbody> </table>	Input Type	Settings	Default	0 to 20 mA	0.00 to Signal High	0.00	4 to 20 mA	4.00 to Signal High	4.00	0 to 80 mV	0.00 to Signal High	0.00	0 to 1.25 V	0.000 to Signal High	0.000	0 to 5 V	0.000 to Signal High	0.000	0 to 10 V	0.00 to Signal High	0.00	1 to 5 V	1.000 to Signal High	1.000
Input Type	Settings	Default																							
0 to 20 mA	0.00 to Signal High	0.00																							
4 to 20 mA	4.00 to Signal High	4.00																							
0 to 80 mV	0.00 to Signal High	0.00																							
0 to 1.25 V	0.000 to Signal High	0.000																							
0 to 5 V	0.000 to Signal High	0.000																							
0 to 10 V	0.00 to Signal High	0.00																							
1 to 5 V	1.000 to Signal High	1.000																							
<b>DC SIGNAL HIGH</b> <span style="border: 1px solid black; padding: 2px;">50.H1</span> (Available for DC Linear Input) This parameter is the transmitter output signal value that corresponds to the Range High process value. Refer <i>Appendix-B : DC Linear Signal Interface</i> for details.	<table border="1"> <thead> <tr> <th>Input Type</th> <th>Settings</th> <th>Default</th> </tr> </thead> <tbody> <tr><td>0 to 20 mA</td><td>Signal Low to 20.00</td><td>20.00</td></tr> <tr><td>4 to 20 mA</td><td>Signal Low to 20.00</td><td>20.00</td></tr> <tr><td>0 to 80 mV</td><td>Signal Low to 80.00</td><td>80.00</td></tr> <tr><td>0 to 1.25 V</td><td>Signal Low to 1.250</td><td>1.250</td></tr> <tr><td>0 to 5 V</td><td>Signal Low to 5.000</td><td>5.000</td></tr> <tr><td>0 to 10 V</td><td>Signal Low to 10.00</td><td>10.00</td></tr> <tr><td>1 to 5 V</td><td>Signal Low to 5.000</td><td>5.000</td></tr> </tbody> </table>	Input Type	Settings	Default	0 to 20 mA	Signal Low to 20.00	20.00	4 to 20 mA	Signal Low to 20.00	20.00	0 to 80 mV	Signal Low to 80.00	80.00	0 to 1.25 V	Signal Low to 1.250	1.250	0 to 5 V	Signal Low to 5.000	5.000	0 to 10 V	Signal Low to 10.00	10.00	1 to 5 V	Signal Low to 5.000	5.000
Input Type	Settings	Default																							
0 to 20 mA	Signal Low to 20.00	20.00																							
4 to 20 mA	Signal Low to 20.00	20.00																							
0 to 80 mV	Signal Low to 80.00	80.00																							
0 to 1.25 V	Signal Low to 1.250	1.250																							
0 to 5 V	Signal Low to 5.000	5.000																							
0 to 10 V	Signal Low to 10.00	10.00																							
1 to 5 V	Signal Low to 5.000	5.000																							
<b>DC RANGE LOW</b> <span style="border: 1px solid black; padding: 2px;">r.L0</span> (Available for DC Linear Input) Sets process value corresponding to minimum DC Linear signal input (e.g., 0V, 0mA, 4mA, etc.). Refer <i>Appendix-B : DC Linear Signal Interface</i> for details.	-1999 to 9999 Counts (Default : 0)																								

Parameter Description	Settings (Default Value)
<p><b>DC RANGE HIGH</b> <span style="border: 1px solid black; padding: 2px;">r.HI</span></p> <p><i>(Available for DC Linear Input)</i></p> <p>Sets process value corresponding to maximum DC Linear signal input (e.g., 5V, 10V, 20mA, etc.). Refer <i>Appendix-B : DC Linear Signal Interface</i> for details.</p>	<p>-1999 to 9999 Counts (Default : 1000)</p>
<p><b>OFFSET</b> <span style="border: 1px solid black; padding: 2px;">OFFSE</span></p> <p>This value is algebraically added to the measured PV to derive the final PV that is displayed and used for Alarm / Retransmission.</p> <p>Final PV = Measured PV + Offset</p>	<p><b>For DC Linear Volts/Current</b> -1999 to 9999 Counts <b>For Thermocouple/RTD</b> -199 to 999 or -199.9 to 999.9 (Default : 0)</p>
<p><b>DIGITAL FILTER</b> <span style="border: 1px solid black; padding: 2px;">FILT</span></p> <p>Sets the time constant, in seconds, for the low-pass digital filter applied to the measured PV. The filter helps smoothing / averaging the signal input and removing the undesired noise. The higher the filter value the lower the indication response to the PV changes and vice-a-versa.</p> <p><b>Setting the value to 0.0 disables the filter.</b></p>	<p>0.0 to 60.0 Seconds (Default : 2.0 sec.)</p>

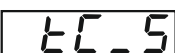
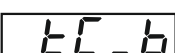
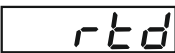
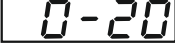
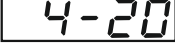
**Table 6.2**

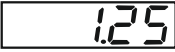
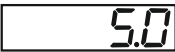
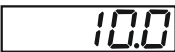
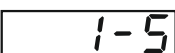
Option	What it means	Range (Min. to Max.)	Resolution
	Type J Thermocouple	0.0 to +960.0°C / +32.0 to +1760.0°F	1 °C/°F
	Type K Thermocouple	-200.0 to +1376.0°C / -328.0 to +2508.0°F	
	Type T Thermocouple	-200.0 to +387.0°C / -328.0 to +728.0°F	
	Type R Thermocouple	0.0 to +1771.0°C / +32.0 to +3219.0°F	
	Type S Thermocouple	0.0 to +1768.0°C / +32.0 to +3214.0°F	
	Type B Thermocouple	0.0 to +1826.0°C / +32.0 to +3318.0°F	
	3-wire, RTD Pt100	-199.9 to +600.0°C / -328.0 to +1112.0°F	1 °C/°F or 0.1 °C/°F
	0 to 20mA DC current	-1999 to 9999 units	1 0.1 0.01 0.001 units
	4 to 20mA DC current		
	0 to 80mV DC voltage		
	0 to 1.25V DC voltage		
	0 to 5.0V DC voltage		
	0 to 10.0V DC voltage		
	1 to 5.0V DC voltage		



Section 7

**SUPERVISORY PARAMETERS : PAGE-13**

Table 7.1

Parameter Description	Settings (Default Value)
<b>ALARM SP ADJUSTMENT ON OPERATOR PAGE</b> <span style="float: right;">ALSP</span> Supervisory permission for Alarm setpoint adjustments on Operator Page. Set to 'Enable' for permission.	<span style="float: right;">d5bL</span> Disable <span style="float: right;">EnbL</span> Enable (Default : Disable)
<b>FRONT PANEL ALARM ACKNOWLEDGE</b> <span style="float: right;">RACP</span> This parameter determines whether the front panel ENTER key can be used as Alarm Acknowledge.	<span style="float: right;">d5bL</span> Disable <span style="float: right;">EnbL</span> Enable (Default : Enable)
<b>RECORDER</b> <span style="float: right;">rEC</span> Supervisory permission for enabling recorder (retransmission) output.	<span style="float: right;">d5bL</span> Disable <span style="float: right;">EnbL</span> Enable (Default : Disable)
<b>BAUD RATE</b> <span style="float: right;">bAUD</span> Communication speed in 'Bits per Second'. Set the value to match with the host baud rate.	<span style="float: right;">4.8</span> 4800 <span style="float: right;">9.6</span> 9600 <span style="float: right;">19.2</span> 19200 (Default : 9.6)
<b>PARITY</b> <span style="float: right;">PAR</span> One of the communication error trapping features. Select the data packet parity as implemented by the host protocol.	<span style="float: right;">nonE</span> None <span style="float: right;">EuEn</span> Even <span style="float: right;">Odd</span> Odd (Default : Even)
<b>SERIAL ID NUMBER</b> <span style="float: right;">Id</span> Unique numeric code assigned to the indicator for identification by the host. Set the value as required by the host.	1 to 127 (Default : 1)
<b>SERIAL WRITE PERMISSION</b> <span style="float: right;">CoñE</span> Setting to 'No' disallows the host to set / modify any parameter value. The host, however, can read the value.	<span style="float: right;">no</span> No <span style="float: right;">YES</span> Yes (Default : Yes)



Section 8  
ALARM ACK PARAMETER : PAGE-2

Table 8.1

Parameter Description	Settings (Default Value)
<p><b>ALARM ACKNOWLEDGE</b> <span style="border: 1px solid black; padding: 2px;">ALP</span></p> <p>Set to Yes to acknowledge one or more active alarms. Acknowledging the alarm de-activates (mutes) the associated relay output (buzzer), however, the front panel LED indication is unaffected.</p>	<p><span style="border: 1px solid black; padding: 2px;">no</span> No</p> <p><span style="border: 1px solid black; padding: 2px;">YES</span> Yes</p> <p>(Default :No)</p>



## Section 9 MECHANICAL INSTALLATION

The following precautions should be strictly observed while installing the indicator:

1. The place of installation should be free of corrosive/combustible gases and electrically conductive pollution.
2. Ensure that the place of installation is not subject to rapid ambient changes that can cause condensation. Also the Ambient Temperature and Relative Humidity surrounding the indicator should not exceed the maximum specified for the proper operation of the Indicator.
3. The place of installation should be adequately protected against excessive electrostatic or electromagnetic interference.
4. The Indicator should not be subject to direct vibration or shock.
5. The Indicator should not be exposed to dust, salt air, direct sunlight or radiant heat.

### OUTER DIMENSIONS

The Figure 9.1 show the outer dimensions, respectively.

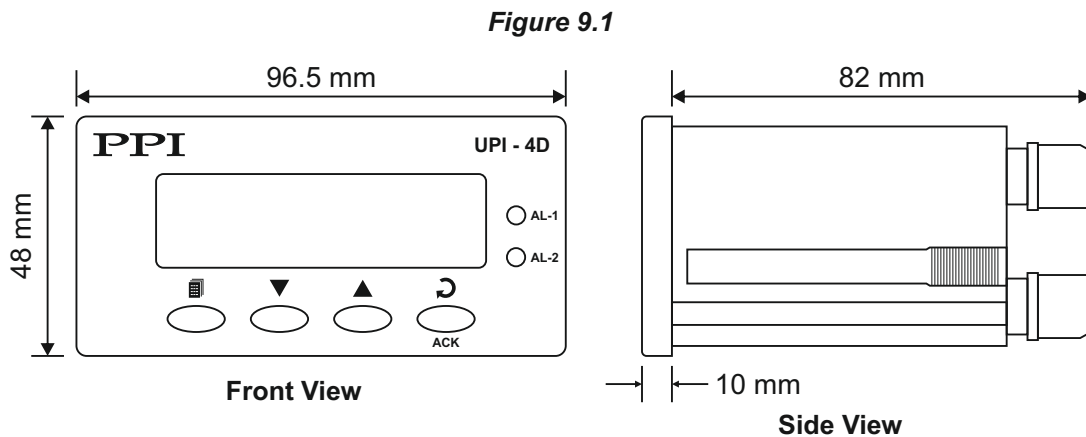

### PANEL CUTOUT AND RECOMMENDED MINIMUM SPACING

The Figure 9.2 shows panel cutout requirements for a single Indicator and also the minimum spacing recommended if several Indicators are required to be mounted on a single panel.

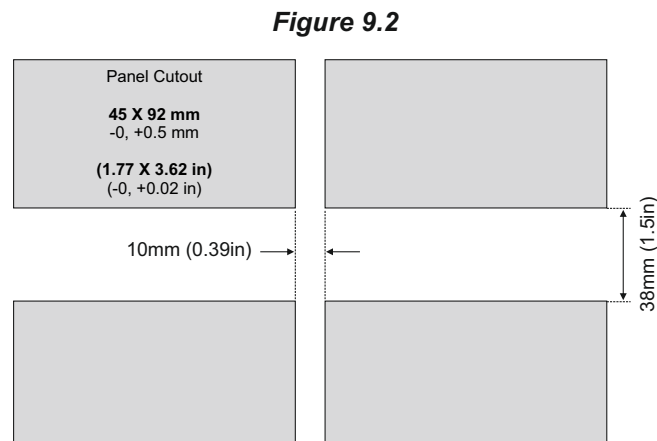

## PANEL MOUNTING

Follow the steps below for mounting the Indicator on panel:

1. Prepare a rectangular cutout to the size shown in Figure 9.2.
2. Remove the Panel Mounting Clamp from the Indicator Enclosure.
3. Insert the rear of the Indicator housing through the panel cutout from the front of the mounting panel.
4. Hold the Indicator gently against the mounting panel such that it positions correctly against the panel wall, see Figure 9.3. Apply pressure only on the bezel and not on the front label.
5. Insert the clamps on either side of the enclosure in the grooves provided and slide them forward until they are firmly in contact with the rear face of the mounting panel. Refer Figure 9.3 below.

**Figure 9.3**

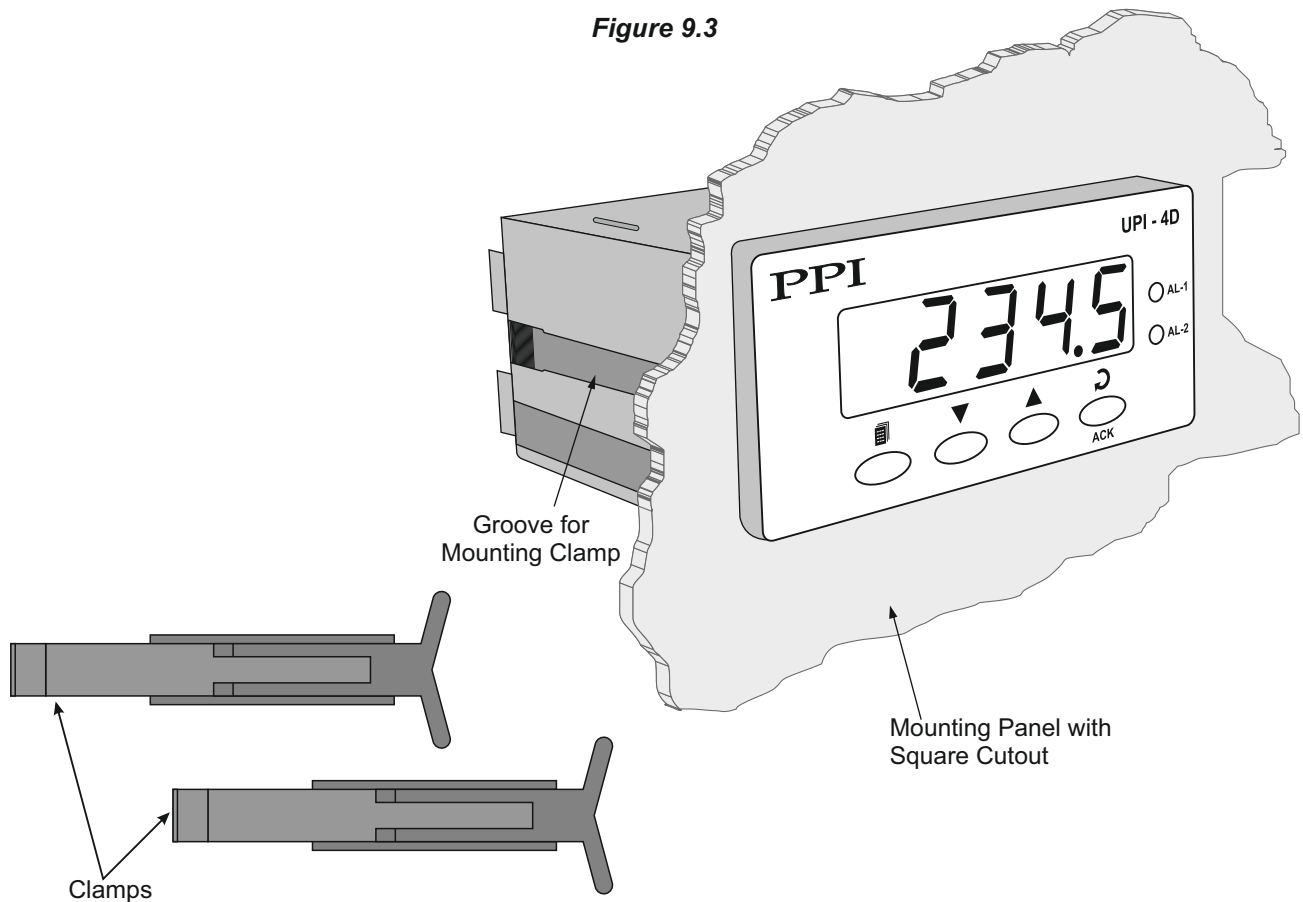

## Section 10 ELECTRICAL CONNECTIONS

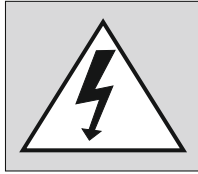

**WARNING**  
MISHANDLING / NEGLIGENCE CAN  
RESULT IN PERSONAL DEATH OR  
SERIOUS INJURY.

1. The user must rigidly observe the Local Electrical Regulations.
2. Do not make any connections to the unused terminals for making a tie-point for other wires (or for any other reasons) as they may have some internal connections. Failing to observe this may result in permanent damage to the indicator.
3. Run power supply cables separated from the low-level signal cables (like Thermocouple, RTD, DC Linear Current/Voltage, etc.). If the cables are run through conduits, use separate conduits for power supply cable and low-level signal cables.
4. Use appropriate fuses and switches, wherever necessary, for driving the high voltage loads to protect the indicator from any possible damage due to high voltage surges of extended duration or short-circuits on loads.
5. Take care not to over-tighten the terminal screws while making connections.
6. Make sure that the Indicator supply is switched-off while making/removing any connections or removing the Indicator from its enclosure.

### CONNECTION DIAGRAM

The Electrical Connection Diagram is shown on the top side of the Indicator enclosure. The diagram shows the terminals viewed from the REAR SIDE with the Indicator label upright. Refer the label provided on the Rear Side for terminal numbers. Note that a few connections are functional / applicable only if the respective plug-in modules are fitted.

The rear panel electrical wiring connection diagram is shown in Figure 10.1 below.

*Figure 10.1*

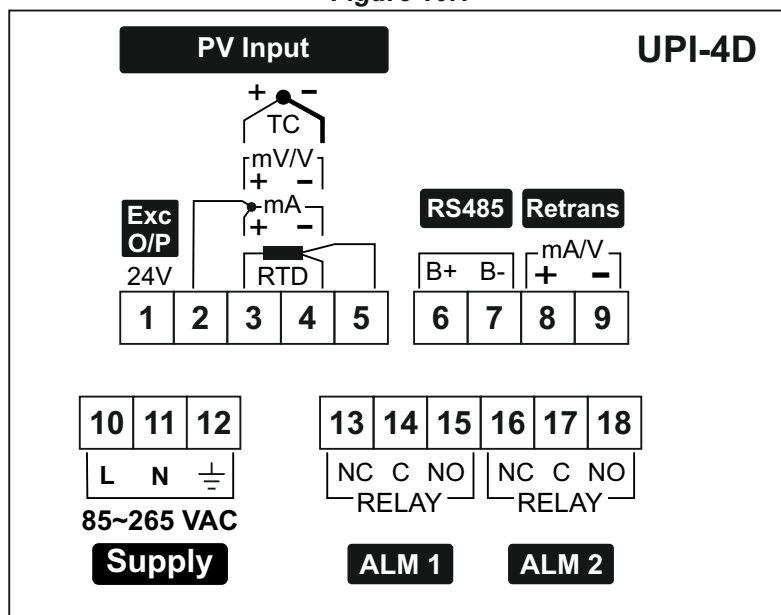

## DESCRIPTIONS

The back panel connections are described as under:

### EXC O/P (24 V Excitation Voltage)

As standard the indicator is supplied with 24 VDC @ 30 mA power source. This is primarily meant for exciting 2-wire or 4-wire current output transmitters. Only Single terminal (1) is provided for 24V DC excitation supply. The following figures illustrate a few connection examples.

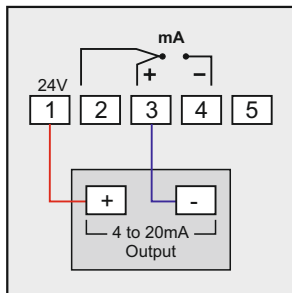

2-wire Current Transmitter

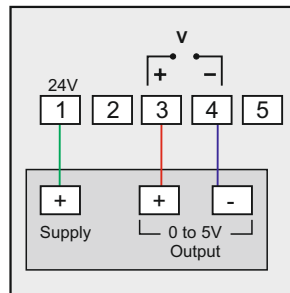

3-wire Voltage Transmitter

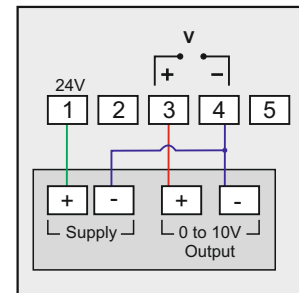

4-wire Voltage Transmitter

### PV INPUT

The Indicator accepts Thermocouples (J, K, T, R, S, B), 3-wire RTD Pt100 and DC Linear Current/Voltage (mA/mV/V) as input. Refer Figures 10.2 below.

#### Thermocouple

Connect Thermocouple Positive (+) to terminal 3 and Negative (-) to terminal 4 as shown in Figure 10.2. Use the correct type of Thermocouple extension lead wires or compensating cable for the entire distance ensuring the correct polarity throughout. Avoid joints in the cable.

#### RTD Pt100, 3-wire

Connect single lead end of RTD bulb to terminal 3 and the double lead ends to terminal 4 and 5 (interchangeable) as shown in Figure 10.2. Use copper conductor leads of very low resistance ensuring that all 3 leads are of the same gauge and length. Avoid joints in the cable.

#### DC Linear MilliVolts (mV)/Volts (V)

Use a shielded twisted pair with the shield grounded at the signal source for connecting mV source. Connect signal (+) to terminal 3 & common (-) to terminal 4, as shown in Figure 10.2.

#### DC Linear Current (mA)

Use a shielded twisted pair with the shield grounded at the signal source for connecting mA source. Connect signal (+) to terminal 3 & common (-) to terminal 4 and also *short terminals 2 & 3*, as shown in Figure 10.2.

Figure 10.2

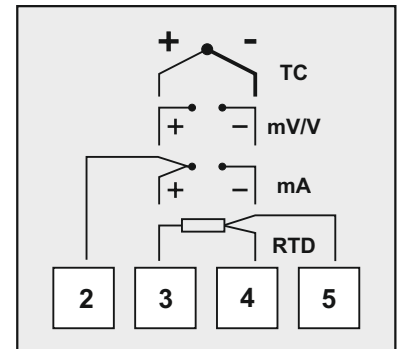

## RETRANSMISSION OUTPUT

The retransmission output is either DC Current (0/4-20 mA) or DC Voltage (0-5/10 V) depending on the module fitted. The terminal labeled '+' & '-' are the Current/Voltage source output and return, respectively.

**Figure 10.3 : mA / V Output**

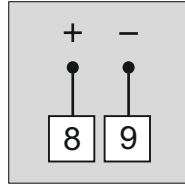

## ALARM-1 ALARM-2

The Alarm-1 & Alarm-2 are available in the form of Relay outputs as standard. The connection descriptions are shown in figures 10.4.

### Relay

Potential-free Relay changeover contacts N/O (Normally Open) and C (Common) rated 2A/240 VAC (resistive load) are provided as Relay output. Use external auxiliary device like contactor with appropriate contact rating for driving the actual load.

**Figure 10.4**

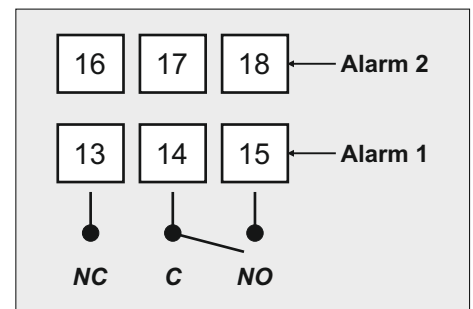

## SERIAL COMMUNICATION PORT

(Applicable if the Option plug-in module for RS485 Serial Port is fitted)

**Figure 10.5**

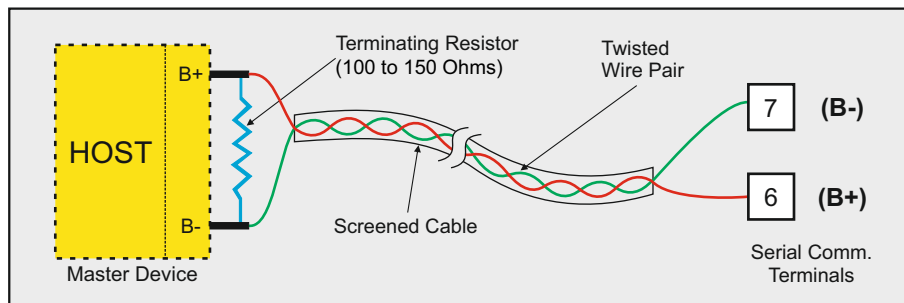

If the Optional plug-in communication board is fitted, connect terminals B+ and B- of the Indicator to the respective terminals of the Master device (PC/HMI). For reliable noise free communication, use a pair of twisted wires inside screened cable as shown in Figure 10.5. The wire should have less than 100 ohms/km nominal DC resistance (Typically 24 AWG or thicker). Connect the terminating resistor (Typically 100 to 150 ohm) at one end to improve noise immunity.

## POWER SUPPLY



The indicator is designed for installation in an enclosure which provides adequate protection against electric shock. Local regulations regarding electrical installation should be rigidly observed. Consideration should be given to prevention of access to the Power Supply terminals by unauthorized personnel.

**Figure 10.6**

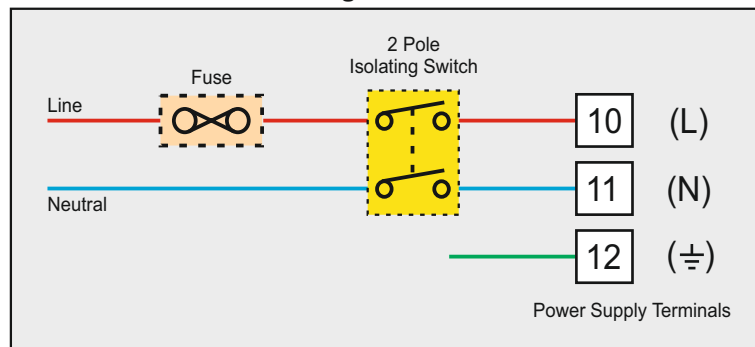

As standard, the indicator is supplied with power connections suited for 85 to 264 VAC. Use well-insulated copper conductor wire of the size not smaller than 0.5mm<sup>2</sup> for power supply connections ensuring proper polarity as shown in Figure 10.6. The indicator is not provided with fuse and power switch. If necessary, mount them separately. Use a time lag fuse rated 1A @ 240 VAC.



## Section 11 MODBUS MAPPING

Table 1 : Read Only Parameters

Parameter	Data Type	Address	Remark								
Parameter Modified through Front Panel Keys	16 bit signed integer	1	<table border="1"> <thead> <tr> <th>Value</th> <th>Meaning</th> </tr> </thead> <tbody> <tr> <td>1</td> <td>One or more parameters are modified using front panel keys since last MODBUS read.</td> </tr> <tr> <td>0</td> <td>No parameter is modified since last MODBUS read.</td> </tr> </tbody> </table>	Value	Meaning	1	One or more parameters are modified using front panel keys since last MODBUS read.	0	No parameter is modified since last MODBUS read.		
Value	Meaning										
1	One or more parameters are modified using front panel keys since last MODBUS read.										
0	No parameter is modified since last MODBUS read.										
Process Value (PV)	16 bit signed integer	2	<p><i>Resolution Based Parameter : Refer Appendix-A</i></p> <p>The following constant counts indicate PV Errors.</p> <table border="1"> <thead> <tr> <th>Value</th> <th>PV Error Type</th> </tr> </thead> <tbody> <tr> <td>-32768</td> <td>Under Range</td> </tr> <tr> <td>+32752</td> <td>Over Range</td> </tr> <tr> <td>+32767</td> <td>Sensor Open</td> </tr> </tbody> </table>	Value	PV Error Type	-32768	Under Range	+32752	Over Range	+32767	Sensor Open
Value	PV Error Type										
-32768	Under Range										
+32752	Over Range										
+32767	Sensor Open										
Ambient Temperature	16 bit signed integer	5	<p><i>Resolution Based Parameter : Refer Appendix-A</i></p> <p>The measured Ambient Temperature is used for thermocouple Cold-Junction Compensation.</p> <p>The value is always in °C with 0.1°C resolution.</p>								
Alarm 1 Status	16 bit signed integer	6	<table border="1"> <thead> <tr> <th>Value</th> <th>Status</th> </tr> </thead> <tbody> <tr> <td>0</td> <td>Alarm OFF (Inactive)</td> </tr> <tr> <td>1</td> <td>Alarm ON (Active)</td> </tr> </tbody> </table>	Value	Status	0	Alarm OFF (Inactive)	1	Alarm ON (Active)		
Value	Status										
0	Alarm OFF (Inactive)										
1	Alarm ON (Active)										
Alarm 2 Status	16 bit signed integer	7									

**Table 2 : Read / Write Parameters**

Parameter	Data Type	Address	Remark																																			
Input Type	16 bit signed integer	44	<table border="1"> <thead> <tr> <th>Value</th> <th>Type</th> </tr> </thead> <tbody> <tr><td>0</td><td>Type J Thermocouple</td></tr> <tr><td>1</td><td>Type K Thermocouple</td></tr> <tr><td>2</td><td>Type T Thermocouple</td></tr> <tr><td>3</td><td>Type R Thermocouple</td></tr> <tr><td>4</td><td>Type S Thermocouple</td></tr> <tr><td>5</td><td>Type B Thermocouple</td></tr> <tr><td>6</td><td rowspan="2">Reserved TC (Default: Type J)</td></tr> <tr><td>7</td></tr> <tr><td>8</td><td>RTD Pt100, 3-wire</td></tr> <tr><td>9</td><td>0 to 20 mA</td></tr> <tr><td>10</td><td>4 to 20 mA</td></tr> <tr><td>11</td><td>0 to 80 mV</td></tr> <tr><td>12</td><td>Reserved (Default: 0 to 80 mV)</td></tr> <tr><td>13</td><td>0 to 1.25 V</td></tr> <tr><td>14</td><td>0 to 5 V</td></tr> <tr><td>15</td><td>0 to 10 V</td></tr> <tr><td>16</td><td>1 to 5 V</td></tr> </tbody> </table>	Value	Type	0	Type J Thermocouple	1	Type K Thermocouple	2	Type T Thermocouple	3	Type R Thermocouple	4	Type S Thermocouple	5	Type B Thermocouple	6	Reserved TC (Default: Type J)	7	8	RTD Pt100, 3-wire	9	0 to 20 mA	10	4 to 20 mA	11	0 to 80 mV	12	Reserved (Default: 0 to 80 mV)	13	0 to 1.25 V	14	0 to 5 V	15	0 to 10 V	16	1 to 5 V
Value	Type																																					
0	Type J Thermocouple																																					
1	Type K Thermocouple																																					
2	Type T Thermocouple																																					
3	Type R Thermocouple																																					
4	Type S Thermocouple																																					
5	Type B Thermocouple																																					
6	Reserved TC (Default: Type J)																																					
7																																						
8	RTD Pt100, 3-wire																																					
9	0 to 20 mA																																					
10	4 to 20 mA																																					
11	0 to 80 mV																																					
12	Reserved (Default: 0 to 80 mV)																																					
13	0 to 1.25 V																																					
14	0 to 5 V																																					
15	0 to 10 V																																					
16	1 to 5 V																																					
PV Units	16 bit signed integer	45	<table border="1"> <thead> <tr> <th>Value</th> <th>Unit</th> </tr> </thead> <tbody> <tr><td>0</td><td>°C</td></tr> <tr><td>1</td><td>°F</td></tr> </tbody> </table>	Value	Unit	0	°C	1	°F																													
Value	Unit																																					
0	°C																																					
1	°F																																					
PV Resolution	16 bit signed integer	46	<table border="1"> <thead> <tr> <th colspan="2">For RTD Pt100 Input</th> </tr> <tr> <th>Value</th> <th>Resolution</th> </tr> </thead> <tbody> <tr><td>0</td><td>1</td></tr> <tr><td>1</td><td>0.1</td></tr> <tr> <th colspan="2">For mV/V/mA Input</th> </tr> <tr> <th>Value</th> <th>Resolution</th> </tr> <tr><td>0</td><td>1</td></tr> <tr><td>1</td><td>0.1</td></tr> <tr><td>2</td><td>0.01</td></tr> <tr><td>3</td><td>0.001</td></tr> </tbody> </table>	For RTD Pt100 Input		Value	Resolution	0	1	1	0.1	For mV/V/mA Input		Value	Resolution	0	1	1	0.1	2	0.01	3	0.001															
For RTD Pt100 Input																																						
Value	Resolution																																					
0	1																																					
1	0.1																																					
For mV/V/mA Input																																						
Value	Resolution																																					
0	1																																					
1	0.1																																					
2	0.01																																					
3	0.001																																					

# 4-Digit Economic Universal Process Indicator

Parameter	Data Type	Address	Remark								
Signal Low	16 bit signed integer	47	<i>Resolution Based Parameter : Refer Appendix-A</i>								
Signal High	16 bit signed integer	48									
PV Range Low	16 bit signed integer	49									
PV Range High	16 bit signed integer	50									
Offset for PV	16 bit signed integer	51									
Digital Filter Time Constant	16 bit signed integer	52	<i>Resolution Based Parameter : Refer Appendix-A</i> Settable in multiples of 0.5 Seconds. Non-multiples of 0.5 are automatically converted to the nearest multiple of 5.								
Alarm-1 Type	16 bit signed integer	56	<table border="1"> <thead> <tr> <th>Value</th> <th>Type</th> </tr> </thead> <tbody> <tr> <td>0</td> <td>None</td> </tr> <tr> <td>1</td> <td>Process Low</td> </tr> <tr> <td>2</td> <td>Process High</td> </tr> </tbody> </table>	Value	Type	0	None	1	Process Low	2	Process High
Value	Type										
0	None										
1	Process Low										
2	Process High										
Alarm-2 Type	16 bit signed integer	61									
Alarm-1 SP	16 bit signed integer	42	<i>Resolution Based Parameter : Refer Appendix-A</i>								
Alarm-1 Hysteresis	16 bit signed integer	57									
Alarm-2 SP	16 bit signed integer	43									
Alarm-2 Hysteresis	16 bit signed integer	62									
Alarm-1 Inhibit	16 bit signed integer	58	<table border="1"> <thead> <tr> <th>Value</th> <th>Inhibit</th> </tr> </thead> <tbody> <tr> <td>0</td> <td>No</td> </tr> <tr> <td>1</td> <td>Yes</td> </tr> </tbody> </table>	Value	Inhibit	0	No	1	Yes		
Value	Inhibit										
0	No										
1	Yes										
Alarm-2 Inhibit	16 bit signed integer	63									
Alarm-1 Logic	16 bit signed integer	59	<table border="1"> <thead> <tr> <th>Value</th> <th>Logic</th> </tr> </thead> <tbody> <tr> <td>0</td> <td>Normal</td> </tr> <tr> <td>1</td> <td>Reverse</td> </tr> </tbody> </table>	Value	Logic	0	Normal	1	Reverse		
Value	Logic										
0	Normal										
1	Reverse										
Alarm-2 Logic	16 bit signed integer	64									
Alarm-1 Latch	16 bit signed integer	60	<table border="1"> <thead> <tr> <th>Value</th> <th>Latch</th> </tr> </thead> <tbody> <tr> <td>0</td> <td>No</td> </tr> <tr> <td>1</td> <td>Yes</td> </tr> </tbody> </table>	Value	Latch	0	No	1	Yes		
Value	Latch										
0	No										
1	Yes										
Alarm-2 Latch	16 bit signed integer	65									

# 4-Digit Economic Universal Process Indicator

Parameter	Data Type	Address	Remark										
Retrance Enable / Disable	16 bit signed integer	66	<table border="1"> <thead> <tr> <th>Value</th> <th>Command</th> </tr> </thead> <tbody> <tr> <td>0</td> <td>Disable</td> </tr> <tr> <td>1</td> <td>Enable</td> </tr> </tbody> </table>	Value	Command	0	Disable	1	Enable				
Value	Command												
0	Disable												
1	Enable												
Retransmission (Recorder) Signal Type (Output-1)	16 bit signed integer	67	<table border="1"> <thead> <tr> <th>Value</th> <th>Signal Type</th> </tr> </thead> <tbody> <tr> <td>0</td> <td>0 to 20 mA</td> </tr> <tr> <td>1</td> <td>4 to 20 mA</td> </tr> <tr> <td>2</td> <td>0 to 5 V</td> </tr> <tr> <td>3</td> <td>0 to 10 V</td> </tr> </tbody> </table>	Value	Signal Type	0	0 to 20 mA	1	4 to 20 mA	2	0 to 5 V	3	0 to 10 V
Value	Signal Type												
0	0 to 20 mA												
1	4 to 20 mA												
2	0 to 5 V												
3	0 to 10 V												
Retransmission (Recorder) Low	16 bit signed integer	68	<i>Resolution Based Parameter : Refer Appendix-A</i>										
Retransmission (Recorder) High	16 bit signed integer	69											
Alarm ACK Command	16 bit signed integer	41	<table border="1"> <thead> <tr> <th>Value</th> <th>Command</th> </tr> </thead> <tbody> <tr> <td>0</td> <td>—</td> </tr> <tr> <td>1</td> <td>ACK</td> </tr> </tbody> </table>	Value	Command	0	—	1	ACK				
Value	Command												
0	—												
1	ACK												



## APPENDIX - A

### HANDLING DECIMAL VALUES IN MODBUS REGISTERS

#### Overview

MODBUS protocol utilizes 16-bit signed integer registers (Input and Holding Registers) to store data. These registers accommodate values within the range -32,767 to 32,768. However, many process parameters require values with decimal precision. Since MODBUS registers inherently do not support floating-point values, decimal handling is achieved through scaling techniques.

This section describes how **Fixed** and **Programmable** decimal point parameters are stored and retrieved using MODBUS registers.

#### Handling Fixed Decimal Point Values

For parameters with a fixed decimal resolution, the integer values written to the MODBUS register are automatically converted by the device. However, when reading values, users must convert the retrieved integer values back to their corresponding decimal representations by dividing them by the appropriate power of 10.

*Example: Fixed Decimal Resolution of 0.01*

- Parameter Range: -12.34 to 20.00
- Scaling Factor: 100 (since  $0.01 = 10^{(-2)}$ )
- Writing a Value: To set a parameter to 34.82, write  $34.82 \times 100 = 3482$  into the register.
- Reading a Value: If the register contains 3482, the actual value is  $3482 \div 100 = 34.82$ .

This method ensures consistency in handling values with fixed decimal precision across MODBUS communication.

#### Handling Programmable Decimal Point Values

For parameters with a programmable decimal resolution, the number of decimal places is stored in a separate parameter named Resolution (or PV Resolution). The resolution value determines the scaling factor applied when storing and retrieving values in MODBUS registers.

*Resolution Parameter Definition*

The resolution parameter is stored as an integer value corresponding to the decimal precision:

Resolution Value	Decimal Precision	Scaling Factor
0	1 (No Decimals)	$10^0=1$
1	0.1	$10^1=10$
2	0.01	$10^2=100$
3	0.001	$10^3=1000$

*Example: Programmable Decimal Resolution*

- Resolution Parameter Value: 3 (corresponding to 0.001 resolution)
- Writing a Value: To set the parameter to 27.651, use Scaling Factor 1000 (corresponding to Resolution value 3) to convert the decimal value to integer value :  $27.651 \times 1000 = 27651$  and write to the MODBUS register.
- Reading a Value: If the register contains 27651, divide by 1000 ( $10^3$ ) to get 27.651.

Using this method, MODBUS allows flexible handling of parameters where decimal precision may need to be adjusted dynamically.



## APPENDIX - B DC LINEAR SIGNAL INTERFACE

### Overview

Various transmitters generate different signal types, such as mV, V, or mA, with distinct signal ranges. To ensure compatibility with a wide range of transmitters, PPI products offer configurable Signal Type and Range settings.

Common industry-standard signal ranges include:

- 0 to 80 mV, 0 to 160 mV
- 0 to 5 V, 1 to 5 V, 0 to 10 V
- 0 to 20 mA, 4 to 20 mA

Additionally, since transmitters output different signal ranges corresponding to specific process values (e.g., a 1 to 4.5 V signal may represent 5% to 95% RH), PPI products allow users to configure the process value range and resolution.

### Required Parameters for Linear Transmitter Interface

For interfacing linear transmitters, the following six parameters must be configured:

Parameter	Definition	Example
Input Type	Defines the standard DC signal type in which the transmitter signal range falls.	4 to 20 mA
Signal Low	The minimum signal value corresponding to the lowest process value.	4.00 mA
Signal High	The maximum signal value corresponding to the highest process value.	20.00 mA
PV Resolution	Defines the smallest measurable unit for the process value.	0.01 psi
Range Low	The process value corresponding to Signal Low.	0.00 psi
Range High	The process value corresponding to Signal High.	5.00 psi

### Mathematical Representation

The relationship between transmitter signal values and the corresponding process values follows a straight-line equation:

$$Y = mX + C$$

Where;

- X : Signal Value from Transmitter
- Y : Process Value Corresponding to X
- C : Process Value Corresponding to X = 0 (Y-intercept)
- m : Slope (Change in Process Value per unit Change in Signal Value)

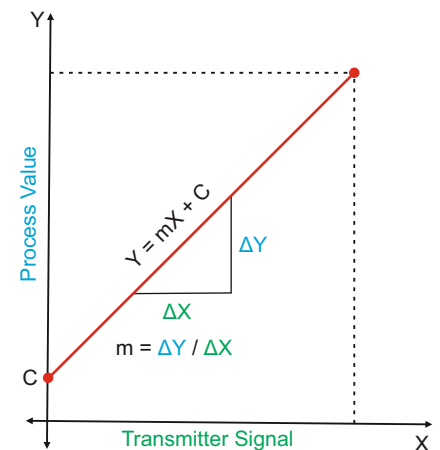

## Examples of Transmitter Configurations

### Example 1:

Pressure Transmitter (4 to 20 mA corresponding to 0 to 5 psi)

Input Type : 4-20 mA  
 Signal Low : 4.00 mA  
 Signal High : 20.00 mA  
 PV Resolution : 0.01  
 Range Low : 0.00  
 Range High : 5.00

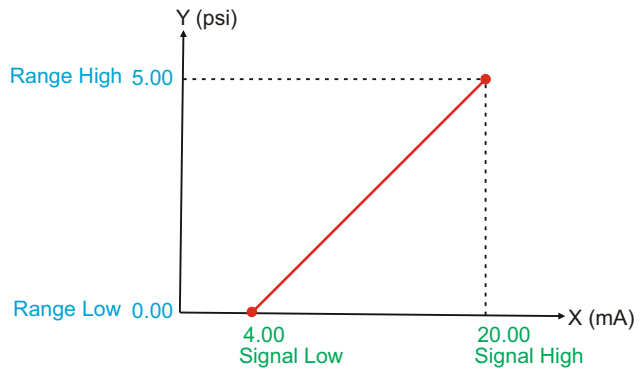

### Example 2

Humidity Transmitter (1 to 4.5 V corresponding to 5 to 95 %RH)

Input Type : 0-5 V  
 Signal Low : 1.000 V  
 Signal High : 4.500 V  
 PV Resolution : 0.1  
 Range Low : 5.0  
 Range High : 95.0

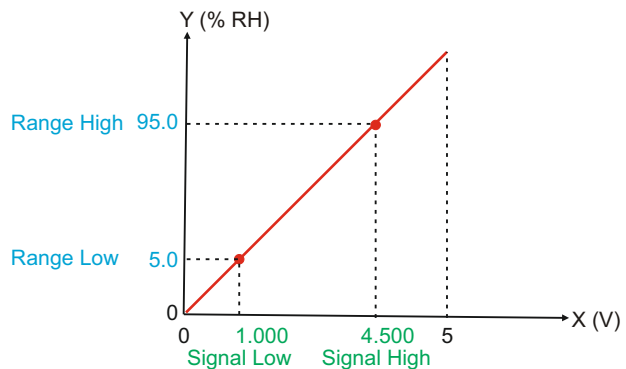

### Example 3

Temperature Transmitter (0 to 20 mA corresponding to -50 to 250 °C)

Input Type : 0-20 mA  
 Signal Low : 0.00 mA  
 Signal High : 20.00 mA  
 PV Resolution : 0.1  
 Range Low : -50.0  
 Range High : 250.0

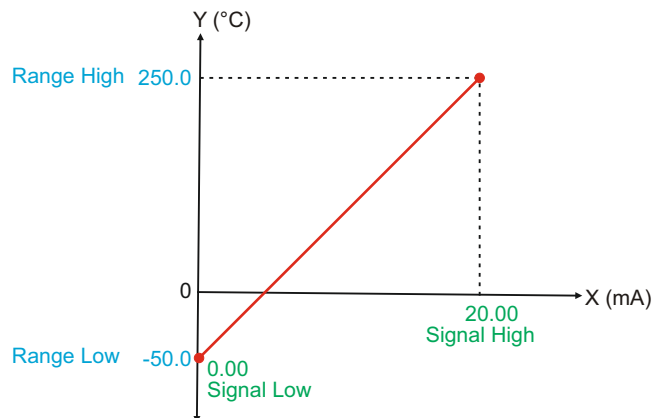





## VERSION HISTORY

Version	Release Date	Remark
01.10	18/12/2025	First Release



---

### Process Precision Instruments (An ISO 9001 : 2008 Company)

 101, Diamond Industrial Estate, Navghar, Vasai Road (E), Dist. Palghar - 401210, Maharashtra, India  
 Sales : 8208199048 / 8208141446 Support : 07498799226 / 08767395333  
 [sales@ppiindia.net](mailto:sales@ppiindia.net)  [www.ppiindia.net](http://www.ppiindia.net)