

Head Mount : TXU-01-H

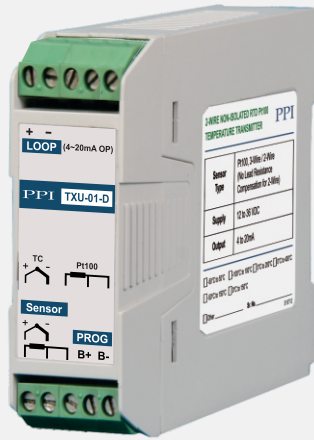

DIN-Rail Mount : TXU-01-D



Free
PC Configuration Tool

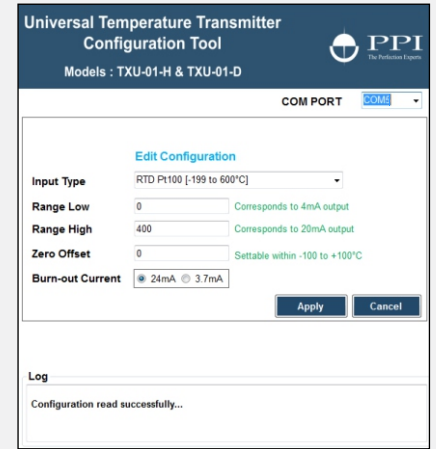

Specifications

Input																			
Sensor Type (User Programmable)	Version 1 : Pt100 Version 2 : Pt100, J, K Version 3 : Pt100, J, K, R, S, T, B, N																		
Sensor Ranges (User Settable within Min to Max.)	<table border="1"> <thead> <tr> <th>Input Type</th> <th>Range (Min. to Max.)</th> </tr> </thead> <tbody> <tr> <td>2 / 3-wire, RTD Pt100</td> <td>-199 to +600°C</td> </tr> <tr> <td>Type J Thermocouple (Fe-K)</td> <td>0 to +960°C</td> </tr> <tr> <td>Type K Thermocouple (Cr-Al)</td> <td>-200 to +1376°C</td> </tr> <tr> <td>Type T Thermocouple (Cu-Con)</td> <td>-200 to +387°C</td> </tr> <tr> <td>Type R Thermocouple (Pt / Pt-Rh13%)</td> <td>0 to +1771°C</td> </tr> <tr> <td>Type S Thermocouple (Pt / Pt-Rh10%)</td> <td>0 to +1768°C</td> </tr> <tr> <td>Type B Thermocouple</td> <td>0 to +1826°C</td> </tr> <tr> <td>Type N Thermocouple</td> <td>0 to +1314°C</td> </tr> </tbody> </table>	Input Type	Range (Min. to Max.)	2 / 3-wire, RTD Pt100	-199 to +600°C	Type J Thermocouple (Fe-K)	0 to +960°C	Type K Thermocouple (Cr-Al)	-200 to +1376°C	Type T Thermocouple (Cu-Con)	-200 to +387°C	Type R Thermocouple (Pt / Pt-Rh13%)	0 to +1771°C	Type S Thermocouple (Pt / Pt-Rh10%)	0 to +1768°C	Type B Thermocouple	0 to +1826°C	Type N Thermocouple	0 to +1314°C
Input Type	Range (Min. to Max.)																		
2 / 3-wire, RTD Pt100	-199 to +600°C																		
Type J Thermocouple (Fe-K)	0 to +960°C																		
Type K Thermocouple (Cr-Al)	-200 to +1376°C																		
Type T Thermocouple (Cu-Con)	-200 to +387°C																		
Type R Thermocouple (Pt / Pt-Rh13%)	0 to +1771°C																		
Type S Thermocouple (Pt / Pt-Rh10%)	0 to +1768°C																		
Type B Thermocouple	0 to +1826°C																		
Type N Thermocouple	0 to +1314°C																		
Corrections	<ul style="list-style-type: none"> Cold-Junction Compensation for Thermocouples (Accuracy Better than $\pm 0.5^\circ\text{C}$) Lead Resistance Compensation for Pt100 (Upto 5Ω in each lead) 																		
Linearisation	BS EN 60751(IEC 751) Standard/JISC 1604																		
Measurement Accuracy	$\pm 0.1^\circ\text{C} \pm 0.05\%$ of Reading																		
Thermal Drift	25 ppm / °C																		
Sensor Connections	Screw Terminals																		

Output	
Output Type	2-Wire, 4 to 20 mA Current Loop
Output Range	4 to 20 mA
Output Connections	Screw Terminals
Sensor Open Output Current	Selectable High Burnout Condition : 24 mA Low Burnout Condition : 3.7 mA
Accuracy	± 6 uA
Supply Voltage Effect	± 0.005% of FS per Volt
Maximum Output Load (Approx.)	[(Vsupply - 10) / (0.021)] Ohms Examples : 650Ω @ 24 VDC / 100Ω @ 12 VDC
General	
Response Time	250 mS
Supply Voltage	12 to 36 VDC (24 VDC Nominal)
Isolation	Non Isolated
Environmental (Ambient)	
Operating Range	-40 to 85°C (-40 to 185°F)
Storage Temperature	-50 to 90°C (-58 to 194°F)
Humidity Range	10 to 90% RH non-condensing

Electrical Wiring For Head Mount Transmitter

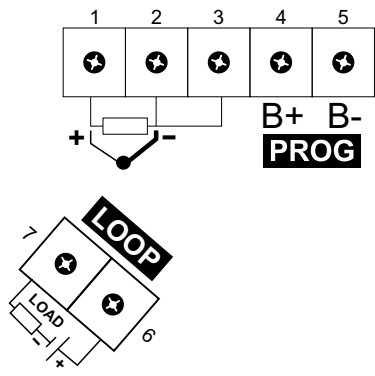

SENSOR WIRING DIAGRAM

Thermocouple
Connect Thermocouple Positive (+) to terminal 1 & Negative (-) to terminal 2.

RTD Pt100, 3-wire
For 3-Wire configuration, connect single lead end of RTD bulb to terminal 1 and the double leaded ends to terminal 2 and 3 (interchangeable).

For 2-Wire configuration, connect RTD bulb across terminals 1 & 2 (interchangeable).

LOOP WIRING DIAGRAM

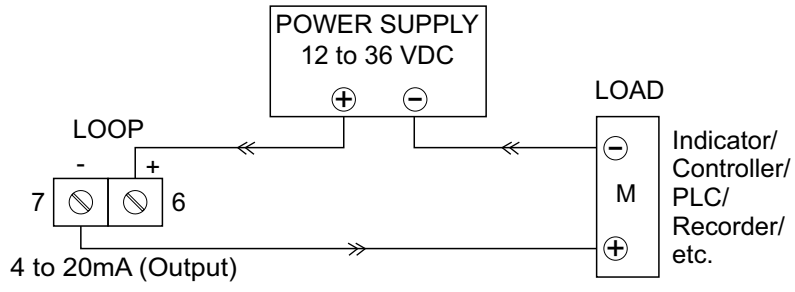

Electrical Wiring For DIN-Rail Transmitter

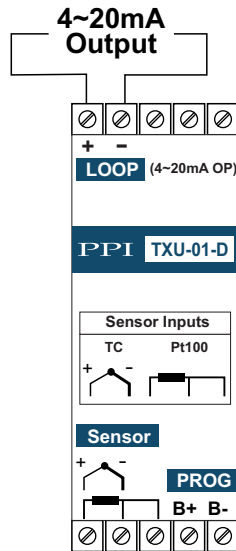

*RS485

* Use RS485 to USB converter to interface with the PC for Transmitter Configuration.

SENSOR WIRING DIAGRAM

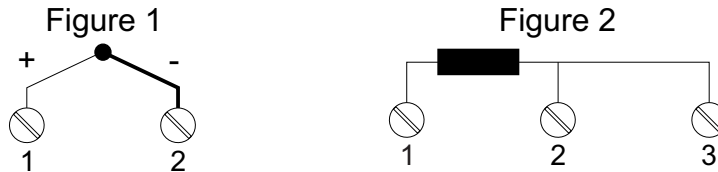

Thermocouple

Connect Thermocouple Positive to terminal marked (+) & Negative to terminal marked (-) as shown in Figure 1.

RTD Pt100, 3-Wire / 2-Wire

For 3-Wire configuration, connect single leaded end of RTD bulb to terminal 1 and the double leaded ends to terminal 2 and 3 (interchangeable) as shown in Figure 2.

For 2-Wire configuration, connect RTD bulb across terminals 1 & 2 (interchangeable).

LOOP WIRING DIAGRAM

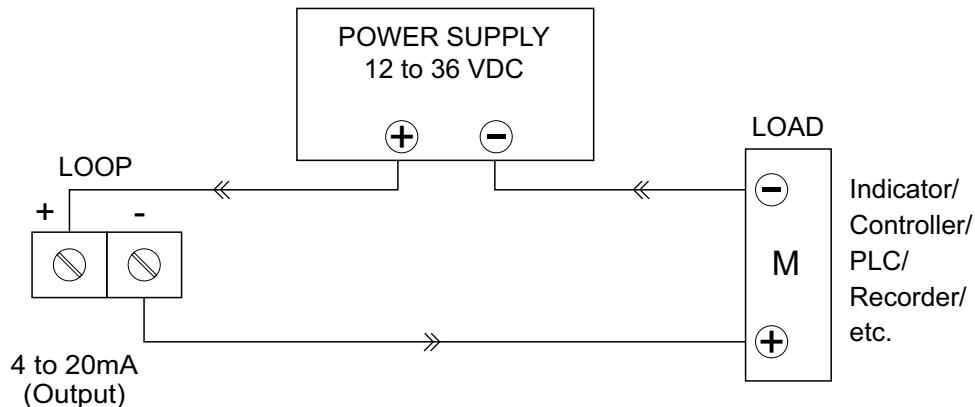

Mechanical Dimensions For Head Mount Transmitter

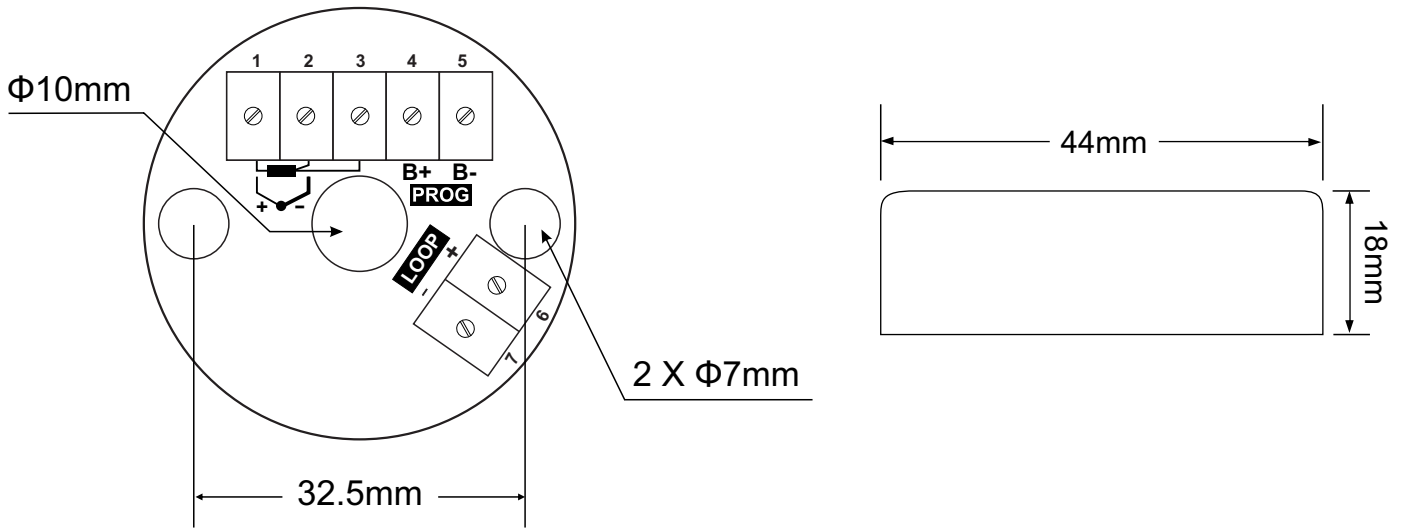

Mechanical Dimensions For DIN-Rail Transmitter

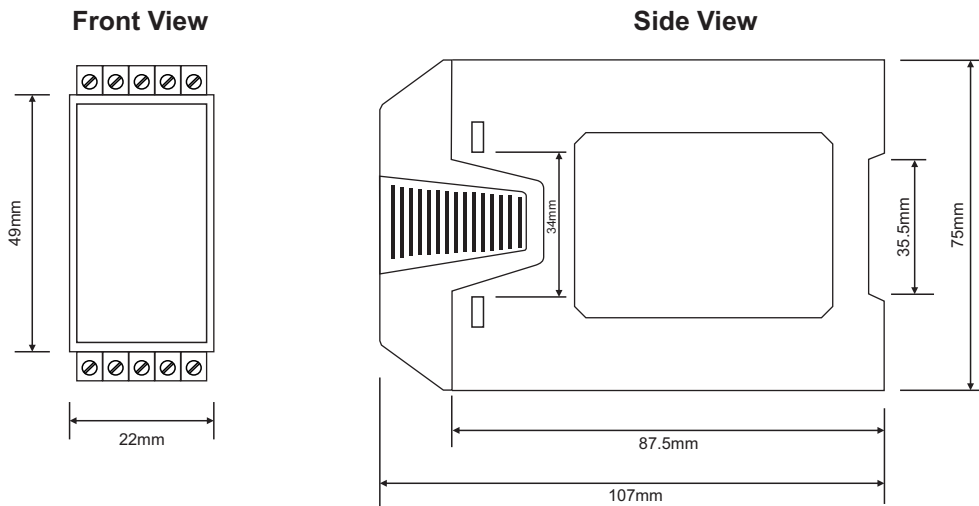

Overall Dimensions : 22(W) X 75(H) X 107(D), mm