

HumiTherm-iS Pro

Enhanced
'Temperature + Humidity' Indicator
(with Dry/Wet RTD Input Selection)

Process Precision Instruments
Vasai Road (E), Dist. Palghar - 401210,
Maharashtra, India

www.ppiindia.net

User Manual



CONTENTS

1. FRONT PANEL LAYOUT	1
2. BASIC OPERATION	3
3. SET-UP MODE : ACCESS & OPERATION	7
4. ALARM PARAMETERS	9
5. ON-OFF CONTROL PARAMETERS	11
6. INPUT CONFIGURATION PARAMETERS	12
7. SUPERVISORY PARAMETERS	14
8. RECORDER (RETRANSMISSION) PARAMETERS	16
9. HARDWARE ASSEMBLY & CONFIGURATIONS	17
10. ELECTRICAL CONNECTIONS	19
APPENDIX-A : DC LINEAR SIGNAL INTERFACE	24
APPENDIX-B : PROCESS ALARMS	26

Section 1

FRONT PANEL LAYOUT

The indicator front panel comprises of digital readouts, LED indicators and membrane keys as shown in Figure 1.1 below.

Figure 1.1

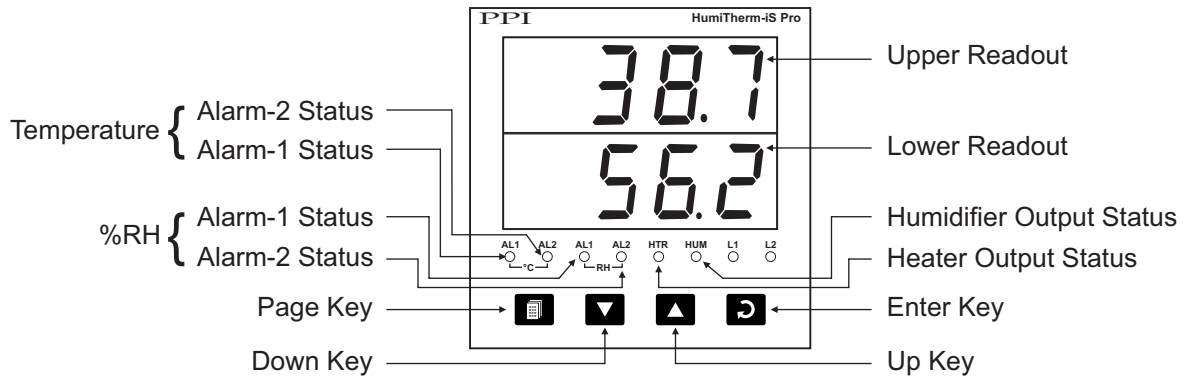

READOUTS

Upper Readout

This is a 4 digit, 7-segment bright green LED display and usually displays the Temperature Value in °C.

In Program Mode, the Upper Readout displays parameter values.

Lower Readout

This is a 4 digit, 7-segment bright green LED display and usually displays Relative Humidity (RH) Value in %. For Dry/Wet Configuration, upon holding UP or DOWN key depressed, the Lower Readout displays the Wet Bulb Temperature in °C.

In Program Mode, the Lower Readout displays prompts for the parameters.

INDICATORS

There are six front panel red LED indicators. These indicators show various statuses. The Table 1.1 below lists each LED indicator (identified by the front panel legend) and the associated status it indicates.





Table 1.1

Indicator	Function
AL1 AL2 └ °C ┘	Temperature Alarm (Alarm-1 & Alarm-2) Status <ul style="list-style-type: none"> Flashes while the Alarm is active. Remains OFF while the Alarm is inactive.
AL1 AL2 └ %RH ┘	%RH Alarm (Alarm-1 & Alarm-2) Status <ul style="list-style-type: none"> Flashes while the Alarm is active. Remains OFF while the Alarm is inactive.
HTR	Indicates control output status for Temperature
HUM	Indicates control output status for %RH
L1, L2	Unused

KEYS

There are four tactile keys provided on the front panel for configuring the indicator and setting-up the parameter values. The Table 1.2 below lists each key (identified by the front panel symbol) and the associated function.

Table 1.2

Symbol	Key	Function
	PAGE	Press to enter or exit set-up mode.
	DOWN	Press to decrease the parameter value. Pressing once decreases the value by one count; keeping pressed speeds up the change.
	UP	Press to increase the parameter value. Pressing once increases the value by one count; keeping pressed speeds up the change.
	ENTER	Press to store the set parameter value and to scroll to the next parameter on the PAGE.



Section 2 BASIC OPERATIONS

POWER-UP

Upon switching on the power to the indicator, all displays and indicators are lit on for approximately 3 seconds during which time the indicator runs through a self-test sequence. This is followed by the indication of the indicator model name on the Upper Readout and the firmware version on the Lower Readout, for approximately 1 second.

MAIN DISPLAY MODE

Figure 2.1

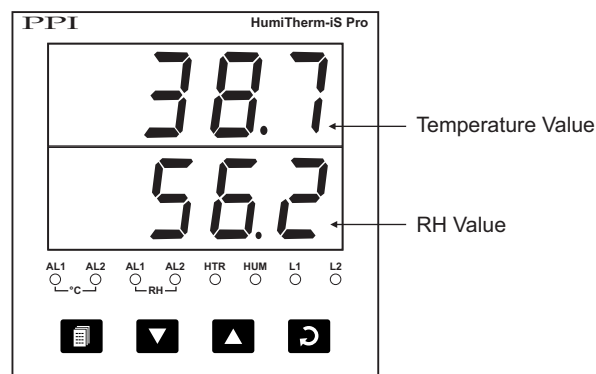

After the Power-up display sequence the indicator enters into MAIN Display Mode. This is the default mode wherein the Upper Readout displays the measured Dry Bulb Temperature in °C and the Lower Readout displays the measured / computed Relative Humidity in %. If the Indicator is configured for Dry/Wet assembly, the Wet Bulb Temperature (in °C) can be viewed by holding the UP or DOWN key depressed. The MAIN Display Mode is depicted in Figure 2.1 above.



PV ERROR INDICATIONS

The indicator flashes the PV error messages for Temperature and RH Values on Upper and Lower Readout, respectively.

▪ Error Indications for Dry-Bulb Temperature

In case of Dry-Bulb Temperature exceeding the specified Minimum or Maximum Range or in case of input sensor (RTD Pt100) open / broken; the Upper Readout flashes the Error Messages as listed in Table 2.1 below.

Table 2.1





Message	Error Type	Cause
	Over-range	Dry Bulb Temperature above Max. Range
	Under-range	Dry Bulb Temperature below Min. Range
	Sensor Open	Dry Bulb Sensor (RTD) Broken / Open

▪ Error Indication for Relative Humidity (RH)

If RH transmitter is connected for direct %RH measurement, the signal output is either DC Voltage (e.g. 0 - 5 V, 1 - 3.3 V, etc.) or DC Current (e.g. 4 - 20 mA). Thus, an open or broken sensor means either 0 V or 0 mA output. In this case the indicator reads the %RH that corresponds to this signal output. For example, consider 0-5V signal scaled to display 0.0 to 100.0 %RH. The Upper Readout then shows approximately 0.0 %RH (corresponding to 0 V) upon sensor open / broken.

- If Dry/Wet assembly is used for RH measurement and if either Wet-Bulb RTD is open / broken or there is an error condition while computing %RH value, the Lower Readout flashes the Error Messages as listed in Table 2.2 below.

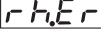
Table 2.2

Message	Error Type	Cause
	Over-range	Wet Bulb Temperature above Max. Range
	Under-range	Wet Bulb Temperature below Min. Range
	Sensor Open	Wet Bulb Sensor (RTD) Broken / Open
	RH Error	This error is indicated in the following cases : <ul style="list-style-type: none"> • Dry Bulb Temperature above 102.0°C. • Dry Bulb Temperature below -20.0°C. • Wet Bulb depression beyond: 50.0°C for Dry Bulb Temperature above 0°C 5.6°C for Dry Bulb Temperature below 0°C
	Display Freezes To 100.0%	This error is indicated in the following cases : <ul style="list-style-type: none"> • Wet-Bulb Temperature exceeds Dry-Bulb Temperature. • Computed % RH above 100.0%.
	Display Freezes To 0.0%	Computed % RH is below 0.0%.

Note:

For both Dry and Wet Bulb, 3-wire RTD sensor input, if the compensating lead is not connected or gets open, the indicator does not indicate PV error but the measured value is not compensated for the lead resistance.

ALARM STATUS UNDER PV ERROR CONDITIONS



For Alarm activation, the *Under-range* condition is treated as minimum PV, whereas the *Over-range* and *Open* conditions are treated as maximum PV. Thus, Process High Alarm is activated upon *Over-range/Open error*. Similarly, Process Low Alarm is activated upon *Under-range error*. An *RH Error* condition activates Alarm associated with RH measurement.

OPERATOR PAGE AND PARAMETERS

The parameters that may require frequent settings or viewing are organized on a separate page, called the Operator Page. The editing of the operator parameters is however selectively controlled at supervisory level and the parameter setting cannot be locked by the Master Lock.

Accessing Operator Page & Adjusting Parameters

Step through the following sequence to open the Operator Page and to adjust the operator parameter values.

1. Press and release PAGE key. The Lower Readout shows  (PAGE) and Upper Readout shows  (0).
2. Press ENTER key. The Lower Readout shows prompt for the first available operator parameter and the Upper Readout shows value for the parameter.
3. Use UP / DOWN keys to adjust the value and then press ENTER key to store the set value and scroll to the next parameter.

Use PAGE key to return to MAIN Display Mode.





The operator parameters are described in Table 2.3. Note that the parameters presented on Operator Page depend upon the functions selected/enabled.

The operator parameter list mainly includes :

- a) Min / Max Process Monitoring Values & Parameters.
- b) Setpoint Values for Alarms.

Table 2.3

Parameter Description	Settings (Default Value)
MAXIMUM DRY - BULB TEMPERATURE VALUE db.Hi This parameter indicates the Maximum value attained by the Dry-Bulb Temperature. This is a read only value.	View Only
MINIMUM DRY - BULB TEMPERATURE VALUE db.Lo This parameter indicates the Minimum value attained by the Dry-Bulb Temperature. This is a read only value.	View Only
MAXIMUM %RH VALUE rh.Hi This parameter indicates the Maximum value attained by the Relative Humidity. This is a read only value.	View Only
MINIMUM %RH VALUE rh.Lo This parameter indicates the Minimum value attained by the Relative Humidity. This is a read only value.	View Only
RESET COMMAND rSt Set this parameter to 'Yes' followed by correct password entry (through next parameter) to clear the current Min/Max values and start afresh monitoring the PV for new Min/Max values.	no No YES Yes (Default : No)
RESET PASSWORD CODE For resetting the Min/Max values, set the reset command to 'Yes' and then enter the correct password.	0 to 9999 (Default : 0)
SELECT CHANNEL SEL Select the Temperature or RH channel for setting Control and/or Alarm setpoints through the subsequent parameters.	00 Temp rh Humidity (Default : Temp)

Parameter Description	Settings (Default Value)
<p>TEMPERATURE CONTROL SETPOINT </p> <p>or</p> <p>RH CONTROL SETPOINT </p> <p><i>(Available only if the Control Function is enabled for the selected channel)</i></p> <p>Depending on the selected channel, either temperature or RH setpoint parameter is presented if On-Off control feature is enabled. This parameter sets the value for On-Off control action.</p>	<p>Setpoint Low Limit to Setpoint High Limit (Default : 0.0)</p>
<p>TEMPERATURE or RH ALARM-1 SETPOINT </p> <p>Depending on the selected channel, this parameter sets the limit for either temperature or RH Alarm-1. This parameter is presented only if Alarm type is selected as Process High or Process Low.</p>	<p>Setpoint Low Limit to Setpoint High Limit (Default : 0.0)</p>
<p>TEMPERATURE or RH ALARM-2 SETPOINT </p> <p>Depending on the selected channel, this parameter sets the limit for either temperature or RH Alarm-2. This parameter is presented only if Alarm type is selected as Process High or Process Low.</p>	<p>Setpoint Low Limit to Setpoint High Limit (Default : 0.0)</p>



Section 3

SET-UP MODE : ACCESS AND OPERATION

The various parameters are arranged in different groups depending upon the functions they represent. Each such group is called a PAGE and is assigned a unique numeric value, called PAGE NUMBER, for its access.

The parameters are always presented in a fixed format: The Lower Readout displays the parameter prompt (Identification Name) and the Upper Readout displays the set value. The parameters appear in the same sequence as listed in their respective sections.

SET-UP MODE

The Set-up Mode allows the user to view and modify the parameter values. Follow the steps below for setting the parameter values:

1. Press and release PAGE key. The Lower Readout shows `PAGE` and the Upper Readout shows page number `0` (0). Refer Figure 3.1.
2. Use UP / DOWN keys to set the desired PAGE NUMBER.
3. Press and release ENTER key. The Lower Readout shows the prompt for the first parameter listed in the set PAGE and the Upper Readout shows its current value. If the entered PAGE NUMBER is invalid (contains no parameter list or any associated function), the indicator reverts to the MAIN Display Mode.
4. Press and release the ENTER key until the prompt for the required parameter appears on the Lower Readout. (The last parameter in the list rolls back to the first parameter).
5. Use UP / DOWN keys to adjust the parameter value. (The display flashes if UP key is pressed after reaching the maximum value or DOWN key is pressed after reaching the minimum value).
6. Press and release the ENTER key. The new value gets stored in the indicator's non-volatile memory and the next parameter in the list is displayed.

The Figure 3.1 illustrates the example of altering the value for the parameter 'Input Type for Temperature Channel'.

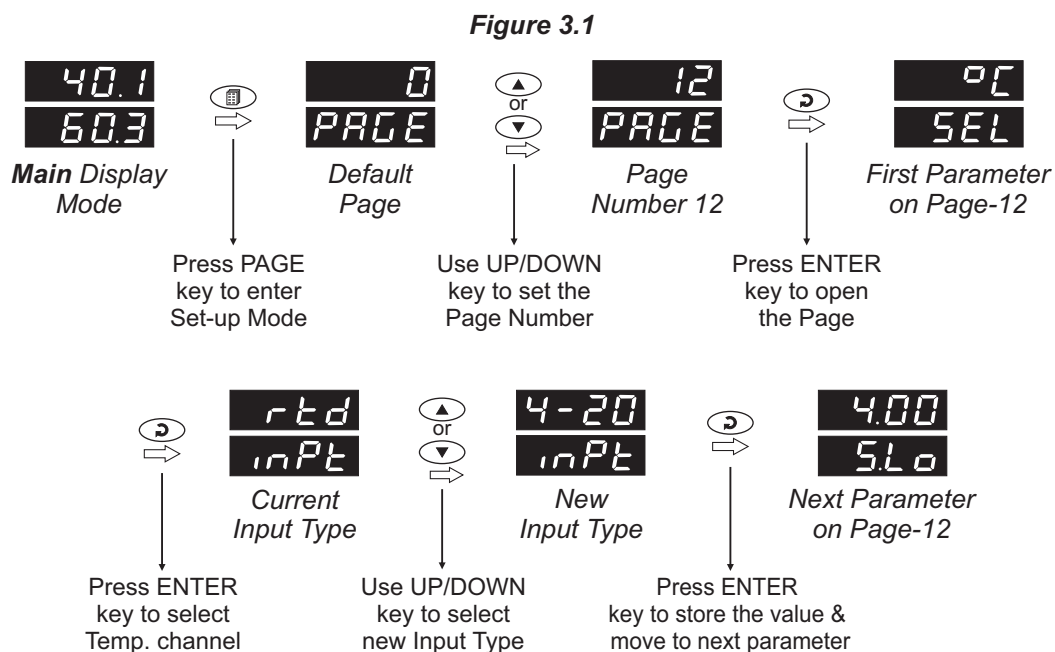

Notes

1. Each page contains a fixed list of parameters that are presented in a pre-determined sequence. Note however that availability of a few parameters, called Conditional Parameters, depend upon the settings for some other parameters. For example, the parameters 'Range Low' & 'Range High' are not available if the selected Input Type is RTD.
2. To exit the set-up mode and return to the MAIN Display Mode, press and release PAGE key.
3. If no key is pressed for approximately 30 seconds, the set-up mode times out and reverts to the MAIN Display Mode.

MASTER LOCKING

The indicator facilitates locking all the PAGES (except Operator PAGE) by applying Master Lock Code. Under Locking, the parameters are available for *view only* and cannot be adjusted. The Master Lock, however does not lock the operator parameters. This feature allows protecting the rather less frequently used parameters against any inadvertent changes while making the frequently used operator parameters still available for any editing.

For enabling / disabling the Lock, step through the following sequence:

Locking

1. Press and release PAGE key while the indicator is in the MAIN Display Mode. The Lower Readout shows `PAGE` (PAGE) and the Upper Readout shows `0` (0).
2. Use UP / DOWN keys to set the Page Number to 123 on the Upper Readout.
3. Press and release ENTER key. The indicator returns to the MAIN Display Mode with the Lock enabled.

The Figure 3.2 below illustrates the Locking procedure.

Figure 3.2

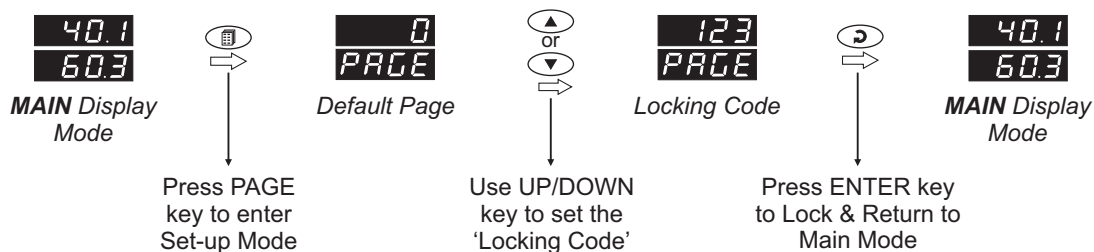

UnLocking

Repeat the Locking procedure twice for unlocking.



Section 4

PAGE-10 : ALARM PARAMETERS

The Alarm Parameters for both *Temperature* and *RH* are similar and grouped under their respective channel. To select and edit any parameters for *Temperature* or *RH*, first select the appropriate channel using the parameter 'SEL' (Select).

Refer Table 4.1 for parameter description and settings. [For details on Process Alarm refer Appendix - B.](#)

Table 4.1

Parameter Description	Settings (Default Value)
<p>SELECT CHANNEL SEL</p> <p>Select the Temperature or RH channel for viewing and/or editing the Alarm settings through the subsequent parameters.</p>	<p>0C Temp rh Humidity (Default : Temp)</p>
<p>ALARM FUNCTION ALFC</p> <p><i>Alarm</i> The alarm relay turns-on upon alarm activation. Select this function if an Audio / Visual device is to be activated upon alarm.</p> <p><i>Trip</i> The alarm relay turns-off upon alarm activation. Select this function if some process/device is to be de-activated upon alarm.</p>	<p>ALrā Alarm t.r.P Trip (Default : Alarm)</p>
<p>ALARM LATCH ALLT</p> <p><i>No</i> The Relay switches ON/OFF with Alarm status.</p> <p><i>Yes</i> The Relay once switched upon alarm activation remains so until 'Acknowledged' upon removal of alarm condition.</p>	<p>no No YES Yes (Default : No)</p>
<p>ALARM 1 TYPE A1TY</p> <p><i>None</i> The Alarm function is disabled.</p> <p><i>Process Low</i> The Alarm is activated upon the Temperature/RH value equaling or falling below the 'Alarm Setpoint' value.</p> <p><i>Process High</i> The Alarm is activated upon the Temperature/RH value equaling or rising above the 'Alarm Setpoint' value.</p>	<p>none None P_Lo Process Low P_Hi Process High (Default : None)</p>
<p>ALARM-1 HYSTERESIS A1HY</p> <p>(Not Available if Alarm Type is None)</p> <p>This parameter sets a differential (dead) band between the ON and OFF Alarm status change. Keep it large enough to avoid frequent switching of the Alarm relay.</p>	<p>0.2 to 99.9 (Default : 2.0)</p>

Parameter Description	Settings (Default Value)
<p>ALARM-1 INHIBIT A 1, h</p> <p><i>(Not Available if Alarm Type is None)</i></p> <p>Yes The Alarm activation is suppressed until the Temperature/RH value is within Alarm limits from the time the indicator is switched ON. This allows suppressing the Alarm during the start-up Alarm conditions.</p> <p>No The Alarm is not suppressed during the start-up Alarm conditions.</p>	<div style="display: flex; flex-direction: column; align-items: center;"> <div style="display: flex; align-items: center; margin-bottom: 5px;"> <div style="border: 1px solid black; padding: 2px; margin-right: 5px;">no</div> No </div> <div style="display: flex; align-items: center; margin-bottom: 5px;"> <div style="border: 1px solid black; padding: 2px; margin-right: 5px;">YES</div> Yes </div> <p>(Default : Yes)</p> </div>
<p>ALARM 2 TYPE A2,t4</p> <p>ALARM-2 HYSTERESIS A2,H4</p> <p>ALARM-2 INHIBIT A2, h</p> <p><i>The parameter descriptions and settings are the same as that for Alarm-1.</i></p>	



Section 5

PAGE 11 : ON-OFF CONTROL PARAMETERS

The Control Parameters for both *Temperature* and *RH* are similar and grouped under their respective channel. To select and edit any parameters for *Temperature* or *RH*, first select the appropriate channel using the parameter 'SEL' (Select).

Refer Table 5.1 for parameter description and settings.

Table 5.1

Parameter Description	Settings (Default Value)
SELECT CHANNEL SEL Select the Temperature or RH channel for viewing and/or editing the Control settings through the subsequent parameters.	00 Temp rh Humidity (Default : Temp)
CONTROL FUNCTION Ctrl <i>Disable</i> The On-Off Control for the selected channel is disabled. <i>Enable</i> The On-Off Control for the selected channel is enabled.	d5bL Disable EnbL Enable (Default : Disable)
The following parameters are presented only if the <i>Control Function</i> parameter is set to 'Enable'.	
CONTROL MODE tYPE <i>Cool (or De-hum)</i> The control action is performed to switch-on a cooling (or de-humidification) gadget whenever the temperature (or humidity) rises above the control setpoint and vice-a-versa. <i>Heat (or Hum)</i> The control action is performed to switch-on a heating (or humidification) gadget whenever the temperature (or humidity) falls below the control setpoint and vice-a-versa.	Cool Cool HEAT Heat } Temperature Channel (Default : Heat)
	dhUā De-hum hUā Hum } RH Channel (Default : Hum)
SETPOINT LOW LIMIT SP.Lo Sets minimum permissible control setpoint value.	Input Type Minimum Range to Setpoint High Limit (Default : 0.0)
SETPOINT HIGH LIMIT SP.Hi Sets maximum permissible control setpoint value.	Setpoint Low Limit to Input Type Maximum Range (Default : 100.0)
HYSTERESIS HYSt Sets differential (dead) band between On-Off switching of Temperature or Humidity gadget.	0.1 to 99.9 (Default : 2.0)



Section 6

PAGE 12 : INPUT CONFIGURATION PARAMETERS

The Controller supports interface for both RTD Pt100 Sensors and DC Current / Voltage outputs from Temperature/RH Transmitters. The Parameters on this PAGE allows appropriate configuration for available input types for each channel (Temperature & RH). The parameters for both *Temperature* and *RH* input types are similar and grouped under their respective channel. To select and edit any parameters for *Temperature* or *RH*, first select the appropriate channel using the parameter 'SEL' (Select).

Refer Table 6.1 for parameter description and settings.

Table 6.1

Parameter Description	Settings (Default Value)																					
SELECT CHANNEL SEL Select the Temperature or RH channel for Input Sensor configurations.	0C Temp rh Humidity (Default : Temp)																					
INPUT TYPE inPt Select Input type in accordance with the type of Temperature or RH sensor/transmitter connected for measurement.	Refer Table 6.1 (Default For Temp. : RTD, For RH : 0 to 5.0)																					
SIGNAL LOW SLo <i>(Available for DC linear mV/V/mA Inputs only)</i> The transmitter output signal value corresponding to Range Low process value. Refer <i>Appendix-A : DC Linear Signal Interface</i> for details.	<table border="1"> <thead> <tr> <th>Input Type</th> <th>Settings</th> <th>Default</th> </tr> </thead> <tbody> <tr> <td>0 to 20 mA</td> <td>0.00 to Signal High</td> <td>0.00</td> </tr> <tr> <td>4 to 20 mA</td> <td>4.00 to Signal High</td> <td>4.00</td> </tr> <tr> <td>0 to 1.25 V</td> <td>0.000 to Signal High</td> <td>0.000</td> </tr> <tr> <td>0 to 5 V</td> <td>0.000 to Signal High</td> <td>0.000</td> </tr> <tr> <td>0 to 10 V</td> <td>0.00 to Signal High</td> <td>0.00</td> </tr> <tr> <td>1 to 5 V</td> <td>1.000 to Signal High</td> <td>1.000</td> </tr> </tbody> </table>	Input Type	Settings	Default	0 to 20 mA	0.00 to Signal High	0.00	4 to 20 mA	4.00 to Signal High	4.00	0 to 1.25 V	0.000 to Signal High	0.000	0 to 5 V	0.000 to Signal High	0.000	0 to 10 V	0.00 to Signal High	0.00	1 to 5 V	1.000 to Signal High	1.000
Input Type	Settings	Default																				
0 to 20 mA	0.00 to Signal High	0.00																				
4 to 20 mA	4.00 to Signal High	4.00																				
0 to 1.25 V	0.000 to Signal High	0.000																				
0 to 5 V	0.000 to Signal High	0.000																				
0 to 10 V	0.00 to Signal High	0.00																				
1 to 5 V	1.000 to Signal High	1.000																				
SIGNAL HIGH SHI <i>(Available for DC linear mV/V/mA Inputs only)</i> The transmitter output signal value corresponding to Range High process value. Refer <i>Appendix-A : DC Linear Signal Interface</i> for details.	<table border="1"> <thead> <tr> <th>Input Type</th> <th>Settings</th> <th>Default</th> </tr> </thead> <tbody> <tr> <td>0 to 20 mA</td> <td>Signal Low to 20.00</td> <td>20.00</td> </tr> <tr> <td>4 to 20 mA</td> <td>Signal Low to 20.00</td> <td>20.00</td> </tr> <tr> <td>0 to 1.25 V</td> <td>Signal Low to 1.250</td> <td>1.250</td> </tr> <tr> <td>0 to 5 V</td> <td>Signal Low to 5.000</td> <td>5.000</td> </tr> <tr> <td>0 to 10 V</td> <td>Signal Low to 10.00</td> <td>10.00</td> </tr> <tr> <td>1 to 5 V</td> <td>Signal Low to 5.000</td> <td>5.000</td> </tr> </tbody> </table>	Input Type	Settings	Default	0 to 20 mA	Signal Low to 20.00	20.00	4 to 20 mA	Signal Low to 20.00	20.00	0 to 1.25 V	Signal Low to 1.250	1.250	0 to 5 V	Signal Low to 5.000	5.000	0 to 10 V	Signal Low to 10.00	10.00	1 to 5 V	Signal Low to 5.000	5.000
Input Type	Settings	Default																				
0 to 20 mA	Signal Low to 20.00	20.00																				
4 to 20 mA	Signal Low to 20.00	20.00																				
0 to 1.25 V	Signal Low to 1.250	1.250																				
0 to 5 V	Signal Low to 5.000	5.000																				
0 to 10 V	Signal Low to 10.00	10.00																				
1 to 5 V	Signal Low to 5.000	5.000																				
RANGE LOW r.Lo <i>(Available for DC linear mV/V/mA Inputs only)</i> The process value corresponding to the Signal Low value from the transmitter. Refer <i>Appendix-A : DC Linear Signal Interface</i> for details.	-199.9 to 999.9 (Default : 0.0)																					

Parameter Description	Settings (Default Value)
<p>RANGE HIGH r.H 1</p> <p><i>(Available for DC linear mV/V/mA Inputs only)</i></p> <p>The process value corresponding to the Signal High value from the transmitter. Refer <i>Appendix-A : DC Linear Signal Interface</i> for details.</p>	<p>-199.9 to 999.9 (Default : 100.0)</p>
<p>OFFSET OFFSE</p> <p>This value is algebraically added to the measured Temperature / RH Value to derive the final Value that is displayed and compared for alarm / control. Use this value to nullify any known constant error.</p> <p>Final Value = Measured Value + Offset</p> <p><i>Note :</i> <i>For Dry/Wet Configuration, the offset value for RH channel applies in °C to Wet RTD and not to computed %RH.</i></p>	<p>-99.9 to 99.9 (Default : 0.0)</p>
<p>FILTER FILTE</p> <p>Sets the time constant, in seconds, for the low-pass digital filter applied to the measured PV. The filter helps smoothing / averaging the signal input and removing the undesired noise. The higher the filter value the lower the indication response to the PV changes and vice-a-versa.</p>	<p>0.5 to 60.0 Seconds (in steps of 0.5 Seconds) (Default : 2.0 sec.)</p>

Table 6.2

Option	What it means	Range (Min. to Max.)	Resolution
rtd	3-wire, RTD Pt100	-199.9 to +600.0°C	0.1 °C
0-20	0 to 20mA DC current	-199.9 to 999.9 units	0.1 units
4-20	4 to 20mA DC current		
RES.1	Reserved (Default : 0 to 20mV)		
RES.2			
1.25	0 to 1.25V DC voltage		
5.0	0 to 5.0V DC voltage		
10.0	0 to 10.0V DC voltage		
1-5	1 to 5.0V DC voltage		

Section 7

PAGE 13 : SUPERVISORY PARAMETERS

The supervisory level responsibilities include exercising control over operator, making process related decisions and controlling the availability of process data for remote use.

The Table 7.1 below list supervisory parameters.

Table 7.1

Parameter Description	Settings (Default Value)
CONTROL SET-POINT ADJUSTMENT ON OPERATOR PAGE SP.OP Supervisory permission for Control set-points adjustments on Operator Page. Set to 'Enable' for permission.	d5bL Disable EnbL Enable (Default : Disable)
ALARM SET-POINT ADJUSTMENT ON OPERATOR PAGE AL.OP Supervisory permission for Alarm set-points adjustments on Operator Page. Set to 'Enable' for permission.	d5bL Disable EnbL Enable (Default : Disable)
REMOTE ACKNOWLEDGE SWITCH rñt.A Supervisory permission for use of the rear panel terminals for connecting remote switch for Alarm acknowledge.	d5bL Disable EnbL Enable (Default : Disable)
PASSWORD FOR RESETTING MIN/MAX COdE This parameter allows protection against inadvertent resetting of Min/Max values using Reset Command on Operator Page. That is, the reset command is executed only if the operator enters the password that matches with this parameter value.	1 to 9999 (Default : 0)
DEVICE SLAVE ID 1d (Applicable for Serial Communication) Unique numeric code assigned to the indicator for identification by the host. Set the value as required by the host.	1 to 127 (Default : 1)
BAUD RATE baud (Applicable for Serial Communication) This parameter sets communication speed in 'Bits per Second'. Set the value to match with the host baud rate.	4.8 4800 9.6 9600 19.2 19200 (Default : 9600)

Parameter Description	Settings (Default Value)
<p>PARITY PAR 1</p> <p>(Applicable for Serial Communication)</p> <p>One of the communication error trapping features. Select the data packet parity as implemented by the host protocol.</p>	<div style="display: flex; flex-direction: column; gap: 5px;"> <div style="display: flex; align-items: center;"> none None </div> <div style="display: flex; align-items: center;"> Even Even </div> <div style="display: flex; align-items: center;"> Odd Odd </div> </div> <p>(Default : Even)</p>
<p>SERIAL WRITE PERMISSION CoñE</p> <p>(Applicable for Serial Communication)</p> <p>Setting to 'No' disallows the host to set / modify any parameter values. The host, however, can read the values.</p>	<div style="display: flex; flex-direction: column; gap: 5px;"> <div style="display: flex; align-items: center;"> no No </div> <div style="display: flex; align-items: center;"> YES Yes </div> </div> <p>(Default : No)</p>



Section 8

PAGE 15 : RETRANSMISSION PARAMETERS

The retransmission parameters include selecting the signal output type and the Temperature/RH Range. The parameters for both *Temperature* and *RH* retransmission are similar and grouped under their respective channel. To select and edit any parameters for *Temperature* or *RH*, first select the appropriate channel using the parameter 'SEL' (Select).

Refer Table 8.1 for parameter description & settings.

Table 8.1

Parameter Description	Settings (Default Value)
<p>SELECT CHANNEL SEL</p> <p>Select the Temperature or RH channel for setting the respective retransmission parameters.</p>	<div style="display: flex; flex-direction: column; align-items: flex-start;"> <div style="margin-bottom: 5px;">00 Temp</div> <div style="margin-bottom: 5px;">RH Humidity</div> <p>(Default : Temp)</p> </div>
<p>RETRANSMISSION OUTPUT TYPE rEt.o</p> <p>Select type in accordance with the hardware module fitted.</p> <p>Select 0-20 or 4-20 mA, if Current output module is fitted. Select 0-5 or 0-10 V, if Voltage output module is fitted.</p>	<div style="display: flex; flex-direction: column; align-items: flex-start;"> <div style="margin-bottom: 5px;">0-20 0 - 20 mA</div> <div style="margin-bottom: 5px;">4-20 4 - 20 mA</div> <div style="margin-bottom: 5px;">0-5 0 - 5 V</div> <div style="margin-bottom: 5px;">0-10 0 - 10 V</div> <p>(Default : 4 - 20 mA)</p> </div>
<p>RETRANSMISSION LOW rEt.L</p> <p>Set the Low-side Temperature/RH Value that shall correspond to the minimum retransmission output signal level (0 mA/ 4 mA/ 0 V).</p>	<p>Input Type Minimum Range to Input Type Maximum Range (Default : 0.0)</p>
<p>RETRANSMISSION HIGH rEt.H</p> <p>Set the High-side Temperature/RH Value that shall correspond to the maximum retransmission output signal level (20 mA/ 10 V / 5 V).</p>	<p>Input Type Minimum Range to Input Type Maximum Range (Default : 100.0)</p>



Section 9

MECHANICAL INSTALLATION

The following precautions should be strictly observed while installing the indicator:

1. The place of installation should be free of corrosive/combustible gases and electrically conductive pollution.
2. Ensure that the place of installation is not subject to rapid ambient changes that can cause condensation. Also the Ambient Temperature and Relative Humidity surrounding the indicator should not exceed the maximum specified for the proper operation of the indicator.
3. The place of installation should be adequately protected against excessive electrostatic or electromagnetic interference.
4. The indicator should not be subject to direct vibration or shock.
5. The indicator should not be exposed to dust, salt air, direct sunlight or radiant heat.

OUTER DIMENSIONS

The Figure 9.1 shows the outer dimensions of the indicator.

Figure 9.1

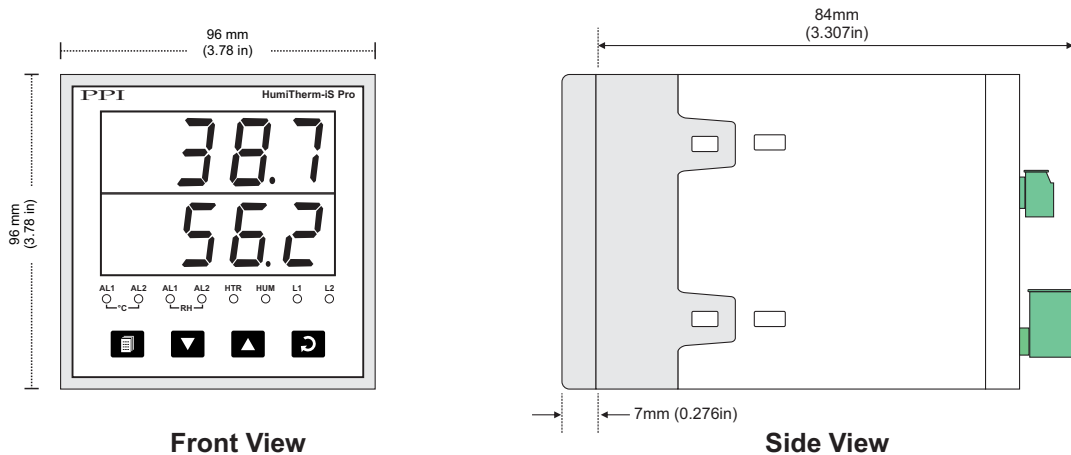

PANEL CUTOUT AND RECOMMENDED MINIMUM SPACING

The Figure 9.2 shows the panel cutout requirements for a single indicator and also the minimum spacing recommended if several indicators are required to be mounted on a panel.

Figure 9.2

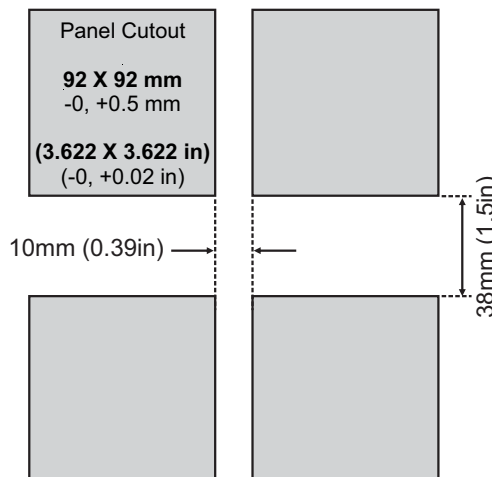

PANEL MOUNTING

Follow the steps below for mounting the indicator on panel:

1. Prepare a square cutout to the size shown in Figure 9.2.
2. Remove the Mounting Clamps from the indicator Enclosure.
3. Insert the rear of the indicator housing through the panel cutout from the front of the mounting panel.
4. Hold the indicator gently against the mounting panel such that it positions squarely against the panel wall, see Figure 9.3. Apply pressure only on the bezel and not on the front label.
5. Fix the Mounting Clamps (one after the other) such that the metallic projection fits in the square hole provided on the top and bottom sides of the enclosure. Tighten the clamp screw until the clamps firmly secure against the panel wall.

Figure 9.3

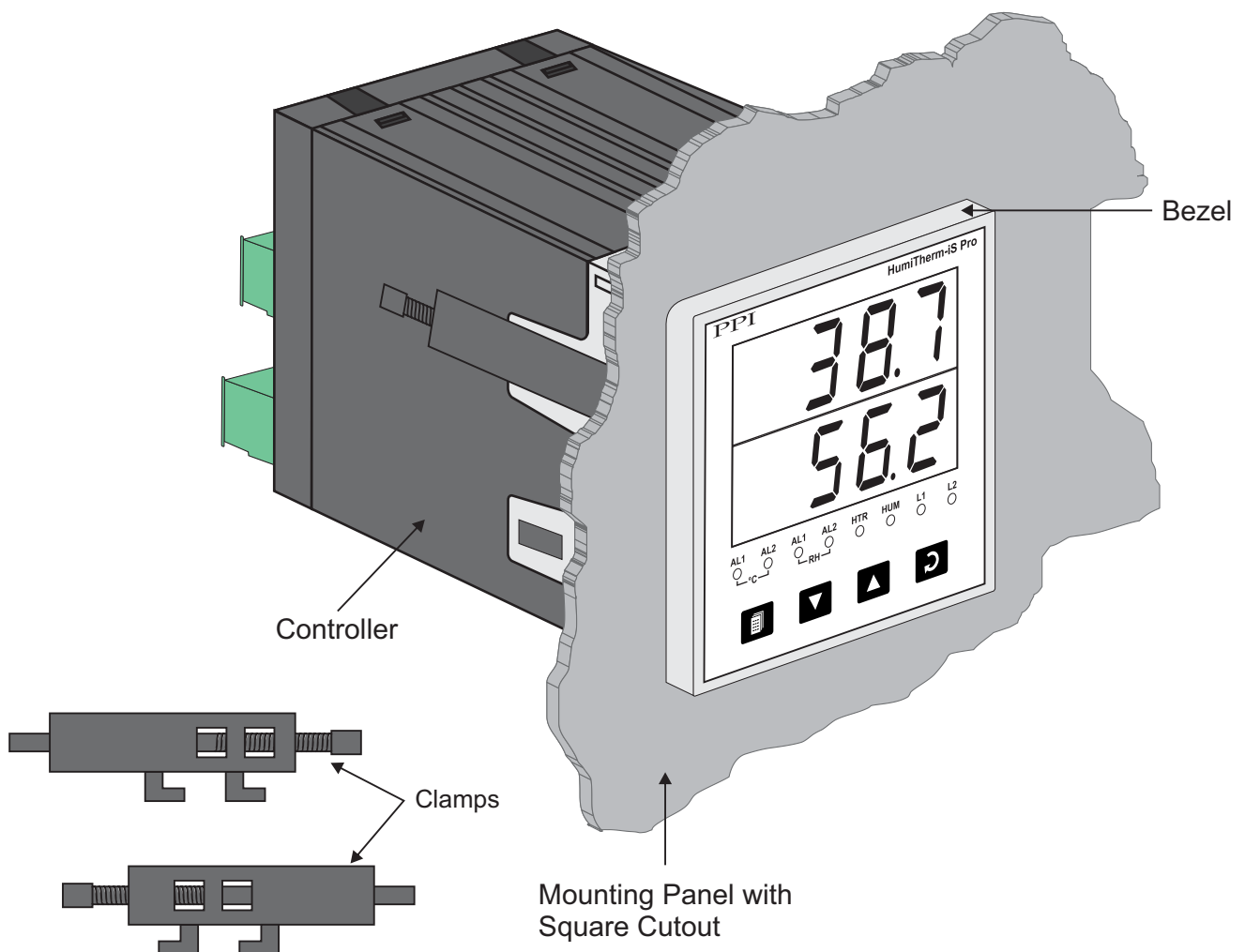

Section 10

ELECTRICAL CONNECTIONS

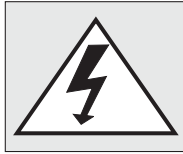

WARNING
MISHANDLING / NEGLIGENCE CAN
RESULT IN PERSONAL DEATH OR
SERIOUS INJURY.

1. The user must rigidly observe the Local Electrical Regulations.
2. Do not make any connections to the unused terminals for making a tie-point for other wires (or for any other reasons) as they may have some internal connections. Failing to observe this may result in permanent damage to the indicator.
3. Run power supply cables separated from the low-level signal cables (like **RTD**, **DC** Linear Current/Voltage, etc.). If the cables are run through conduits, use separate conduits for power supply cable and low-level signal cables.
4. Use appropriate fuses and switches, wherever necessary, for driving the high voltage loads to protect the indicator from any possible damage due to high voltage surges of extended duration or short-circuits on loads.
5. Take care not to over-tighten the terminal screws while making connections.
6. Make sure that the indicator supply is switched-off while making/removing any connections or removing the indicator from its enclosure.

CONNECTION DIAGRAM

The Electrical Connection Diagram is shown on the rear side of the indicator enclosure. The Connection Diagram is a generic one; the connections shown for optional modules are applicable only if the modules are fitted.

Figure 10.1

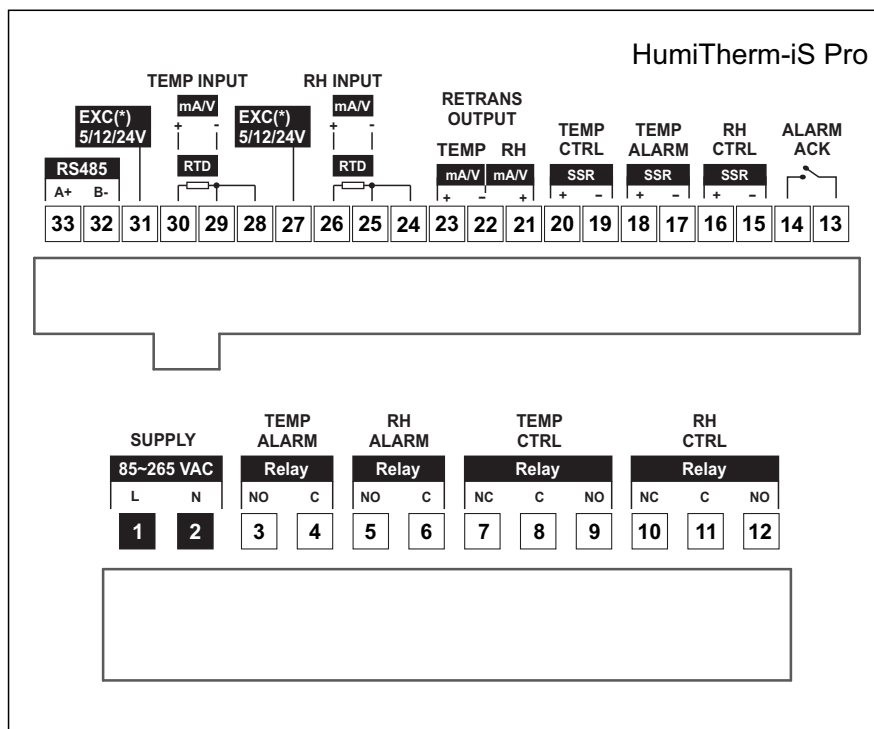

DESCRIPTIONS

TEMP INPUT : RTD Pt100, 3-Wire / mA/V (Terminals 30, 29, 28)

RH INPUT : RTD Pt100, 3-Wire / mA/V (Terminals 26, 25, 24)

Figure 10.2 (a) : RTD Input

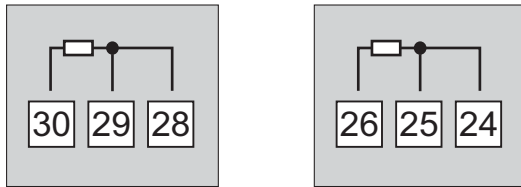

Temperature Input

Humidity Input

Figure 10.2 (b) : mA / V Input

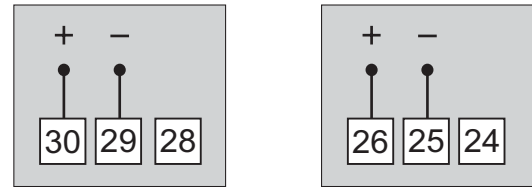

Temperature Input

Humidity Input

* Refer "EXC 5/12/24VDC : Excitation Voltage for Transmitters (Terminal : 31, 27)"

RTD Pt100, 3-wire

Connect single lead end of RTD bulb to terminal 30 (26) and the double lead ends to terminal 29 (25) and 28 (24), interchangeable, as shown in Figure 10.2 (a). Use copper conductor leads of very low resistance ensuring that all 3 leads are of the same gauge and length. Avoid joints in the cable.

DC Linear Signal (mA/V)

Use a shielded twisted pair with the shield grounded at the signal source for connecting Voltage source. Connect common (-) to terminal 29 (25) and the signal (+) to terminal 30 (26), as shown in Figure 10.2 (b). The DC Current source (mA) is also connected in the similar way.

TEMP. ALARM : Temperature Alarm Relay Output (Terminals 3, 4)

TEMP. ALARM : Temperature Alarm SSR Output (Terminals 18, 17)

RHALARM : RH Alarm Relay Output (Terminals 5, 6)

Figure 10.3

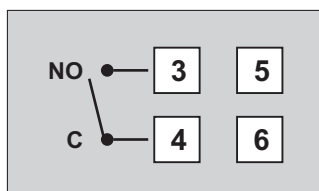

Temp. Alarm / RH Alarm Relay

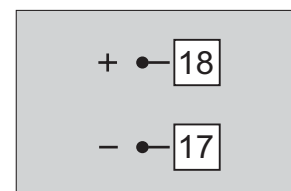

Temp. Alarm SSR

TEMP. CTRL : Temperature Control Relay Output (Terminals 7, 8, 9)

TEMP. CTRL : Temperature Control SSR Output (Terminals 20, 19)

RH CTRL : RH Control Relay Output (Terminals 10, 11, 12)

RH CTRL : RH Control SSR Output (Terminals 16, 15)

Figure 10.4

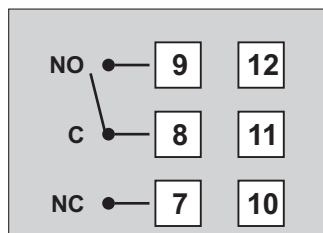

Temp. Control / RH Control Relay

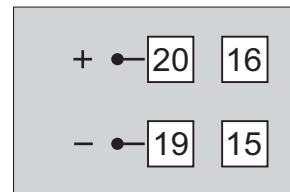

Temp. Control / RH Control SSR

Relay Output

Potential-free Relay changeover contacts NO (Normally Open) and C (Common) rated 10A/240 VAC (resistive load).

SSR Output

Connect (+) and (-) terminals of SSR to (+) and (-) terminals of controller, respectively. Use Zero-Crossover, 3 to 30 VDC operated SSR.

EXC 5/12/24VDC : Excitation Voltage for Transmitters (Terminal : 31, 27)

The Controller is supplied with either 5 or 12 or 24VDC @ 30 mA power source. This is primarily meant for exciting 2-wire or 4-wire Current / Voltage output transmitters. Please note that only the Source terminal (positive) is provided on the back panel termination. The Sensor negative terminal is used as Return terminal (ground) for excitation output.

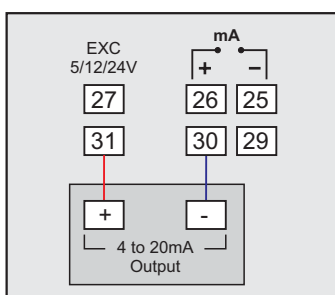

2-wire Current Transmitter (5/12/24VDC Supply)

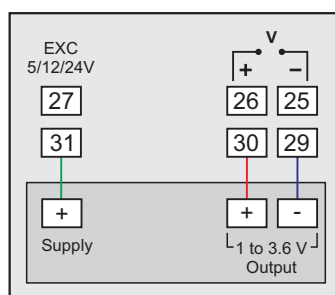

3-wire Voltage Transmitter (5/12/24VDC Supply)

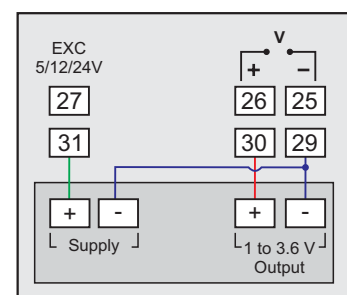

4-wire Voltage Transmitter (5/12/24VDC Supply)

TEMPERATURE RETRANSMISSION OUTPUT (Terminals : 23, 22)

%RH RETRANSMISSION OUTPUT (Terminals : 22, 21)

The retransmission output is either DC Current (0/4-20 mA) or DC Voltage (0-5/10 V) depending on the module fitted. The terminal labeled '+' & '-' are the Current/Voltage source output and return, respectively.

Figure 10.5 : mA / V Output

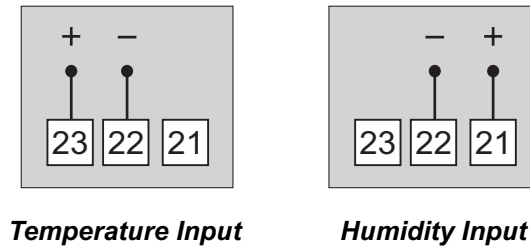

ALARMACKNOWLEDGMENT (Terminals 14, 13)

Potential-free contact closure input terminals are provided for connecting a remote (external) button for the purpose of issuing an Alarm Acknowledgment command. An 'OPEN' to 'CLOSE' change-over of the contacts acts as an Acknowledgment command. Refer figure 10.6.

Figure 10.6

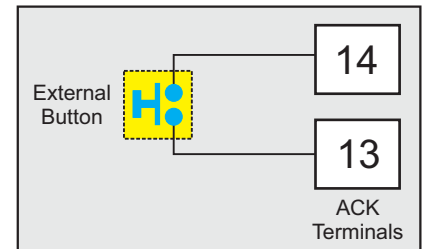

RS485 : Serial Communication Port (Terminals 33, 32)

Connect terminal 33 and 32 of the controller to (+) and (-) RS485 terminals of the Master device.

To ensure reliable operation of the Serial Communication Link (without data corruption due to line noise or reflections), use a pair of twisted wires inside screened cable with the terminating resistor (100 to 150 Ohms) at one end, as shown in Figure 10.7 below.

Figure 10.7

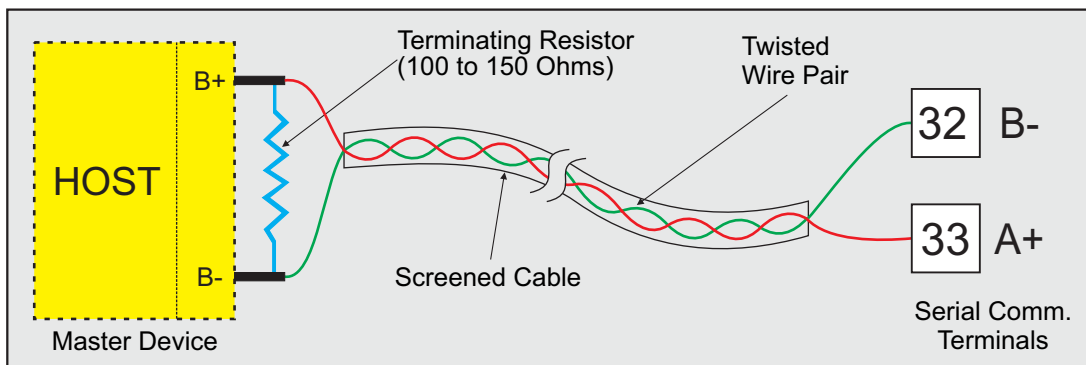

85~264 VAC : Power Supply (Terminals 1, 2)

The controller is supplied with power connections suited for 85 to 264 VAC line supply. Use well-insulated copper conductor wire of the size not smaller than 0.5mm² for power supply connections. Connect Line (Phase) supply line to terminal 1 and the Neutral (Return) supply line to terminal 2 as shown in Figure 10.8 below. The controller is not provided with fuse and power switch. If necessary, mount them separately. Use a time lag fuse rated 1A@240 VAC.

Figure 10.8

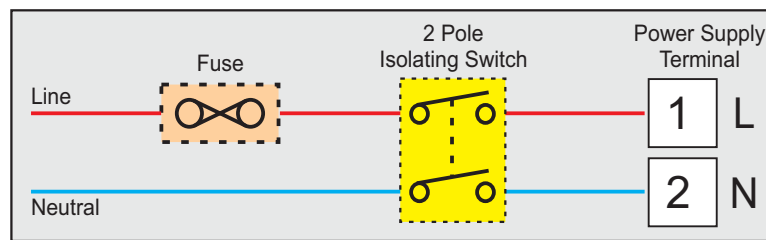

APPENDIX - A

DC LINEAR SIGNAL INTERFACE

This appendix describes the parameters required to interface process transmitters that produce Linear DC Voltage (mV/V) or Current (mA) signals in proportion to the measured process values. A few examples of such transmitters are;

1. Pressure Transmitter producing **4 to 20 mA** for **0 to 5 psi**
2. Relative Humidity Transmitter producing **1 to 4.5 V** for **5 to 95 %RH**
3. Temperature Transmitter producing **0 to 20 mA** for **-50 to 250 °C**

The instrument (indicator/controller/recorder) that accepts the linear signal from the transmitter computes the measured process value by solving the mathematical equation for Straight-Line in the form:

$$Y = mX + C$$

Where;

- X : Signal Value from Transmitter
- Y : Process Value Corresponding to Signal Value X
- C : Process Value Corresponding to X = 0 (Y-intercept)
- m : Change in Process Value per unit Change in Signal Value (Slope)

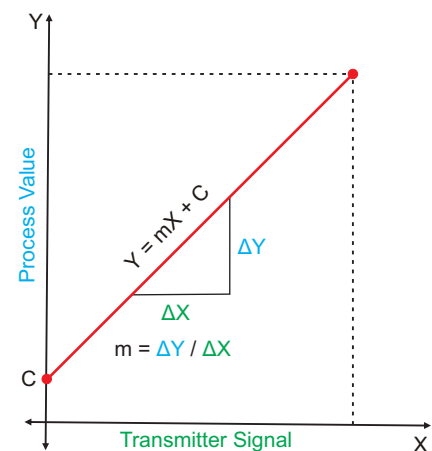

As is evident from the aforementioned transmitter examples, different transmitters produce signals varying both in type (mV/V/mA) and range. Most PPI instruments, thus, provide programmable Signal Type and Range to facilitate interface with a variety of transmitters. A few industry standard signal types and ranges offered by the PPI instruments are: 0-50mV, 0-200mV, 0-5 V, 1-5 V, 0-10V, 0-20 mA, 4-20 mA, etc.

Also, the output signal range (e.g. 1 to 4.5 V) from different transmitters corresponds to different process value range (e.g. 5 to 95 %RH); the instruments thus also provide facility for programming the measured process value range with programmable Resolution.

The linear transmitters usually specify two signal values (Signal Low and Signal High) and the corresponding Process Values (Range Low and Range High). In the example Pressure Transmitter above; the Signal Low, Signal High, Range Low & Range High values specified are: 4 mA, 20 mA, 0 psi & 5 psi, respectively.

In summary, the following 6 parameters are required for interfacing Linear Transmitters:

1. Input Type : Standard DC Signal Type in which the transmitter signal range fits (e.g. 4-20 mA)
2. Signal Low : Signal value corresponding to Range Low process value (e.g. 4 mA)
3. Signal High : Signal value corresponding to Range High process value (e.g. 20 mA)
4. PV Resolution : Resolution (least count) with which to compute process value (e.g. 0.01)
5. Range Low : Process value corresponding to Signal Low value (e.g. 0.00 psi)
6. Range High : Process value corresponding to Signal High value (e.g. 5.00 psi)

The following examples illustrate appropriate parameter value selections.

Example 1: Pressure Transmitter producing **4 to 20 mA** for **0 to 5 psi**

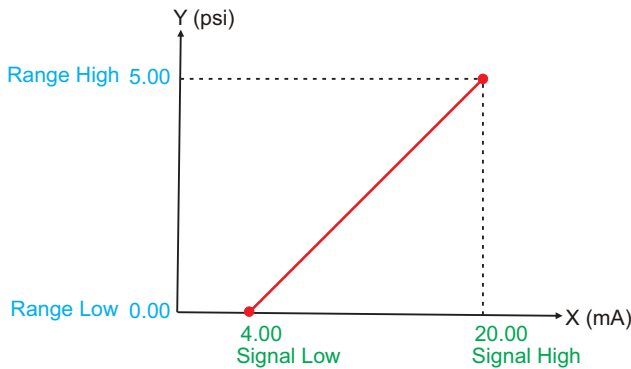

Presume the pressure is to be measured with 0.01 Resolution, that is 0.00 to 5.00 psi.

Input Type	: 4-20 mA
Signal Low	: 4.00 mA
Signal High	: 20.00 mA
PV Resolution	: 0.01
Range Low	: 0.00
Range High	: 5.00

Example 2: Relative Humidity Transmitter producing **1 to 4.5 V** for **5 to 95 %RH**

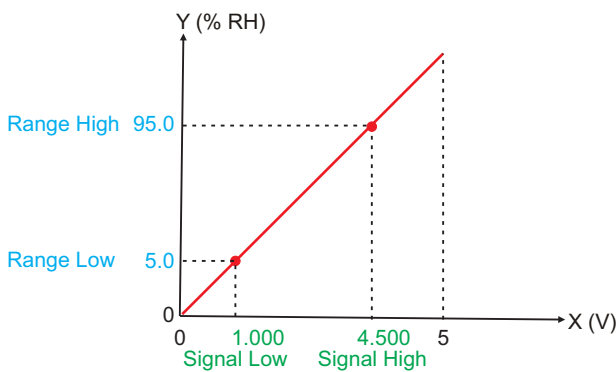

Presume the humidity is to be measured with 0.1 Resolution, that is 0.0 to 100.0 %.

Input Type	: 0-5 V
Signal Low	: 1.000 V
Signal High	: 4.500 V
PV Resolution	: 0.1
Range Low	: 5.0
Range High	: 95.0

Example 3: Temperature Transmitter producing **0 to 20 mA** for **-50 to 250 °C**

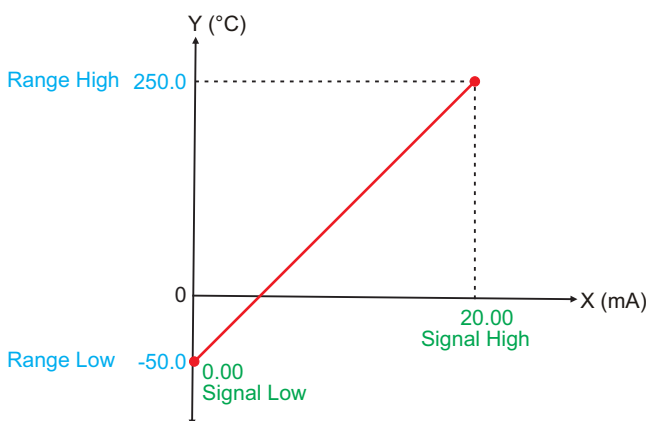

Presume the Temperature is to be measured with 0.1 Resolution, that is -50.0 to 250.0°C.

Input Type	: 0-20 mA
Signal Low	: 0.00 mA
Signal High	: 20.00 mA
PV Resolution	: 0.1
Range Low	: -50.0
Range High	: 250.0



APPENDIX - B PROCESS ALARMS

Definition & Purpose

The process alarm is an event generated and triggered by the process monitoring / controlling instrument in response to the process value deviation from a preset limit. The purpose is to alert the operator of an abnormal process behavior that could result in physical and economic loss. The process alarms are thus implemented to ensure normal and safe process operation.

The alarm system continuously monitors the process signal (such as one representing Temperature, Relative Humidity, Pressure or Flow) and compares it against preset limits (also called Set-points). If the process signal moves to undesirable high or low level, the alarm activates a relay output to warn of trouble, provide on-off control or institute an emergency shutdown.

Hysteresis

The Alarm relay triggers upon crossing the preset limit (set-point) and usually remains active until the process signal re-crosses the limit and passes out of a dead band called Hysteresis. The dead band is usually adjustable and determines at what point the alarm relay resets to its non-alarm state.

The hysteresis prevents the alarm relay from chattering on & off should the process signal oscillate up and down around the alarm limit, as shown in the figure B.1(a) and figure B.1(b) below.

Figure B.1 (a) : Alarm without Hysteresis

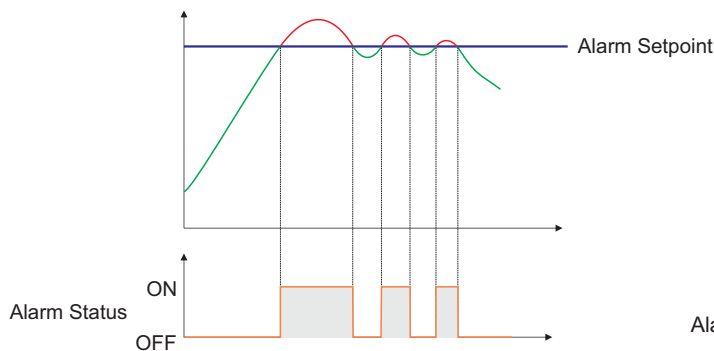
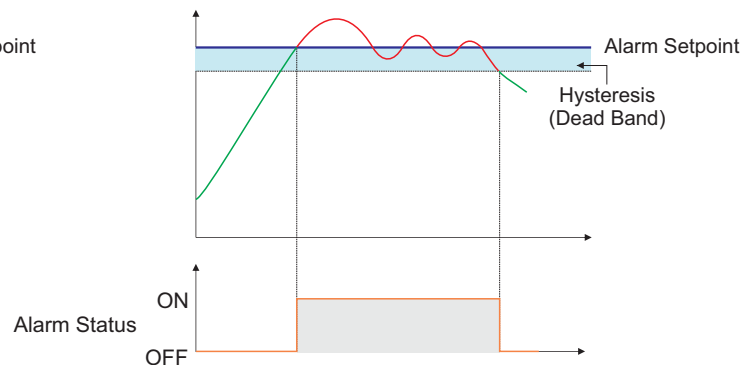

Figure B.1 (b) : Alarm with Hysteresis



Latched Alarm

If the alarm is programmed as Latched Alarm, the alarm relay cannot reset automatically upon removal of alarm condition. The relay latches in the alarm condition until manually reset by the operator by pressing “Acknowledge” button. The purpose of a latched alarm is to ensure that the occurrence of an alarm does not go unnoticed.

Direct / Reverse Relay Activation

If the alarm relay is programmed to operate Direct in response to the Alarm status, the relay switches ON upon alarm activation and switches OFF upon reset. The direct relay activation is used for triggering an audio/visual alert device like Siren, Hooter, Warning Light, Bell, etc., for attracting attention of the operator.

If the alarm relay is programmed to operate Reverse in response to the Alarm status, the relay switches OFF upon alarm activation. The relay activation in this case is used to shutdown the process power. Under non-alarm condition the relay remains ON to power to the process.

Alarm Inhibit

In many cases it is desired that the alarm system activates only once the process signal reaches / crosses the preset alarm set-point from a known condition such as process startup or change in set-point. The alarm inhibit feature can be enabled for this purpose.

The figure B.2 below depicts a heating system wherein the temperature is to be raised to 800°C and then to be monitored to remain within $\pm 10^\circ\text{C}$. Upon cold start (Process Value near Ambient), the system temperature is obviously outside alarm band and will generate alarm if inhibit feature is not enabled.

The inhibit feature suppresses the alarm upon power-up until the process value rises above the Low Limit at 790°C. The alarm system is now activated and will trigger the alarm relay should the temperature deviate outside the band.

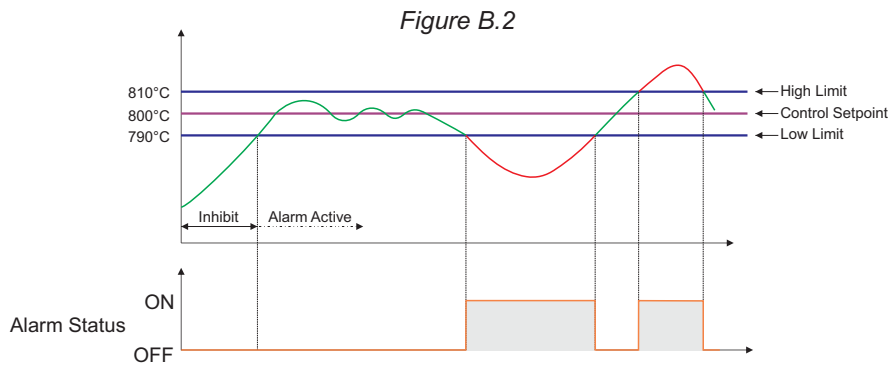

ALARM TYPES

The alarm type (together with set limit) defines the nature of deviation(s) to be notified such as process value rising above or falling below a Set Limit. There are 4 commonly used alarm types described below.

1. Process Low

In this alarm type, the process value is monitored against falling below a set limit called the Low Alarm Set-point. An alarm is generated if the process value is detected lower than the set limit.

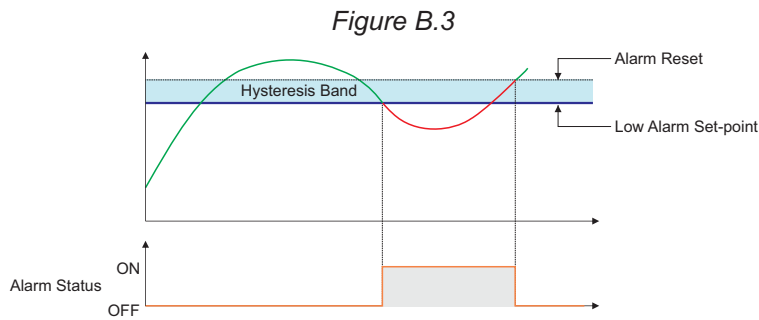

2. Process High

In this alarm type, the process value is monitored against rising above a set limit called the High Alarm Set-point. An alarm is generated if the process value is detected higher than the set limit.

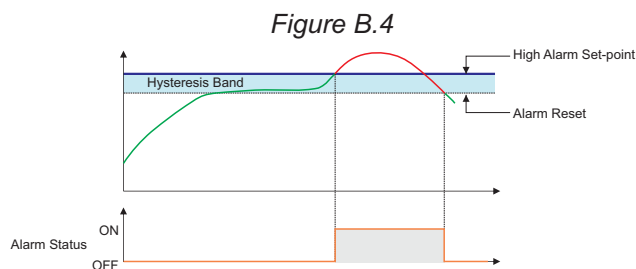

3. Deviation Band

This alarm type is implemented in the system where the process value is required to be maintained at a desired set value, called Control Set-point, with a permissible deviation in either direction - above or below. The permissible deviation is set as an offset value called Deviation Band.

A Negative offset value sets a **Low Limit** derived by subtracting the Deviation Band value from the Control Set-point. The process value is monitored against falling below the Low Limit. An alarm is generated if the process value is detected lower than this limit.

A Positive offset value sets an **High Limit** by adding the Deviation Band value to the Control Set-point. The process value is monitored against rising above the High Limit. An alarm is generated if the process value is detected higher than this limit.

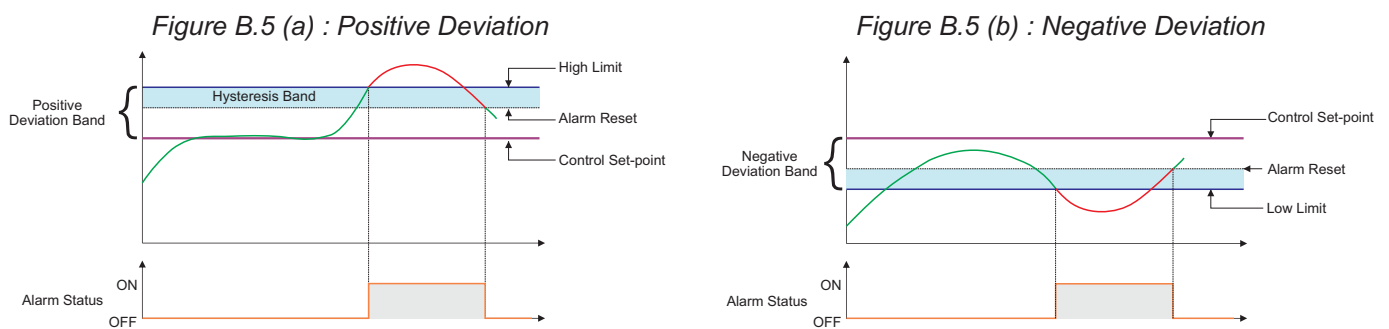

4. Window Band



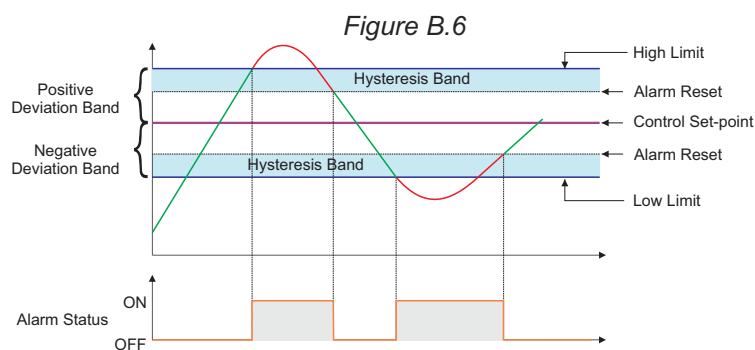

This alarm type is implemented in the system where the process value is required to be maintained at a desired set value, called Control Set-point, with a symmetric permissible deviation in both directions - above and below. The symmetric permissible deviation is set as an offset value called Window Band.

The **Low Limit** is derived by subtracting the Window Band value from the Control Set-point. The process value is monitored against falling below the Low Limit. An alarm is generated if the process value is detected lower than this limit.

The **High Limit** is derived by adding the Window Band value to the Control Set-point. The process value is monitored against rising above the High Limit. An alarm is generated if the process value is detected higher than this limit.



Process Precision Instruments (An ISO 9001 : 2008 Company)

 101, Diamond Industrial Estate, Navghar, Vasai Road (E), Dist. Palghar - 401210, Maharashtra, India
 Sales : 8208199048 / 8208141446 Support : 07498799226 / 08767395333
 sales@ppiindia.net  www.ppiindia.net