

HumiTherm-cS Pro

Advanced Temperature + Humidity Programmable Controller with Alarm & Retransmission Outputs

Operation Manual

This brief manual is primarily meant for quick reference to wiring connections and parameter searching. For more details on operation and application; please log on to www.ppiindia.net

PPI

101, Diamond Industrial Estate, Navghar, Vasai Road (E), Dist. Palghar - 401 210.
 Sales : 8208199048 / 8208141446
 Support : 07498799226 / 08767395333
 E: sales@ppiindia.net, support@ppiindia.net

Oct 2024

OPERATOR PAGE AND PARAMETERS : PAGE 0

Parameters	Settings (Default Value)
Standby Stby	none None both Both 0C Temp rh Humidity (Default : None)
Select Channel SEL	0C Temp rh Humidity (Default : Temp)
Control Setpoint CnSP	Setpoint Low Limit to Setpoint High Limit (Default : 0.0)
Temperature or RH Alarm-1 Setpoint R1SP	
Temperature or RH Alarm-2 Setpoint R2SP	

ALARM PARAMETERS : PAGE-10

Parameters	Settings (Default Value)
Select Channel SEL	0C Temp rh Humidity (Default : Temp)
Alarm-1 Type R1Ty	none None P_Lo Process Low P_Hi Process High (Default : None)
Alarm-1 Hysteresis R1Hy	0.2 to 99.9 (Default : 2.0)
Alarm-1 Inhibit R1h	no No YES Yes (Default : Yes)
Alarm 2 Type R2Ty	The parameter descriptions and settings are the same as that for Alarm-1.
Alarm-2 Hysteresis R2Hy	
Alarm-2 Inhibit R2h	

CONTROL PARAMETERS : PAGE 11

Parameters	Settings (Default Value)
Select Channel SEL	0C Temp rh Humidity (Default : Temp)
Control Action CAct	OnOff On-Off PID PID (Default : PID)
Control Mode tYPE	dhUm De-hum hUm Hum (Default : Hum)
Setpoint Low Limit SPLo	Temp = -199.9°C to SP.Hi RH = 0.0% to SP.Hi (Default : 0)
Setpoint High Limit SPHi	Temp = SP.Lo to 600.0°C RH = SP.Lo to 100.0% (Default : 100)
Heat/humidification Power Low Limit PL	0.0% to Power High Limit (Default : 0.0)
Heat/humidification Power High Limit PH	Power Low Limit to 100.0% (Default : 100.0)
Proportional Band (Cool Pre-dominant Zone) PbC	For Temp = 0.1 to 999.9°C For RH = 0.1 to 999.9% (Default : 50.0)
Integral Time (Cool Pre-dominant Zone) ItC	1 to 3600 Seconds (Default : 100 sec.)
Derivative Time (Cool Pre-dominant Zone) dtC	1 to 600 Seconds (Default : 16 sec.)
Proportional Band (Heat Pre-dominant Zone) Pb	For Temp = 0.1 to 999.9°C For RH = 0.1 to 999.9% (Default : 50.0)
Integral Time (Heat Pre-dominant Zone) It	1 to 3600 Seconds (Default : 100 sec.)
Derivative Time (Heat Pre-dominant Zone) dt	1 to 600 Seconds (Default : 16 sec.)
Cycle Time Ct	0.5 to 100.0 Seconds (in steps of 0.5 secs.) (Default : 10.0 sec.)
Hysteresis HYSt	0.1 to 999.9 (Default : 2.0)

INPUT CONFIGURATION PARAMETERS : PAGE 12

Parameters	Settings (Default Value)																					
Select Channel SEL	0C Temp rh Humidity (Default : Temp)																					
Input Type InPt	Refer Table 1 (Default) For Temp. : RTD, For RH : 0 to 5.0)																					
Signal Low SLo	<table border="1"> <thead> <tr> <th>Input Type</th> <th>Settings</th> <th>Default</th> </tr> </thead> <tbody> <tr> <td>0 to 20mA</td> <td>0.00 to Signal High</td> <td>0.00</td> </tr> <tr> <td>4 to 20mA</td> <td>4.00 to Signal High</td> <td>4.00</td> </tr> <tr> <td>0 to 1.25 V</td> <td>0.00 to Signal High</td> <td>0.00</td> </tr> <tr> <td>0 to 5 V</td> <td>0.000 to Signal High</td> <td>0.000</td> </tr> <tr> <td>0 to 10 V</td> <td>0.00 to Signal High</td> <td>0.00</td> </tr> <tr> <td>1 to 5 V</td> <td>1.000 to Signal High</td> <td>1.000</td> </tr> </tbody> </table>	Input Type	Settings	Default	0 to 20mA	0.00 to Signal High	0.00	4 to 20mA	4.00 to Signal High	4.00	0 to 1.25 V	0.00 to Signal High	0.00	0 to 5 V	0.000 to Signal High	0.000	0 to 10 V	0.00 to Signal High	0.00	1 to 5 V	1.000 to Signal High	1.000
Input Type	Settings	Default																				
0 to 20mA	0.00 to Signal High	0.00																				
4 to 20mA	4.00 to Signal High	4.00																				
0 to 1.25 V	0.00 to Signal High	0.00																				
0 to 5 V	0.000 to Signal High	0.000																				
0 to 10 V	0.00 to Signal High	0.00																				
1 to 5 V	1.000 to Signal High	1.000																				
Signal High SHi	<table border="1"> <thead> <tr> <th>Input Type</th> <th>Settings</th> <th>Default</th> </tr> </thead> <tbody> <tr> <td>0 to 20mA</td> <td>20.00 to Signal Low</td> <td>20.00</td> </tr> <tr> <td>4 to 20mA</td> <td>20.00 to Signal Low</td> <td>20.00</td> </tr> <tr> <td>0 to 1.25 V</td> <td>1.250 to Signal Low</td> <td>1.250</td> </tr> <tr> <td>0 to 5 V</td> <td>5.000 to Signal Low</td> <td>5.000</td> </tr> <tr> <td>0 to 10 V</td> <td>10.00 to Signal Low</td> <td>10.00</td> </tr> <tr> <td>1 to 5 V</td> <td>5.000 to Signal Low</td> <td>5.000</td> </tr> </tbody> </table>	Input Type	Settings	Default	0 to 20mA	20.00 to Signal Low	20.00	4 to 20mA	20.00 to Signal Low	20.00	0 to 1.25 V	1.250 to Signal Low	1.250	0 to 5 V	5.000 to Signal Low	5.000	0 to 10 V	10.00 to Signal Low	10.00	1 to 5 V	5.000 to Signal Low	5.000
Input Type	Settings	Default																				
0 to 20mA	20.00 to Signal Low	20.00																				
4 to 20mA	20.00 to Signal Low	20.00																				
0 to 1.25 V	1.250 to Signal Low	1.250																				
0 to 5 V	5.000 to Signal Low	5.000																				
0 to 10 V	10.00 to Signal Low	10.00																				
1 to 5 V	5.000 to Signal Low	5.000																				
Range Low rLo	-199.9 to 999.9 (Default : 0.0)																					
Range High rHi	-199.9 to 999.9 (Default : 100.0)																					
Offset OFSt	-50.0 to 50.0 (Default : 0.0)																					
Filter Filt	0.5 to 60.0 Seconds (in steps of 0.5 Seconds) (Default : 2.0 sec.)																					

Parameters	Settings (Default Value)
Tune Command tUNE	no No YES Yes (Default : No)
Standby Selection Permission Stby	dSbL Disable EnbL Enable (Default : Disable)

SUPERVISORY PARAMETERS : PAGE 13

Parameters	Settings (Default Value)
Control / alarm Set-point Adjustment Permission SPOP	dSbL Disable EnbL Enable (Default : Disable)
Digital Input Function dIFC	none None LLOY Water Level ARCh Alarm ACK (Default : None)
Water Level Logic WLLG	OPEN Open as Low CLoS Close as Low (Default : Open as Low)
Device Slave ID Id	1 to 127 (Default : 1)
Baud Rate BAUD	4800 9600 19200 (Default : 9.6)
Parity PARi	none None EvEn Even Odd Odd (Default : Even)
Serial Write Permission Coñ.E	no No YES Yes (Default : No)

Parameters	Settings (Default Value)
Select Channel SEL	0C Temp rh Humidity (Default : Temp)
Retransmission Output Type rEt.o	0-20 0 - 20mA 4-20 4 - 20mA 0-5 0 - 5 V 0-10 0 - 10 V (Default : 4 - 20mA)

Parameters	Settings (Default Value)
Retransmission Low rEt.L	Input Type Minimum Range to Input Type Maximum Range (Default : 0.0)
Retransmission High rEt.H	Input Type Minimum Range to Input Type Maximum Range (Default : 100.0)

COMPRESSOR SETTING PARAMETERS : PAGE 17

Parameters	Settings (Default Value)
Compressor Output Mode CPOP	OFF OFF On ON AUTO AUTO (Default : Auto)
Compressor Strategy CPSt	SPoC Dry Bulb SP PwPC Dry Bulb PV Pwrh %RH PV (Default : Dry Bulb SP)
Boundary Set-point bSP	Temp. SP Low Limit to Temp. SP High Limit (Default : 45.0)
Compressor Set-point CPSP	0.0 to 50.0 (Default : 0.2)
Compressor Hysteresis CPHY	0.1 to 25.0 (Default : 0.2)
Compressor Time Delay t.dLY	0.00 to 10.00 Min (in steps of 5 secs.) (Default : 0 Sec.)

FRONT PANEL LAYOUT

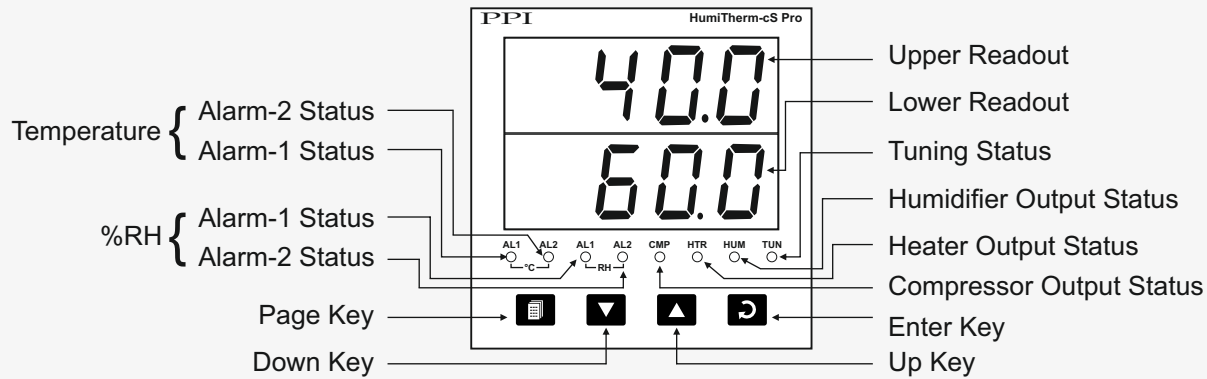

Keys Operation

Symbol	Key	Function
	PAGE	Press to enter or exit set-up mode.
	DOWN	Press to decrease the parameter value. Pressing once decreases the value by one count; keeping pressed speeds up the change.
	UP	Press to increase the parameter value. Pressing once increases the value by one count; keeping pressed speeds up the change.
	ENTER	Press to store the set parameter value and to scroll to the next parameter on the PAGE.

ELECTRICAL CONNECTIONS

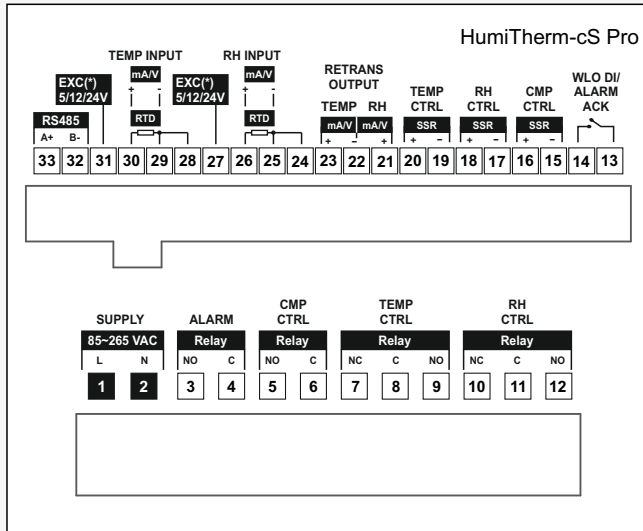

TABLE- 1

Option	Range (Min. to Max.)	Resolution
3-wire, RTD Pt100	-199.9 to +600.0°C	0.1°C
0 to 20mA DC current		
4 to 20mA DC current		
Reserved (Default : 0 to 20mV)		
0 to 1.25V DC voltage	-199.9 to 999.9 units	0.1 units
0 to 5.0V DC voltage		
0 to 10.0V DC voltage		
1 to 5.0V DC voltage		

PV Error Indications for Dry Bulb Temperature

Message	Error Type
	Over-range Dry Bulb Temp. above Max. Range
	Under-range Dry Bulb Temp. below Min. Range
	Sensor Open Dry Bulb Sensor (RTD) Broken / Open

PV Error Indications for Relative Humidity (RH)

Message	Error Type	Cause
	Over-range	Wet Bulb Temperature above Max. Range
	Under-range	Wet Bulb Temperature below Min. Range
	Sensor Open	Wet Bulb Sensor (RTD) Broken / Open
	RH Error	This error is indicated in the following cases : <ul style="list-style-type: none"> Dry Bulb Temperature above 102.0°C. Dry Bulb Temperature below -20.0°C. Wet Bulb depression beyond: 50.0°C for Dry Bulb Temperature above 0°C 5.6°C for Dry Bulb Temperature below 0°C
	Display Freezes To 100.0%	This error is indicated in the following cases : <ul style="list-style-type: none"> Wet-Bulb Temperature exceeds Dry-Bulb Temperature. Computed % RH above 100.0%.
	Display Freezes To 0.0%	Computed % RH is below 0.0%.