

PC Interface with 21 CFR Software

Dot-Matrix Printer Interface

GSM Module for SMS Alerts

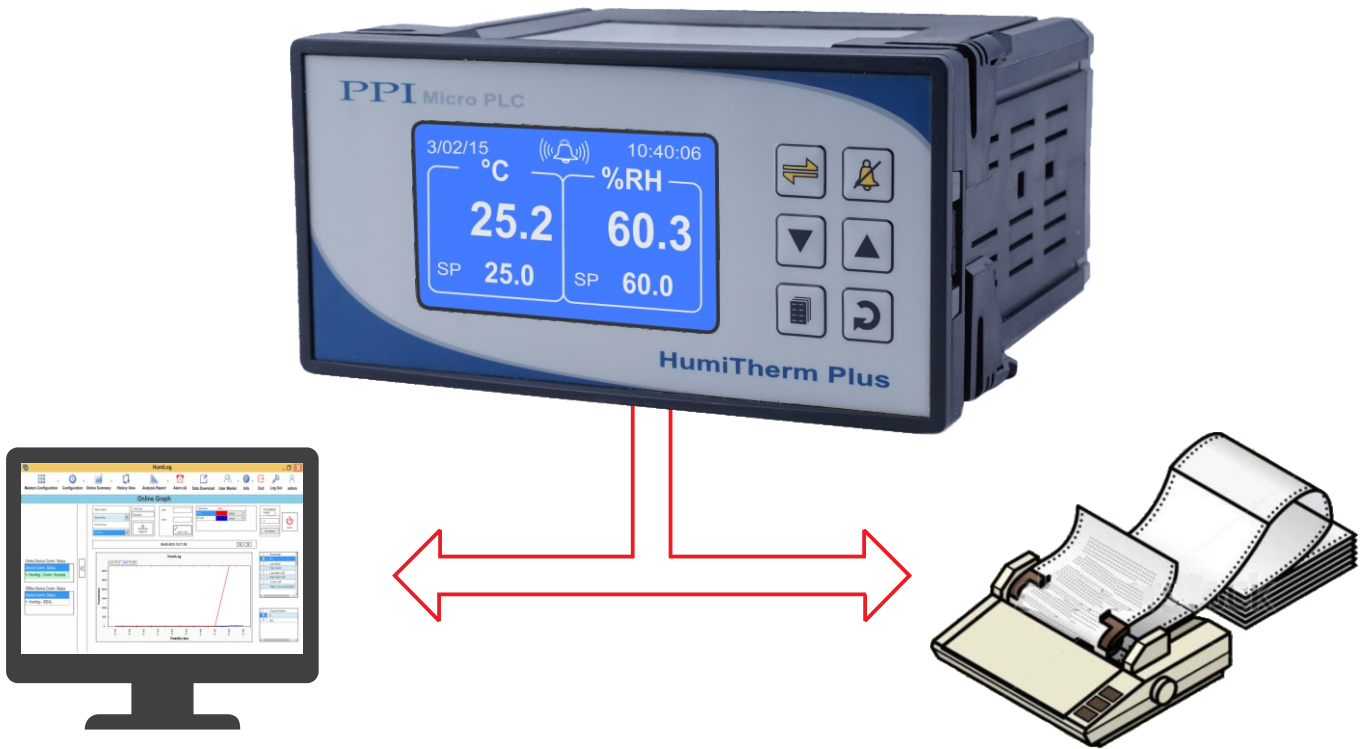

Available Versions

- ❖ Controller + RS485 MODBUS (No Recording)
- ❖ Controller + Recorder + PC Software
- ❖ Controller + Recorder + Printer
- ❖ Controller + Recorder + PC Software + Printer
- ❖ Controller + Recorder + PC Software + GSM Module

Features

- 160 X 80 Monochrome Graphic Display for Comprehensive Process Information
- Universal Input for Temperature & %RH with In-built Excitation Voltage
- Independent Self Tune PID Control Loops for Temperature & %RH
- SSR Drive Control Output for Heating, Humidification, Compressor & Alarm
- Compressor Switching with Programmable Time Delay
- Intelligent Door-Open Sensing & Alarm
- Smart Water Level Detection with Alarm
- In-built Huge Memory for Data Logging
- PV and Event Data Recording with Date / Time Stamping
- Serial Port for PC Interface with 21 CFR Compliance Software
- **Optional** Printer Interface Module for Direct On/Off-Line Printing with PC Configurable Header / Footer
- **Optional** GSM Interface Module for SMS Alerts

Specifications

Display							
Graphic LCD	Monochrome Graphic LCD						
Viewing area & Resloution	72x40 mm and 160x80 pixels						
Keys							
Type	6 Tactile Switches						
Functions	<table border="0" style="width: 100%;"> <tr> <td style="width: 33%;">SCROLL</td> <td style="width: 33%;">PAGE</td> <td style="width: 33%;">ALARM ACK</td> </tr> <tr> <td>UP</td> <td>DOWN</td> <td>ENTER</td> </tr> </table>	SCROLL	PAGE	ALARM ACK	UP	DOWN	ENTER
SCROLL	PAGE	ALARM ACK					
UP	DOWN	ENTER					
Analog Inputs							
Temperature (User Programmable)	RTD Pt100, 3 wire DC Linear : 0-20 mA, 4-20 mA 0-5 V, 0-10 V, 1-5 V						
Humidity (%RH) (User Programmable)	DC Linear : 0-20 mA, 4-20 mA 0-5 V, 0-10 V, 1-5 V						
Accuracy	RTD Pt100 : ± 0.25% of reading ± 1°C DC Volts/Current : ± 0.25% of reading ± 1 LSD						
Display Resolution	Temperature : 0.1 Fixed %RH : 0.1 Fixed						
Zero Offset	User Adjustable over Full Range for Both Temperature & %RH						
ADC	16 Bit (±32,768 Counts), Sigma-Delta ($\Sigma\Delta$)						
Sampling Time	500mS (2 Samples per Second)						
Common Mode Rejection	> 100dB at 50/60 Hz						
Signal Conditioning	L-C Analog Filter on Each Input						
Excitation Voltage							
Ratings	5 V @ 15 mA 24 V @ 60 mA, Optional						
Boiler (Steam) Water Level Monitoring							
Input	<ul style="list-style-type: none"> Digital Input (Potential-free Contacts) from Float Switch or Thermostat Additional Digital Input for Float with Dual Switches (Low/High Levels or Low/Very-Low Levels) 						
Function	Alarm Alert & Automatic Boiler Heater Cut-off on Low Water Level Detection						
Door Status Monitoring							
Input	Digital Input (Potential-free Contacts) from Door Switch						
Function	Alarm Alert on Door Opening for Longer than Set Time						
Mains Power Fail Monitoring							
Input	Digital Input (Potential-free Contacts) from Power Source Switching Gadget (like Relay)						
Function	Alarm Alert & Automatic Cut-off of Air Heater, Boiler Heater & Compressor during Mains Power Fail						

Alarm System	
Process Alarm	Programmable High/Low Process Alarms for Temperature & Humidity
*Door Open Alarm	Alarm on Chamber Door Remaining Open for More than Set Time Period
*Water Level Alarm	Alarm on Boiler Water Level Low Detection
*Mains Fail Alarm	Alarm on Change-over from Mains Power to Alternate Power Source (Battery, Inverter, etc.)
Audio Alert	In-Built Buzzer (Beeper)
Output	SSR Output for Remote Switching of Audio/Visual Gadget on Alarms
Alarm Acknowledge	<ul style="list-style-type: none"> Rear Panel Digital Input for Connecting Remote Alarm Acknowledge (Mute) Button Front Panel Alarm Acknowledge (Mute) Key
Heat Control	
Type	Self Tune PID
Control Parameters	Proportional Band, Integral Time, Derivative Time, Cycle Time
Output	SSR Drive Voltage
Humidity Control	
Type	Self Tune PID
Control Parameters	Proportional Band, Integral Time, Derivative Time, Cycle Time
Output	SSR Drive Voltage
Compressor Control	
Type	On-Off with Programmable Time Delay & Hysteresis
Control Strategy (Programmable)	<ol style="list-style-type: none"> Can be Switched ON-OFF Manually. Based on Programmable Temperature SP Threshold. Compressor is ON for Temperature SP Below Threshold & OFF Above. Cool Control. Switches ON-OFF Based on Temperature PV & SP
Output	SSR Drive Voltage
Data Recording	
Storage Device	In-built Micro SD Card (2 GB)
Record Capacity	38,00,000
Recording Interval	User Programmable
Recording Data (Date/Time Stamped)	<ul style="list-style-type: none"> Process Values Measured Temperature, Measured Humidity Events Power-up, Process Value Alarm Toggle Change in Temperature SP, Change in Humidity SP Change in Date/Time Settings, Change in Recording Interval Chamber Door Open/Close, Boiler Water Level Low Mains Power Fail/Resumption

*User Configurable. Can be disabled if not required.

Power Supply	
Type	Switch Mode (SMPS)
Line Voltage	18 ~ 32 VDC (nominal 24 VDC @ 1A max.)
Consumption	5VA Max
Physical	
Mounting	Plug-in with Panel Mounting Clamps
Overall Dimensions	80 (H) X 160 (W) X 144 (D), mm
Panel Cutout	78 (H) X 154 (W), mm
Terminals	3.5 mm Pitch, Pluggable Terminal Blocks
Environmental	
Operating Ambient	0~55°C & 5~90%RH Non-condensing
Storage Temperature	-10 to +70 °C
EMC Standards	EN50081-2 & EN 50082-2 Generic Stds for Industrial Environment
Safety Standards	Meets EN61010, Installation Catagory II
Atmospheres	Not Suitable for use in Corrosive or Explosive Atmospheres. The Panel in which the Instrument is Mounted must be free of Electrically Conductive Pollution.

Back Panel Terminations

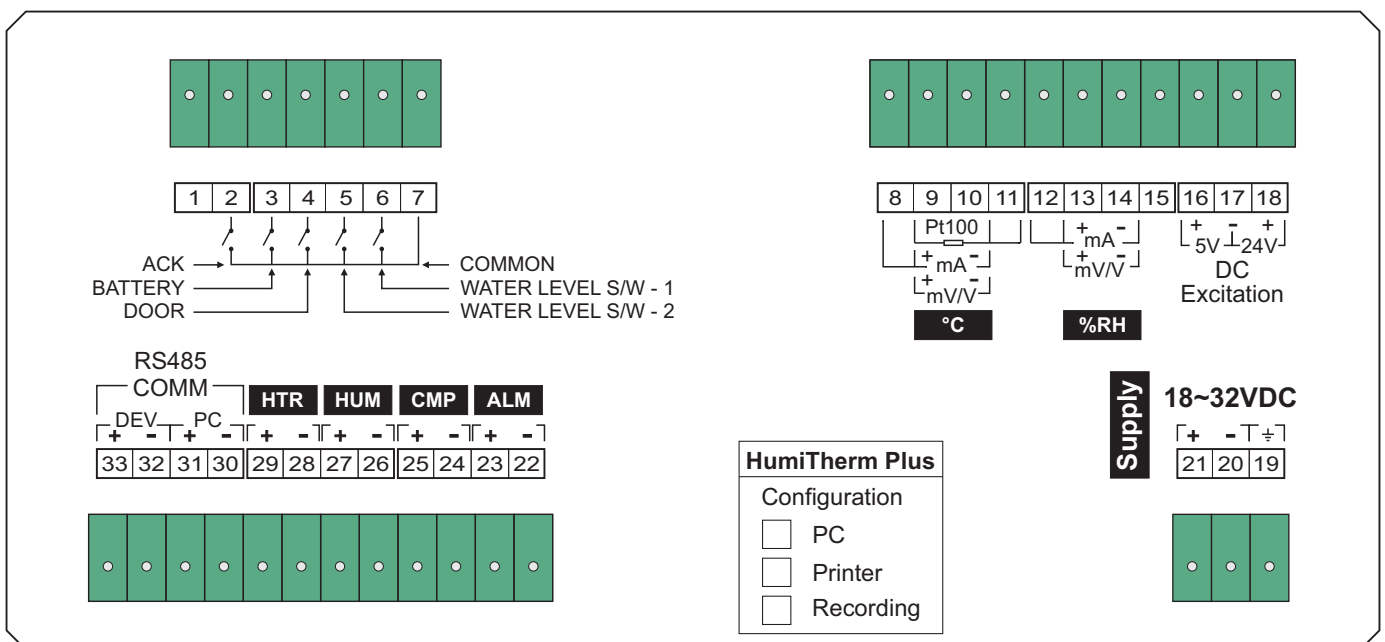

PC Interface with 21 CFR Compliant Software

Supported Operating Systems (OS)	<ul style="list-style-type: none"> • Windows Vista • 32 bit / 64 bit Windows 8 • Windows 7 • 32 bit / 64 bit Pentium Dual Core
Minimum PC Configuration Requirements	<ul style="list-style-type: none"> • 2.8 GHz Clock Speed • 40 GB Hard Disk • 2 GB RAM
PC Software Features (USFDA 21 CFR Part 11 Compliant)	<ul style="list-style-type: none"> • Supports Multiple Chambers on Single Installation • Auto Start-up on PC Power-up • Online Display of Process Values & Stored Records in Graphical & Tabular Forms with Alarm Indications • SMS and/or Email Alerts on Alarm Conditions • Mean Kinetic Temperature (MKT) Computation • Automatic Periodic Downloading of Records Stored in Controller • Access Control According to Authority Level • User Actions with Signing & Authorization • Automatic Password Expiry • Manual & Auto Back-up Facility with Archiving • Data Log Reports with User Configurable Title, Footer & Header • Data Log Report, Alarm Log Report, History Graph & Audit Trail Report in PDF & EXCEL formats • Audit Trail History of Critical Events & User Actions

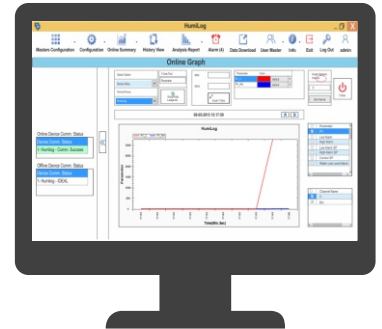

Printer Interface (Optional Add-on Device)

Controller Interface Port	RS485 Serial
Printer Interface Port	Centronix (Parallel Interface)
Printer Support	80/132 Column Dot-Matrix (EPSON LX-300-II or Equivalent)
Print Data	Well-Formatted, Date-Time Stamped Process value & Event Records (PC Tool for user Programmable Header & Footer)
Supply Voltage	10~30 VDC (24 VDC Nominal)



GSM Interface (Optional Add-on Device)

Controller Interface Port	RS485 Serial
Frequency Band	Quad (850/900/1800/1900 MHz)
SMS Alert Events	<ul style="list-style-type: none">• High/Low Temperature & Humidity Alarms• Door Open Alarm• Low Boiler Water Level Alarm• Mains Failure Alarm
Information on Request through SMS	Process Values & Process Status
Recipients	Up to 10; User Programmable through SMS by Secured Access
Supply Voltage	10~30 VDC (24 VDC Nominal)



*** The Module does not support Jio SIM Card.**