

4 / 8 / 16 Channel Data Logger + PC Interface

21 CFR Part 11
Compliant
Software

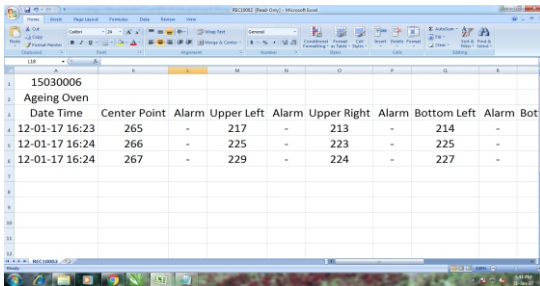

4 / 8 / 16 Channel Data Logger + Pen-Drive Interface



Date Time	Center Point	Alarm Upper Left	Alarm Upper Right	Alarm Bottom Left	Alarm Bot
12-01-17 16:23	265	-	217	-	214
12-01-17 16:24	266	-	225	-	225
12-01-17 16:24	267	-	229	-	227



Features

- 160 X 80 Monochrome Graphic Display & 6 Tactile Keys
- 4 / 8 / 16 Universal Analog Channels
- Each Channel Independently Configurable (Jumper-less) for :
Thermocouples, RTD Pt100, mV, V, mA
- Fast Channel Update Rate : 250 mS per Channel
- Each Channel with Up to 4 Programmable Soft Alarms
- Optional, 4 Common Relay Outputs for Alarms with Front Panel Acknowledgment Key
- Optional 1 or 2 Excitation Voltage Outputs : 5V or 24V (Isolated)
- User Assigned Channel Names for Easy PV Identification
- Huge Data Storage Capacity : Appx. 38,56,000 Records
- Date / Time Stamped Process Value (PV) & Alarm Status Recording for Each Channel
- Continuous or Batch Recording with Programmable Recording Interval
- Event Generated Records : Power-up, Alarm Toggle, RTC / Recording Interval Changed
- Free 21 CFR Part 11 Compliant Software with PC Interface Version
- Easy Data Transfer to PC in Excel Format for Pen-Drive Version
- Supply Voltage : 85 to 264 VAC, 50/60 Hz

Specifications

Operator Interface	
Display	160 X 80 STN Monochrome Graphic LCD
Keys	6 Tactile Switches PAGE, DOWN, UP, ENTER, Alarm ACK/VIEW, Scroll
Sensor Input	
Input Types	Thermocouples : J, K, T, R, S, B, N RTD : Pt100, 3-Wire DC mV : 0 to 80 mV DC Volts : 0 to 1.25V, 0 to 5V, 1 to 5V, 0 to 10V DC mA : 0-20 mA, 4-20 mA
Accuracy	± 0.25% of reading ± 1 LSD
Corrections	<ul style="list-style-type: none"> • Cold-Junction Compensation for Thermocouples (Accuracy Better than ± 0.5°C) • Lead Resistance Compensation for RTD (Upto 22 Ohms in each lead)
Range	Thermocouple & RTD Pt100 : Refer Table-1 DC Volts / Current : ± 30000 Counts
Zero Offset	User Adjustable over Full Range for Each Channel
ADC	16 Bit (± 32,768 Counts), Sigma-Delta (ΣΔ)
Sampling Time	250 mS Per Channel (1 / 2 / 4 Seconds for 4 / 8 / 16 Channels, respectively)
Input Resistance	> 10 MΩ
Common Mode Rejection	> 100dB at 50/60 Hz
Input Protection	ESD : 8KV EFT : 2KV Surge : 1KV
Input Conditioning	First Order Analog R-C Low-Pass Filter
Alarms	
Numbers	4 Independent for Each Channel
Programmable Parameters	Type : Process Low, Process High Logic : Normal, Reverse Hysteresis : 1 to 3000 Unit Counts Inhibit : No, Yes
Outputs (Optional)	Relay Change-over Contacts Relay-1 to Relay-4 Common for Alarm-1 to Alarm-4 of All Channels
Outputs	
Relay	Contact Type : Potential-free Change-over Contacts Contact Rating : 5A Resistive @ 120/240 VAC Contact Life : > 5,00,000 Operations at Rated Voltage / Current
Recording	
Recording Capacity	2 GB Flash Memory (Approx. 38,56,000 Records)
Recording Mode	Continuous, Batch
Recording Interval	Programmable from 1 Sec to 2 Hr : 30 Min : 00 Sec

Power Supply	
Type	Switch Mode (SMPS)
Line Voltage	85 to 264 VAC, 50/60Hz
Consumption	5VA Max
Physical	
Mounting	Plug-in with Panel Mounting Clamps
Overall Dimensions	80 (H) X 160 (W) X 144 (D), mm
Panel Cutout	78 (H) X 154 (W), mm
Terminals	Pluggable Terminal Blocks
Environmental	
Operating Ambient	0 to 55°C & 5 to 90%RH Non-condensing
Storage Temperature	-10 to 70°C
Atmospheres	Not Suitable for use in Corrosive or Explosive Atmospheres. The Panel in which the Instrument is Mounted must be free of Electrically Conductive Pollution.
PC Interface	
Serial Communication	Port : RS485, 2-wire, Half Duplex, Start-Stop Synchronized Slave ID : 1 to 127 Max. Units per Loop : 31 Max. Distance : 1200 Meters
Supported Operating Systems (OS)	<ul style="list-style-type: none"> • Windows Vista • Windows 7 • 32 bit / 64 bit Windows 8 • 32 bit / 64 bit Pentium Dual Core
Minimum PC Configuration Requirements	<ul style="list-style-type: none"> • 2.8 GHz Clock Speed • 2 GB RAM • 40 GB Hard Disk
PC Software Features (USFDA 21 CFR Part 11 Compliant)	<ul style="list-style-type: none"> • Supports Multiple ScanLog on Single Installation • Auto Start-up on PC Power-up • Online Display of Process Values & Stored Records in Graphical & Tabular Forms with Alarm Indications • SMS and/or Email Alerts on Alarm Conditions • Process Value Min / Max Average Computation • Automatic Periodic Downloading of Records Stored in ScanLog • Access Control According to Authority Level • User Actions with Signing & Authorization • Automatic Password Expiry • Manual & Auto Back-up Facility with Archiving • Data Log Reports with User Configurable Title, Footer & Header • Data Log Report, Alarm Log Report, History Graph & Audit Trail Report in PDF & EXCEL formats • Audit Trail History of Critical Events & User Actions

Pen-Drive Interface	
Pen-Drive Support	USB 2.0, Format : FAT, Socket : Type A
File Operation	Read <i>Set.txt</i> file Write .csv files (Data Records)

Table 1 : Temperature Ranges for Thermocouples & RTD

Input Type	Range (Min. to Max.)	Resolution
Type J Thermocouple (Fe-K)	0 to +960°C	1 °C or 0.1 °C (Programmable)
Type K Thermocouple (Cr-Al)	-200 to +1376°C	
Type T Thermocouple (Cu-Con)	-200 to +385°C	
Type R Thermocouple (Pt/Pt-Rh13%)	0 to +1770°C	
Type S Thermocouple (Pt/Pt-Rh10%)	0 to +1765°C	
Type B Thermocouple	0 to +1825°C	
Type N Thermocouple	0 to +1300°C	
3-wire, RTD Pt100	-200 to +600°C	

Back Panel Terminations

4 Channel Without Alarm Relay Outputs

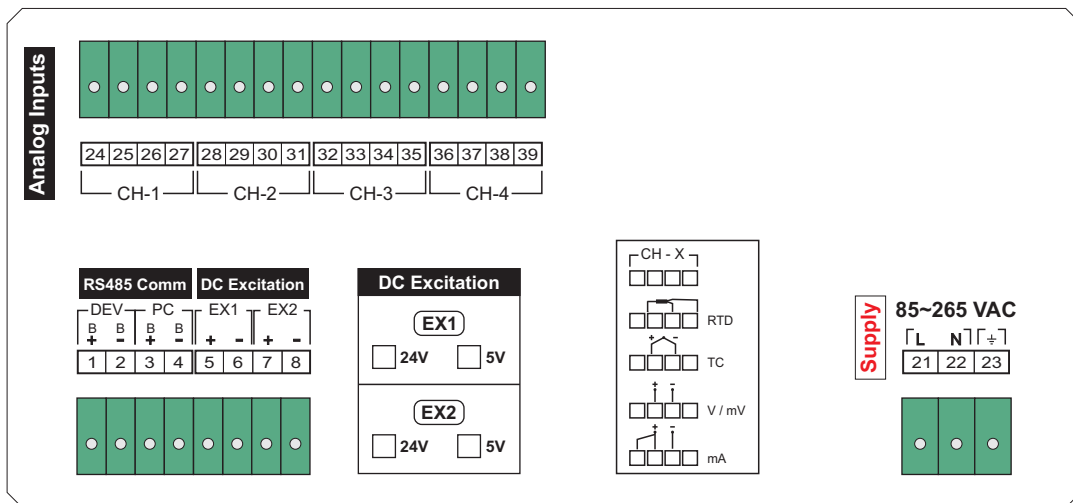

4 Channel With Alarm Relay Outputs

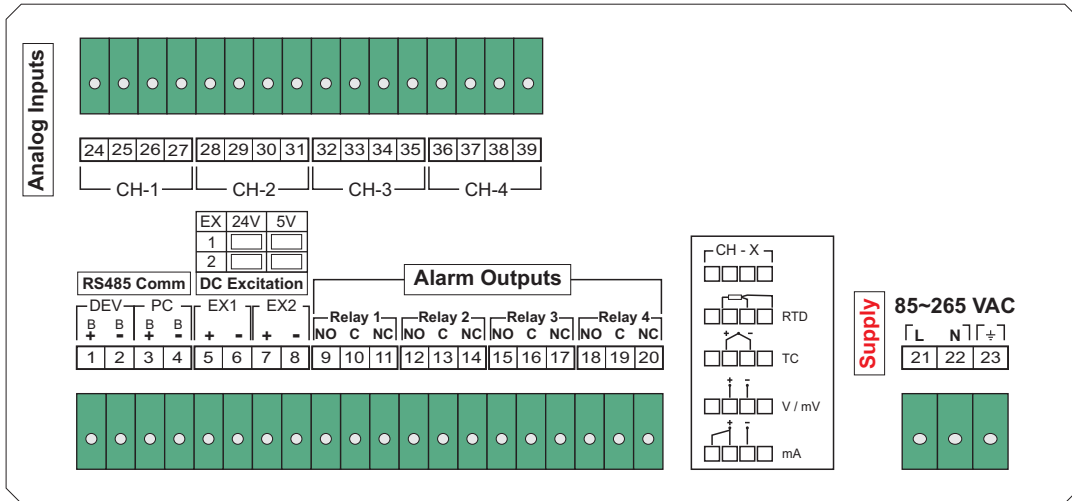

8 Channel Without Alarm Relay Outputs

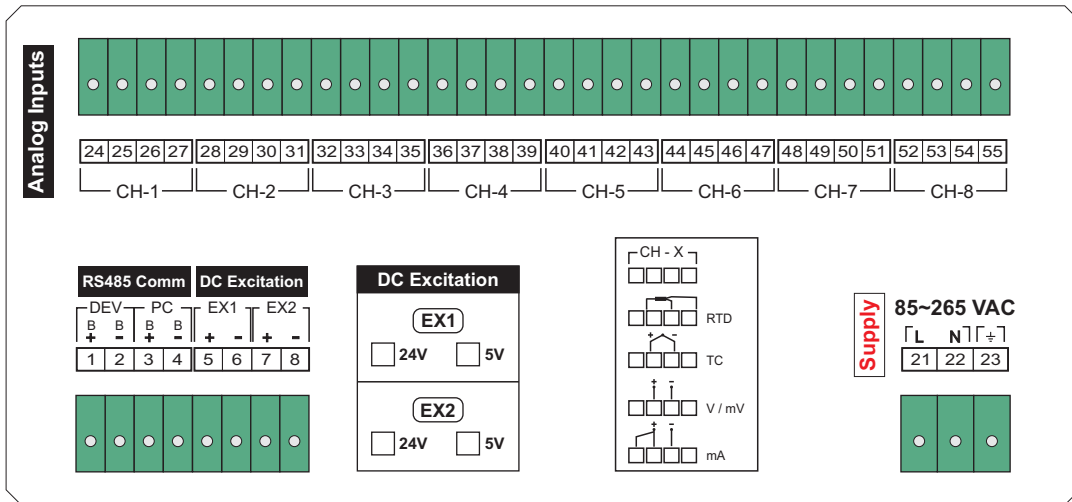

8 Channel With Alarm Relay Outputs

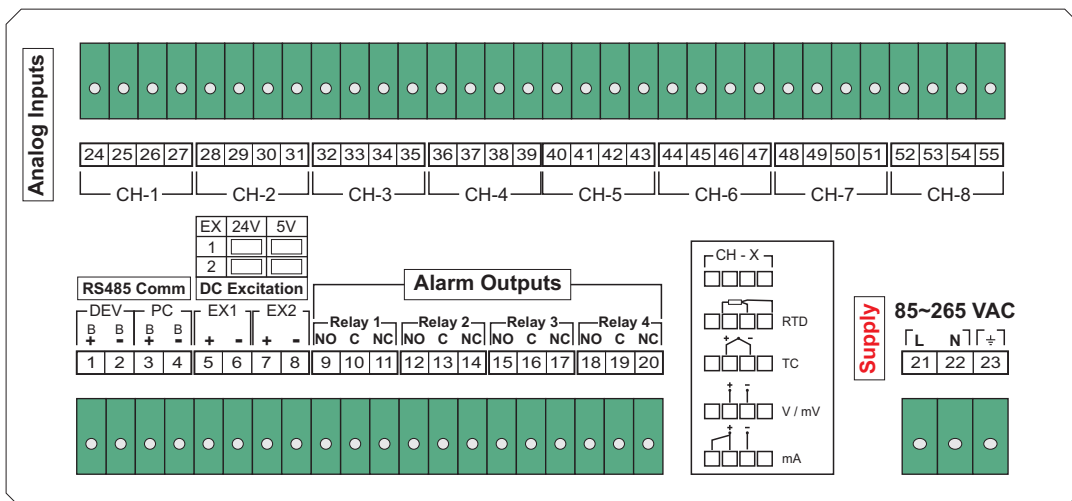

16 Channel With Alarm Relay Outputs

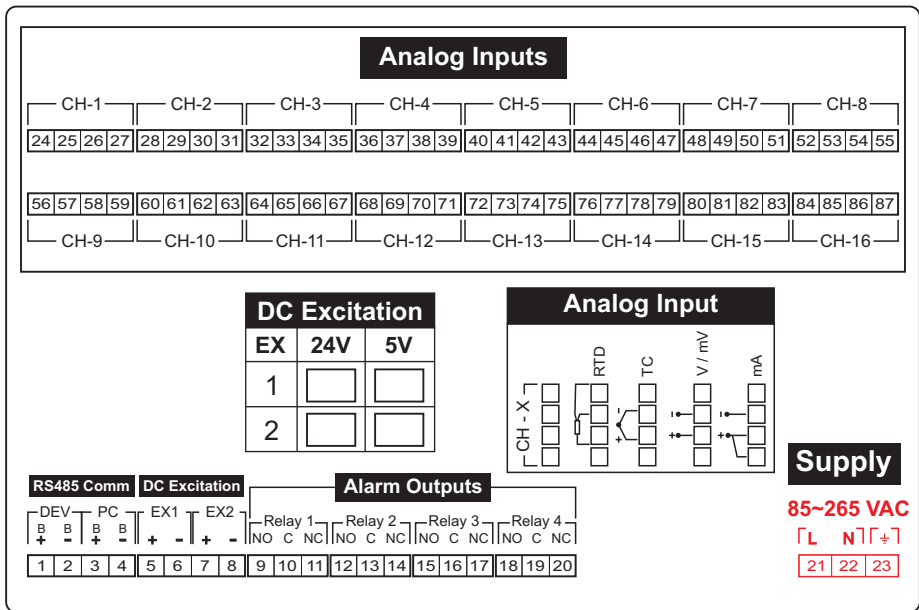

Process Precision Instruments (An ISO 9001 : 2008 Company)

101, Diamond Industrial Estate, Navghar, Vasai Road (E), Dist. Palghar - 401210, Maharashtra, India
 Sales : 8208199048 / 8208141446 Support : 07498799226 / 08767395333
 sales@ppiindia.net www.ppiindia.net

