

HumiTherm Plus



PPI

The Perfection Experts

Micro PLC Based Temperature + Humidity (%RH)
Control & Recording System
with Dot-Matrix Printer Interface

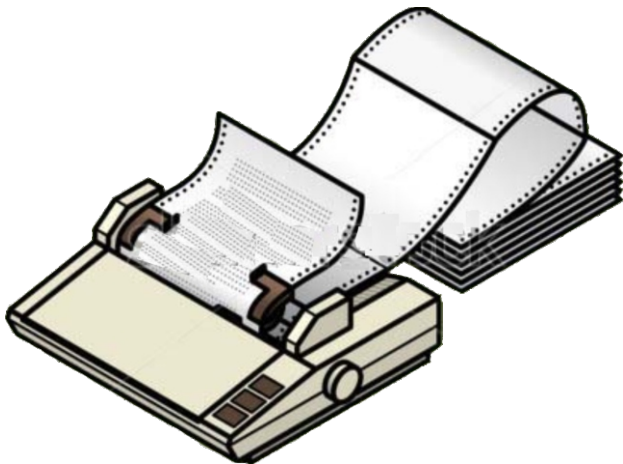

User Manual

CONTENTS

1. FRONT PANEL LAYOUT	1
2. BASIC OPERATION	2
3. OPERATOR PARAMETERS	6
4. SUPERVISORY PARAMETERS	8
5. FACTORY PARAMETER	12
6. PANEL MOUNTING AND ELECTRICAL CONNECTIONS	26
APPENDIX-A : DC LINEAR SIGNAL INTERFACE	30

Section 1 FRONT PANEL LAYOUT

The Controller front panel comprises of Graphic Readout and membrane keys as shown in Figure 1.1 below.

Figure 1.1

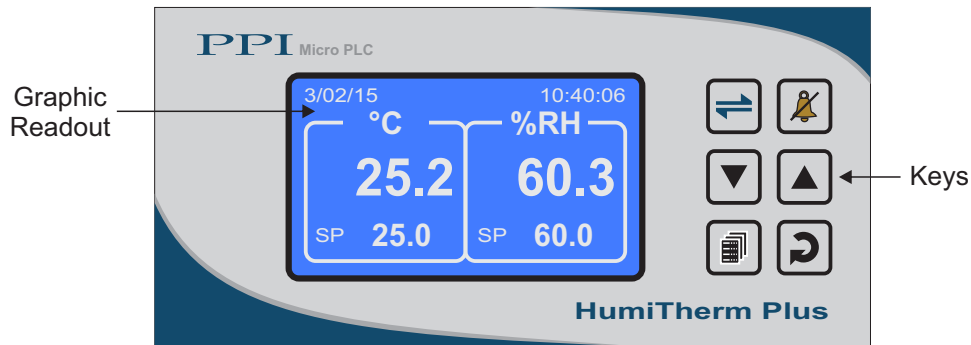

GRAPHIC READOUT

The Graphic Readout is a 160 X 80 Pixel Monochrome LCD Display. In Normal operation mode the Readout shows measured Temperature & Relative Humidity (RH) Values besides Date/Time. Other process information like Alarm Status, Control Status & Stored Records can be viewed using screen scroll feature.

In Set-up Mode, the Readout displays parameter names and values that can be edited using front keys.

KEYS

There are six tactile keys provided on the front panel for configuring the controller and setting-up the parameter values. The Table 1.1 below lists each key (identified by the front panel symbol) and the associated function.

Table 1.1

Symbol	Key	Function
	Scroll	Press to scroll through various Process Information Screens in Normal Operation Mode.
	Alarm Acknowledge	Press to acknowledge and mute (if active) alarm output.
	DOWN	Press to decrease the parameter value. Pressing once decreases the value by one count; keeping pressed speeds up the change.
	UP	Press to increase the parameter value. Pressing once increases the value by one count; keeping pressed speeds up the change.
	SET-UP	Press to enter or exit set-up mode.
	ENTER	Press to store the set parameter value and to scroll to the next parameter.

Section 2 BASIC OPERATIONS

POWER-UP DISPLAY

Figure 2.1 (a)

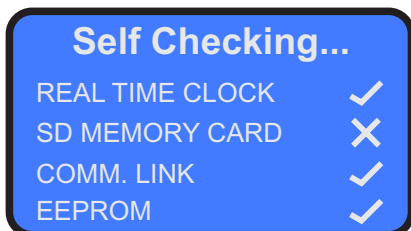
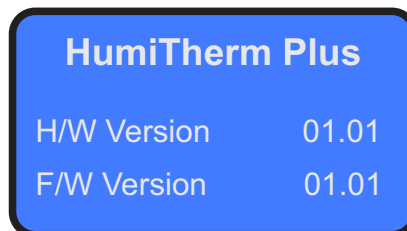

Figure 2.1 (b)



Upon power-up the controller display shows screen depicted in Figure 2.1(a) for 2 Seconds. The controller runs through a self-test sequence for checking its Real Time Clock, SD Memory Card, internal Communication Link and Parameter Storage Memory (EEPROM). The ✓ and ✗ symbols indicate whether a check is passed or failed, respectively. In case any one or more checks fail, the controller starts executing its normal operation but ‘Self Checking’ screen is halted until front panel “Acknowledge” key is pressed. This is followed by screen depicted in Figure 2.1(b) for next 2 Seconds. This screen shows the controller model name, Hardware Version and Firmware Version.

RUN MODE

After the Power-up display sequence the controller enters into RUN Mode. This is the normal operation mode wherein the controller starts PV measurements, Alarm monitoring and Control Loop execution. The Display comprises of several screens described below. The screens appear one-after-the-other upon pressing (Scroll) Key while in RUN Mode.

Main Screen

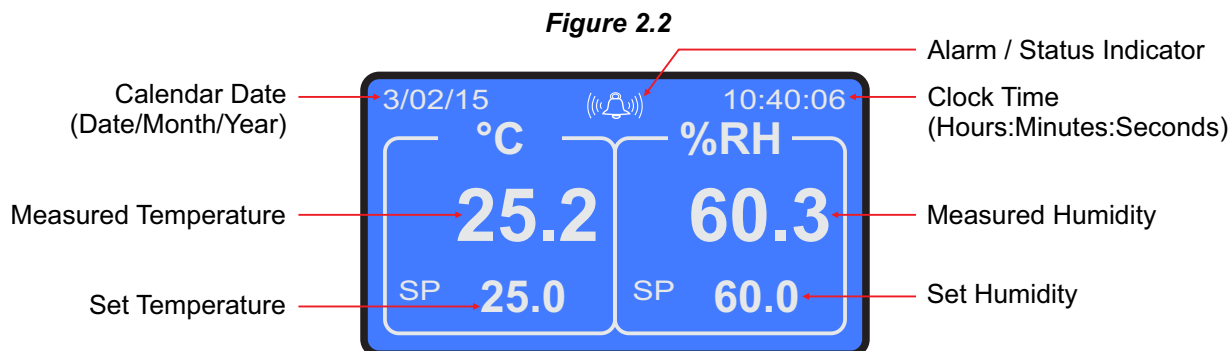

This is the default Run Mode screen that shows Measured Temperature & Humidity Values, Set Temperature & Humidity Values, Calendar Date, Clock Time and Alarm / Status as illustrated in Figure 2.2 above.

In case of measured value errors for Temperature, the messages listed in Table 2.1 flash in place of process value as illustrated in Figure 2.3.

Table 2.1

Message	Error Type	Cause
OPEN	Sensor Open	Sensor (RTD Pt100) Broken / Open
OVR	Over-range	Temperature above Max. Specified Range
UNR	Under-range	Temperature below Min. Specified Range

Figure 2.3

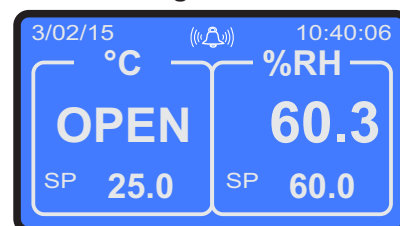

In case of measured value errors for %RH (Sensor disconnected or output value below or above specified range), the measured values are restricted to 0% or 100% depending on signal values.





The 'Alarm / Status' space on the screen may show one of the 3 icons listed in Table 2.2 depending upon the existence of condition. In case of co-existence of multiple conditions, the symbol is indicated based on the associated *Indication Priority*. For Example if the controller is operating on Standby Power Source and enters in to Alarm condition, the  symbol is indicated since it has higher priority over  symbol.

Table 2.2

Symbol	Indication Priority	Condition
	Highest	The Controller is Self Tuning.
	Normal	The Controller is operating on Standby Power Source like battery or inverter.
	Lowest	One or more Alarms are Active.

Process Status Screen

Figure 2.4

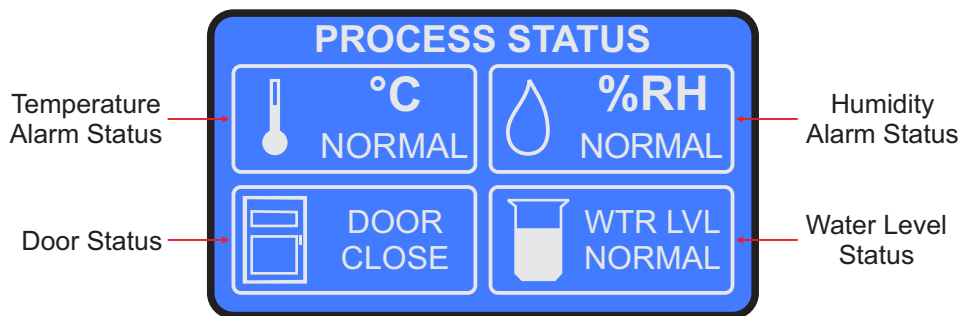

Figure 2.5 (a)

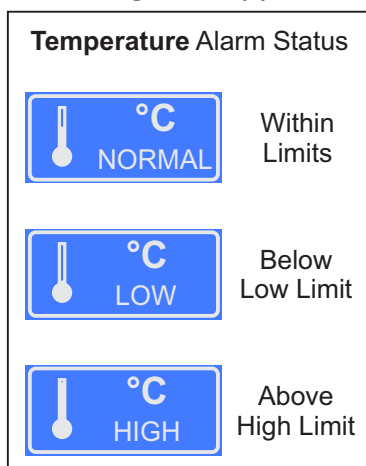

Figure 2.5 (b)

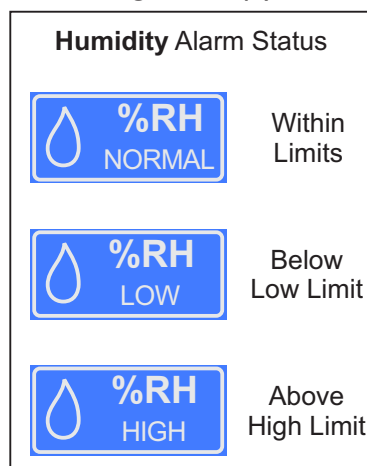

Figure 2.5 (c)

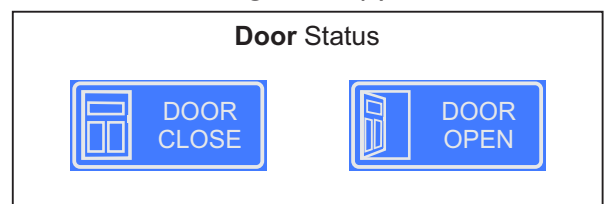
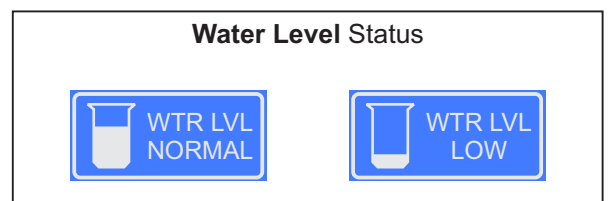



Figure 2.5 (d)



The Process Status Screen is shown upon pressing  (Scroll) key from Main Screen or upon acknowledging a new Alarm by pressing  (Acknowledge) key. As depicted in Figure 2.4; the screen shows Temperature Alarm Status, Humidity Alarm Status, Door Open / Close Status and Water Level Status.

Temperature Alarm Status

The Controller provides programmable Low & High deviation limits around the temperature control setpoint to monitor Alarm conditions. The screen shows either NORMAL or LOW or HIGH Status, as shown in Figure 2.5 (a) depending upon the deviation of measured temperature value from the control setpoint and set limits.

Humidity Alarm Status

The Controller provides programmable Low & High deviation limits around the Humidity control setpoint to monitor Alarm conditions. The screen shows either NORMAL or LOW or HIGH Status, as shown in Figure 2.5 (b) depending upon the deviation of measured %RH value from the control setpoint and set limits.

Door Status

The Controller provides a Digital Input for interfacing Door switch that senses the door position, Open or Close. The screen indicates the door status as shown in Figure 2.5 (c).

Water Level Status

The Controller provides a Digital Input for interfacing Float switch that monitors Water for a minimum (Low) Level in steam generating boiler (humidifier). The screen indicates the water level status as shown in Figure 2.5 (d).

Output Status Screen

Figure 2.6

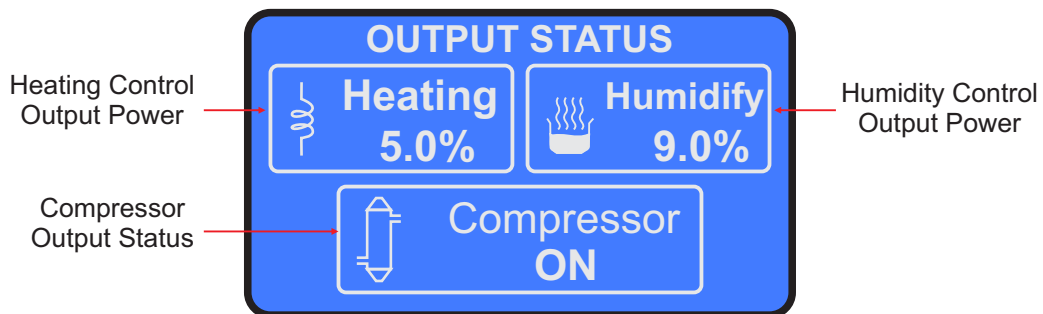



The Output Status Screen is shown upon pressing  (Scroll) key from Process Status Screen. As depicted in Figure 2.6 above; the screen shows the current value for Air Heater Output (Heating) in %, Steam Boiler Output (Humidify) in % & Compressor ON / OFF Status.

Record View Screen

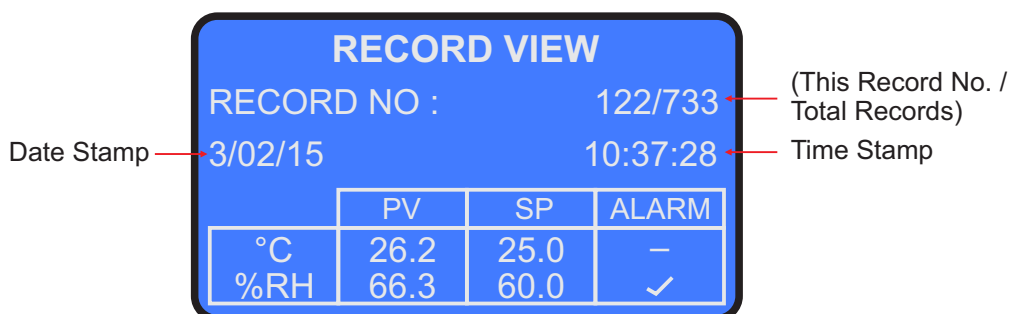
Figure 2.7



The Record View Screen is shown upon pressing  (Scroll) key from Output Status Screen. This screen facilitates viewing of up to most recent 1000 stored records. The records can be scrolled for viewing using  (UP) &  (DOWN) keys. As depicted in Figure 2.7; the record view screen comprises Date & Time stamps, Process Values, Set Values & Alarm Status for Temperature & Humidity. The records are shown sequentially. The Record Number format shows both, the sequential number for the selected record & the total numbers of records available for viewing (for example; 122/733 means the sequential record number is 122 & the total available records are 733).



Section 3 OPERATOR PARAMETERS

The Operator Parameters are accessible under PASSWORD 0. The list includes Parameters for adjusting Control setpoints, Alarm setpoints & Zero-offset for Temperature & %RH.

The Figure 3.1 shows how to access Operator Parameters. The Example illustrates changing the setpoint value for %RH from 60.0 to 70.0.

Figure 3.1

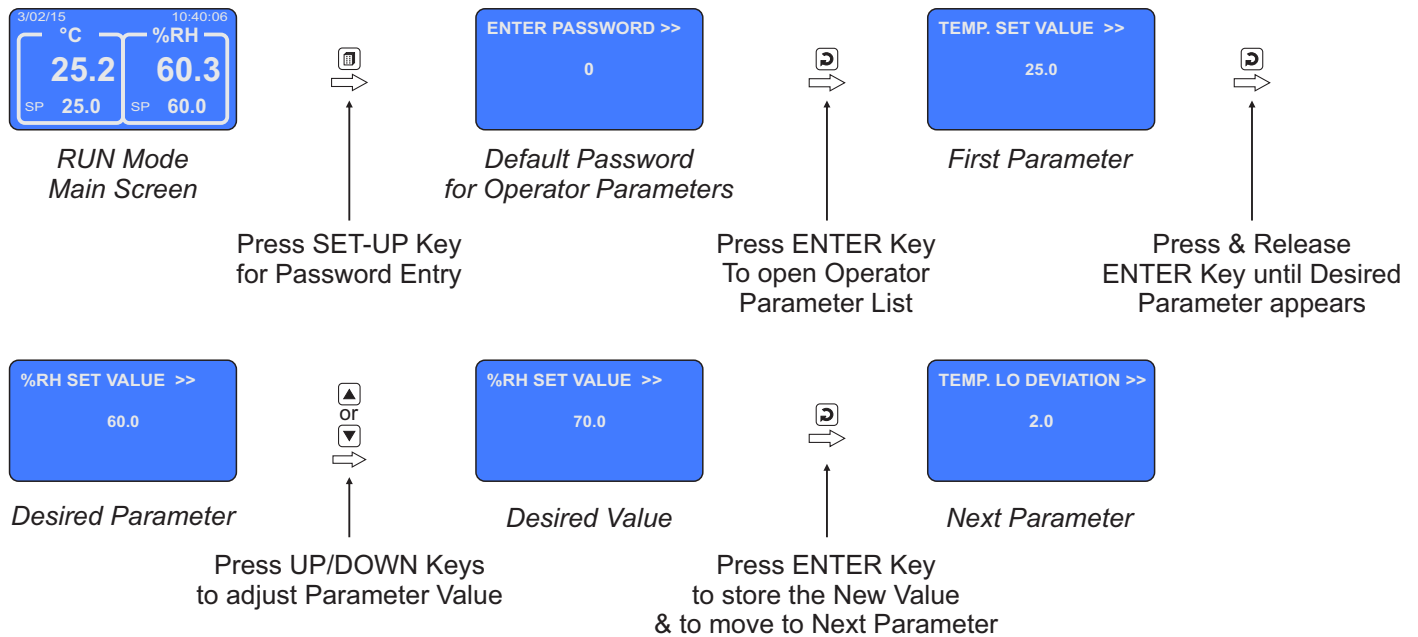

The Table 3.1 below described the Operator Parameters in detail.

Table 3.1

Parameter Description	Settings (Default Value)
<p>SELECT PRNT OPTION>> (This command is available only if Printer Function is enabled and Printer is powered and connected)</p> <p><i>None</i> Skip Printing.</p> <p><i>Print (New)</i> Prints all the available records since previous 'Print (New)' command.</p> <p><i>Re-Print (Old)</i> Re-Prints the records that were printed upon issuing previous 'Print (New)' command.</p> <p><i>Print Info Page</i> Prints a single page information showing the details of abbreviations used to indicate different Events (like Door Open, Power Fail, etc.)</p>	<p>None Print (New) Re-Print (Old) Print Info Page (Default : None)</p>

Parameter Description	Settings (Default Value)
<p>TEMP. SET VALUE >> Set Value for Temperature Control.</p>	<p>SP Low Limit to SP High Limit (Default : 25.0)</p>
<p>%RH SET VALUE >> Set Value for %RH Control.</p>	<p>SP Low Limit to SP High Limit (Default : 60.0)</p>
<p>TEMP. LO DEVIATION >> This Parameter sets a negative deviation (offset) limit with respect to the '<i>Control Set-point</i>' for Temperature. The Alarm is activated if the measured temperature value falls below this limit.</p>	<p>0.2 to 99.9 (Default : 2.0)</p>
<p>TEMP. HI DEVIATION >> This Parameter sets a negative deviation (offset) limit with respect to the '<i>Control Set-point</i>' for Temperature. The Alarm is activated if the measured temperature value exceeds this limit.</p>	<p>0.2 to 99.9 (Default : 2.0)</p>
<p>%RH LO DEVIATION >> This Parameter sets a negative deviation (offset) limit with respect to the '<i>Control Set-point</i>' for %RH. The Alarm is activated if the measured %RH value falls below this limit.</p>	<p>0.2 to 99.9 (Default : 2.0)</p>
<p>%RH HI DEVIATION >> This Parameter sets a negative deviation (offset) limit with respect to the '<i>Control Set-point</i>' for %RH. The Alarm is activated if the measured %RH value exceeds this limit.</p>	<p>0.2 to 99.9 (Default : 2.0)</p>
<p>CHANGE PASSWORD >> The Controller is shipped from the factory with a default password (0) for accessing the parameters reserved for Operator. However, if required the password can be changed by setting the new value for this parameter. (The new password replaces the old password. That is, the old password is no longer valid. it is user's responsibility to memorize the password.)</p>	<p>1 to 100 (Default : 0)</p>



Section 4 SUPERVISORY PARAMETERS

The various parameters have been assembled in various group under the default factory password 123.

Refer Table 4.1 below for a quick summary of parameters under different groups. Each parameter has been described in subsequent sections.

Table 4.1

Group	Parameters
Sensor Input	Temperature Zero Offset, %RH Zero Offset
Recording	Recording Interval, Alarm Toggle, Delete Print Records, Temperature Zero Offset, %RH Zero Offset RTC Time, RTC Date, RTC Month, RTC year
Printer Setting	Line Per Page, Top Margin, Bottom Margin, Header & Footer, Enable
Print Event	Alarm Toggle, RTC Modify, Interval Modify, Power-up, Door Open, Mains Fail, Setpoint Modify
Password	Change Password
Exit	Exit Set-up Mode Yes/No

Accessing Group & Parameters

The Figure 4.1 below illustrates how to access the group and parameters. The example shows changing the value for the parameter 'Top Margin' that is located under group 'Printer Setting'.

Figure 4.1

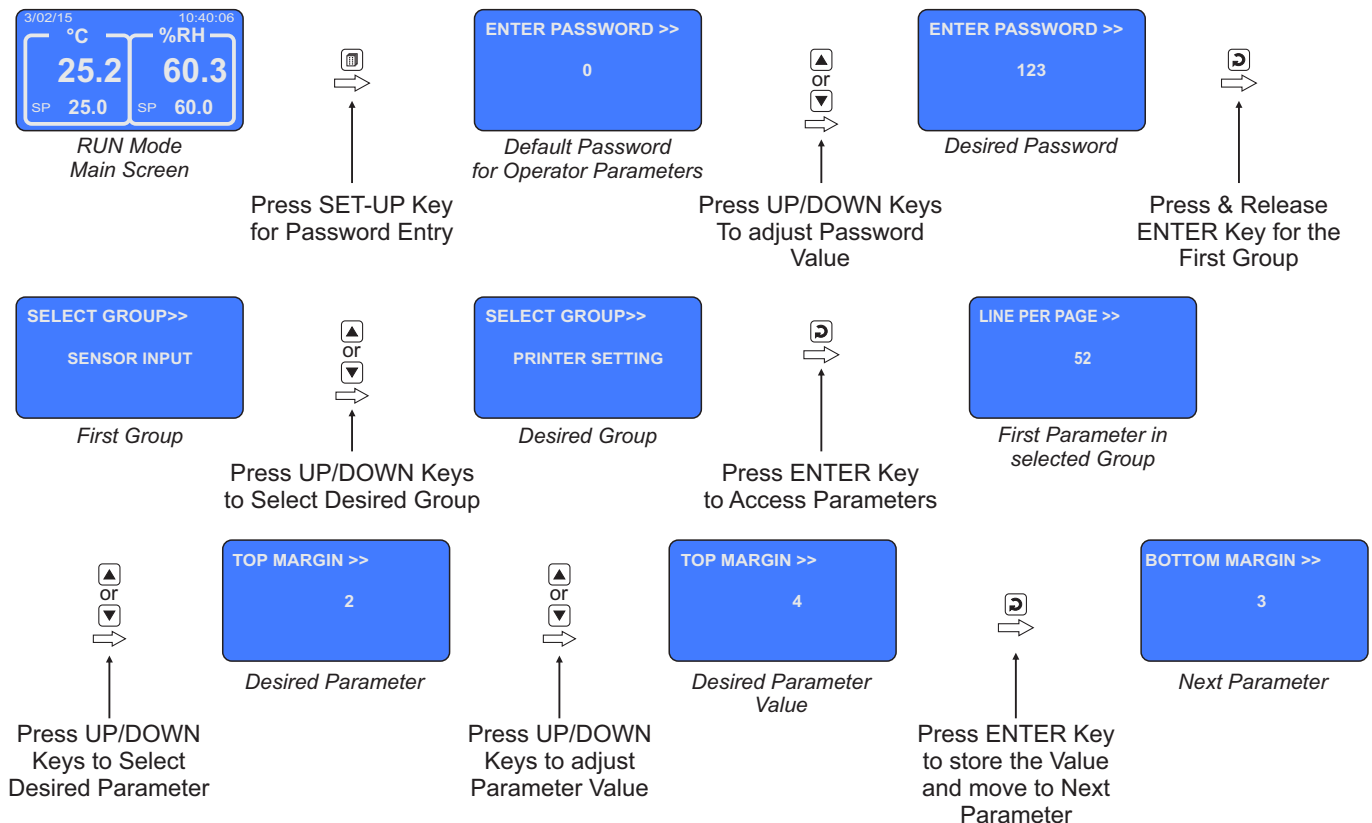

Notes

1. The Last Parameter in the selected Group rolls back to the 'SELECT GROUP' screen again to avoid re-entering the password in case multiple parameters need to be set under the selected Group.
2. Select group 'EXIT' & set parameter 'EXIT SET-UP MODE' to 'YES' for returning to Main Display Mode. Alternately use Set-up Key for instant revert to Main Display Mode.

Parameter Descriptions

The various Supervisory Parameters have been described with their respective group & sub-group.

SUPERVISORY > SENSOR INPUT

Parameter Description	Settings (Default Value)
<p>TEMP. ZERO OFFSET >></p> <p>This value is algebraically added to the measured Temperature Value to derive the final Value that is displayed and compared for alarm / control. Use this value to nullify any known constant error.</p> <p>Final Value = Measured Value + Offset</p>	-50.0 to 50.0 (Default : 0.0)
<p>%RH ZERO OFFSET >></p> <p>This value is algebraically added to the measured RH Value to derive the final Value that is displayed and compared for alarm / control. Use this value to nullify any known constant error.</p> <p>Final Value = Measured Value + Offset</p>	-50.0 to 50.0 (Default : 0.0)

SUPERVISORY > RECORDING

Parameter Description	Settings (Default Value)
<p>REC. INTERVAL (MIN) >></p> <p>The Controller generates and stores periodic records at the interval set by this parameter. The time units are in Minutes.</p> <p>Setting this parameter value to 0 disables normal recording.</p>	0 to 250 Min (Default : 5 Min)
<p>ALRM TOGGLE RECORD >></p> <p>If this parameter is set to 'Enable', the Controller generates and stores a record each time either the temperature or %RH alarm toggles the status (On-to-Off or Off-to-On).</p>	ENABLE DISABLE (Default : ENABLE)
<p>DEL PRINT RECORDS >></p> <p>This parameter is a command that allows the user to delete all the records from the controller memory that are meant for hard copy printout. Set the parameter to "YES" to carry out delete operation.</p>	YES NO (Default : NO)

Parameter Description	Settings (Default Value)
RTC TIME >> Set current clock time in Hrs:Min (24 Hours format).	0 to 23 for Hour 0 to 59 for Min (Default : NA)
RTC DATE >> Set current calendar date.	1 to 31 (Default : NA)
RTC MONTH >> Set current calendar month.	1 to 12 (Default : NA)
RTC YEAR >> Set current calendar year.	2000 to 2099 (Default : NA)

SUPERVISORY > PRINTER SETTING

Parameter Description	Settings (Default Value)
LINE PER PAGE >> This parameter sets the page length in terms of total print lines including the top and bottom margins.	25 to 100 (Default : 65)
TOP MARGINE >> This parameter sets the blank space in terms of numbers of lines from the top edge of the print page.	1 to 5 (Default : 2)
BOTTOM MARGINE >> This parameter sets the blank space in terms of numbers of lines above the bottom edge of the print page.	1 to 5 (Default : 2)
HEADER & FOOTER >> <i>No</i> Header / Footer never printed. <i>On First Page</i> Header / Footer is printed on the first page only. <i>Every Page</i> Header / Footer is printed on every page.	No On First Page Every Page (Default : No)
ENABLE >> <i>No</i> Disables Printer function and suppresses all print related commands / parameters. <i>Yes</i> Enables Printer function.	YES NO (Default : NO)

SUPERVISORY > PRINT EVENT

The controller generates instantaneous records of several Events such as Alarm Toggle, Power-up, Door Open, etc. These records are in addition to the records generated at regular user set time interval. The printouts of event generated records are marked with specific abbreviations for differentiation. The user, however, has an option to individually suppress these records for printing by setting the related parameters to “NO”.

The Table lists the parameters associated with the Events that can be selected (set to “Yes”) or suppressed (set to “No”) for printing.

Parameter Description	Settings (Default Value)
ALARM TOGGLE >>	YES NO (Default : YES)
RTC MODIFY >>	
INTERVAL MODIFY >>	
POWER UP >>	
DOOR OPEN >>	
MAINS FAIL >>	
SETPOINT MODIFY >>	

SUPERVISORY > PASSWORD

Parameter Description	Settings (Default Value)
CHANGE PASSWORD >> The Controller is shipped from the factory with a default password (123) for accessing the parameters reserved for the equipment manufacturer. However, if required the password can be changed by setting the new value for this parameter. (The new password replaces the old password. That is, the old password is no longer valid. it is user’s responsibility to memorize the password.)	1000 to 1999 (Default : 123)

SUPERVISORY > EXIT

Parameter Description	Settings (Default Value)
EXIT SETUP MODE >> Select ‘Yes’ to quit <i>Setup</i> mode and return to <i>Main Display</i> mode.	YES NO (Default : NO)



Section 5

FACTORY PARAMETERS

The various parameters have been assembled in groups and sub-groups under the password 321.

Refer Table 5.1 below for a quick summary of parameters under different groups & sub-groups. Each parameter has been described in subsequent sections.

Table 5.1

Group	Sub-Group	Parameters
Temperature Setting	Alarm	Hysteresis, Inhibit
	Control	Tune, Set-point Low Limit, Set-point High Limit, Proportional Band, Integral Time, Derivative Time, Cycle Time
	Sensor Input	Input Type, Signal Low, Signal High, Range Low, Range High
Humidity Setting	Alarm	Hysteresis, Inhibit
	Control	Tune, Set-point Low Limit, Set-point High Limit, Proportional Band, Integral Time, Derivative Time, Cycle Time
	Sensor Input	Input Type, Signal Low, Signal High, Range Low, Range High
Compressor Setting	-----	Time Delay
Boiler Water Level	-----	Enable/Disable, Water Level Strategy, Switch - 1 Logic, Switch - 2 Logic
Door Open	-----	Enable/Disable, Switch Logic, Door Alarm Delay
Mains Failure	-----	Enable/Disable, Switch Logic
Factory Default	-----	Set to Default Yes/No
Exit	-----	Exit Set-up Mode Yes/No

Accessing Group/Sub-group & Parameters

The Figure 5.1 below illustrates how to access the group/sub-group and parameters. The example shows changing the value for the parameter 'Proportional Band' for Humidity Control that is located under group 'Humidity Settings' & sub-group 'Control'.

Figure 5.1

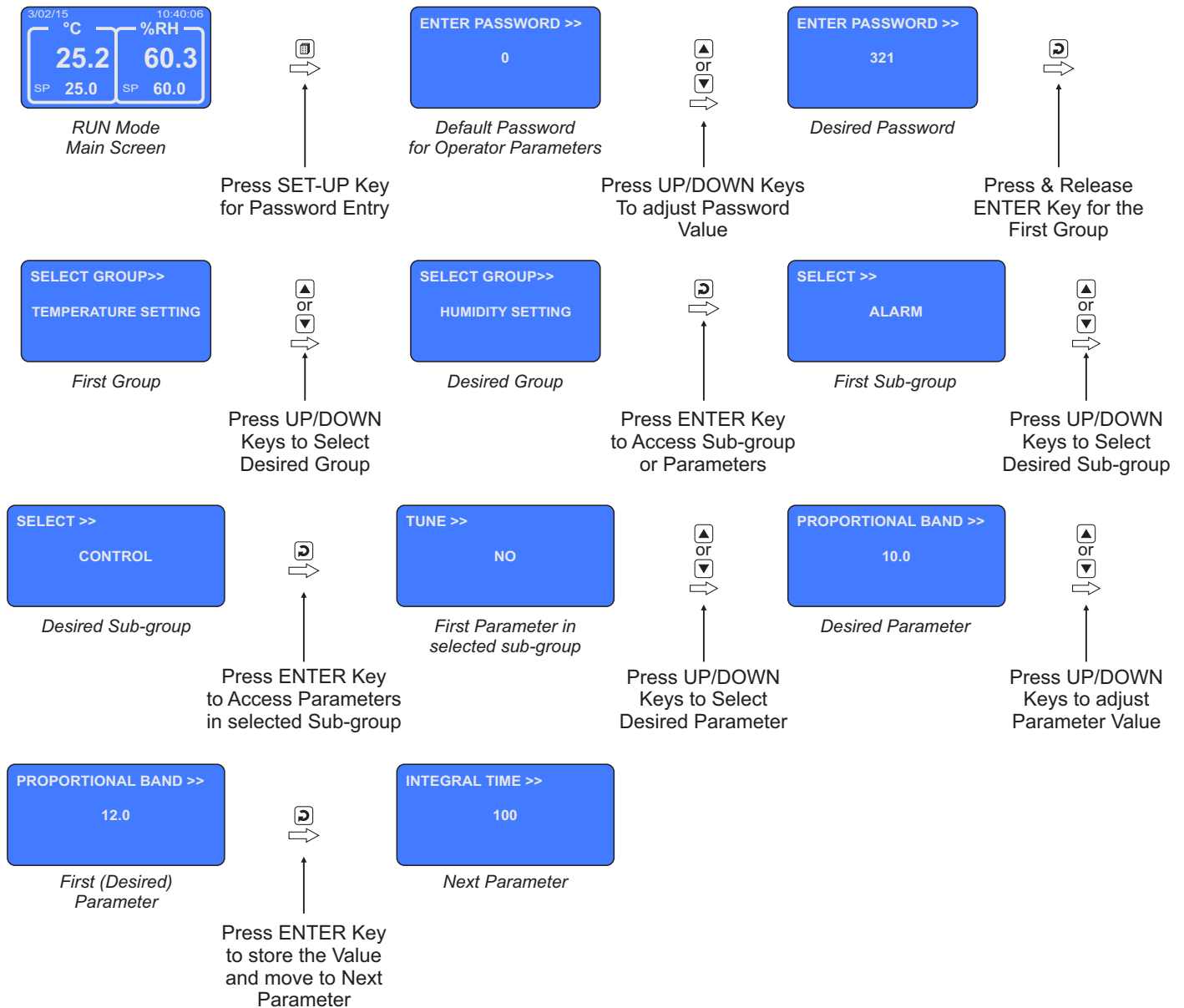

Notes

1. The Last Parameter in the selected Group or Sub-group rolls back to the 'SELECT GROUP' screen again to avoid re-entering the password in case multiple parameters need to be set under different Group or Sub-group.
2. Select group 'EXIT' & set parameter 'EXIT SET-UP MODE' to 'YES' for returning to Main Display Mode. Alternately use Set-up Key for instant revert to Main Display Mode.

For convenience this Temperature Settings group is further divided into 3 sub-groups : Alarm Parameters, Control Parameters & Sensor Input Parameters.

FACTORY > TEMPERATURE > ALARM

Parameter Description	Settings (Default Value)
<p>HYSTERESIS >></p> <p>This parameter sets a differential (dead) band between the ON and OFF Alarm status change. Keep it large enough to avoid frequent switching of the Alarm Status/Relay.</p>	<p>0.1 to 99.9 (Default : 0.2)</p>
<p>INHIBIT >></p> <p><i>Yes</i> The Alarm activation is suppressed until the Temperature value is within Alarm limits from the time the controller is switched ON. This allows suppressing the Alarm during the start-up Alarm conditions.</p> <p><i>No</i> The Alarm is not suppressed during the start-up Alarm conditions.</p>	<p>YES NO (Default : YES)</p>

FACTORY > TEMPERATURE > CONTROL

Parameter Description	Settings (Default Value)
<p>TUNE >></p> <p>Set 'Yes' to activate and 'No' to abort the Tuning operation.</p> <p><i>Note:</i> The tuning is always performed simultaneously on both Temperature & Humidity.</p>	<p>YES NO (Default : NO)</p>
<p>SETPOINT LO LIMIT >></p> <p>Minimum permissible setpoint value for Temperature control.</p>	<p>-99.9 to SETPOINT HI LIMIT (Default : 10.0)</p>
<p>SETPOINT HI LIMIT >></p> <p>Maximum permissible setpoint value for Temperature control.</p>	<p>For RTD : SETPOINT LO LIMIT to 600.0 For mA/V : SETPOINT LO LIMIT to 999.9 (Default : 60.0)</p>

Parameter Description	Settings (Default Value)
Control Zones : Dual	
CZ PROP BAND >> Sets proportional gain for Cool Pre-dominant zone.	0.1 to 999.9 (Default : 50.0)
CZ INTEGRAL TIME >> Sets integral time constant in Seconds for Cool Pre-dominant zone. Setting the value to 0, cuts-off integral action.	0 to 3600 Sec (Default : 100 Sec)
CZ DERIVATIVE TIME >> Sets derivative time constant in Seconds for Cool Pre-dominant zone. Setting the value to 0, cuts-off derivative action.	0 to 600 Sec (Default : 16 Sec)
HZ PROP BAND >> Sets proportional gain for Heat Pre-dominant zone.	0.1 to 999.9 (Default : 50.0)
HZ INTEGRAL TIME >> Sets integral time constant in Seconds for Heat Pre-dominant zone. Setting the value to 0, cuts-off integral action.	0 to 3600 Sec (Default : 100 Sec)
HZ DERIVATIVE TIME >> Sets derivative time constant in Seconds for Heat Pre-dominant zone. Setting the value to 0, cuts-off derivative action.	0 to 600 Sec (Default : 16 Sec)
CYCLE TIME >> Sets the total 'On + Off' time in seconds for time proportional power output through Relay / SSR.	0.5 to 100.0 Sec (Default : 10.0 Sec)
Control Zones : Single	
PROPORTIONAL BAND >> Sets proportional gain (% output power per unit error).	0.1 to 999.9 (Default : 50.0)
INTEGRAL TIME >> Sets integral time constant in Seconds. Setting the value to 0, cuts-off integral action.	0 to 3600 Sec (Default : 100 Sec)
DERIVATIVE TIME >> Sets derivative time constant in seconds. Setting the value to 0, cuts-off derivative action.	0 to 600 Sec (Default : 16 Sec)
CYCLE TIME >> Sets the total 'On + Off' time in seconds for time proportional power output through Relay / SSR.	0.5 to 100.0 Sec (Default : 10.0 Sec)

FACTORY > TEMPERATURE > SENSOR INPUT

Parameter Description	Settings (Default Value)																		
<p>INPUT TYPE >> Select Input type in accordance with the type of Temperature sensor / transmitter connected for measurement.</p>	<p>RTD Pt100 0-20mA 4-20mA 0-5V 0-10V 1-5V (Default : RTD Pt100)</p>																		
<p>SIGNAL LO >> <i>(Available for DC linear V & mA Inputs only)</i> The transmitter output signal value corresponding to Range Low process value. Refer <i>Appendix-A : DC Linear Signal Interface</i> for details.</p>	<table border="1"> <thead> <tr> <th>Input Type</th> <th>Settings</th> <th>Default</th> </tr> </thead> <tbody> <tr> <td>0 to 20 mA</td> <td>0.00 to Signal High</td> <td>0.00</td> </tr> <tr> <td>4 to 20 mA</td> <td>4.00 to Signal High</td> <td>4.00</td> </tr> <tr> <td>0 to 5 V</td> <td>0.000 to Signal High</td> <td>0.000</td> </tr> <tr> <td>0 to 10 V</td> <td>0.00 to Signal High</td> <td>0.00</td> </tr> <tr> <td>1 to 5 V</td> <td>1.000 to Signal High</td> <td>1.000</td> </tr> </tbody> </table>	Input Type	Settings	Default	0 to 20 mA	0.00 to Signal High	0.00	4 to 20 mA	4.00 to Signal High	4.00	0 to 5 V	0.000 to Signal High	0.000	0 to 10 V	0.00 to Signal High	0.00	1 to 5 V	1.000 to Signal High	1.000
Input Type	Settings	Default																	
0 to 20 mA	0.00 to Signal High	0.00																	
4 to 20 mA	4.00 to Signal High	4.00																	
0 to 5 V	0.000 to Signal High	0.000																	
0 to 10 V	0.00 to Signal High	0.00																	
1 to 5 V	1.000 to Signal High	1.000																	
<p>SIGNAL HI >> <i>(Available for DC linear V & mA Inputs only)</i> The transmitter output signal value corresponding to Range High process value. Refer <i>Appendix-A : DC Linear Signal Interface</i> for details.</p>	<table border="1"> <thead> <tr> <th>Input Type</th> <th>Settings</th> <th>Default</th> </tr> </thead> <tbody> <tr> <td>0 to 20 mA</td> <td>Signal Low to 20.00</td> <td>20.00</td> </tr> <tr> <td>4 to 20 mA</td> <td>Signal Low to 20.00</td> <td>20.00</td> </tr> <tr> <td>0 to 5 V</td> <td>Signal Low to 5.000</td> <td>5.000</td> </tr> <tr> <td>0 to 10 V</td> <td>Signal Low to 10.00</td> <td>10.00</td> </tr> <tr> <td>1 to 5 V</td> <td>Signal Low to 5.000</td> <td>5.000</td> </tr> </tbody> </table>	Input Type	Settings	Default	0 to 20 mA	Signal Low to 20.00	20.00	4 to 20 mA	Signal Low to 20.00	20.00	0 to 5 V	Signal Low to 5.000	5.000	0 to 10 V	Signal Low to 10.00	10.00	1 to 5 V	Signal Low to 5.000	5.000
Input Type	Settings	Default																	
0 to 20 mA	Signal Low to 20.00	20.00																	
4 to 20 mA	Signal Low to 20.00	20.00																	
0 to 5 V	Signal Low to 5.000	5.000																	
0 to 10 V	Signal Low to 10.00	10.00																	
1 to 5 V	Signal Low to 5.000	5.000																	
<p>RANGE LO >> <i>(Available for DC linear V & mA Inputs only)</i> The process value corresponding to the Signal Low value from the transmitter. Refer <i>Appendix-A : DC Linear Signal Interface</i> for details.</p>	<p>-199.9 to RANGE HI (Default : 0.0)</p>																		
<p>RANGE HI >> <i>(Available for DC linear V & mA Inputs only)</i> The process value corresponding to the Signal High value from the transmitter. Refer <i>Appendix-A : DC Linear Signal Interface</i> for details.</p>	<p>RANGE LO to 999.9 (Default : 100.0)</p>																		

For convenience this Humidity (%RH) Settings group is further divided into 3 sub-groups : Alarm Parameters, Control Parameters & Sensor Input Parameters.

FACTORY > HUMIDITY (%RH) > ALARM

Parameter Description	Settings (Default Value)
HYSTERESIS >> This parameter sets a differential (dead) band between the ON and OFF Alarm status change. Keep it large enough to avoid frequent switching of the Alarm Status/Relay.	0.1 to 99.9 (Default : 0.2)
INHIBIT >> <i>Yes</i> The Alarm activation is suppressed until the %RH value is within Alarm limits from the time the controller is switched ON. This allows suppressing the Alarm during the start-up Alarm conditions. <i>No</i> The Alarm is not suppressed during the start-up Alarm conditions.	YES NO (Default : YES)

FACTORY > HUMIDITY (%RH) > CONTROL

Parameter Description	Settings (Default Value)
TUNE >> Set 'Yes' to activate and 'No' to abort the Tuning operation. <i>Note:</i> The tuning is always performed simultaneously on both Temperature & Humidity.	YES NO (Default : NO)
SETPOINT LO LIMIT >> Minimum permissible setpoint value for %RH control.	-99.9 to SETPOINT HI LIMIT (Default : 10.0)
SETPOINT HI LIMIT >> Maximum permissible setpoint value for %RH control.	For RTD : SETPOINT LO LIMIT to 600.0 For mA/V : SETPOINT LO LIMIT to 999.9 (Default : 60.0)

Parameter Description	Settings (Default Value)
Control Zones : Dual	
CZ PROP BAND >> Sets proportional gain for Cool Pre-dominant zone.	0.1 to 999.9 (Default : 50.0)
CZ INTEGRAL TIME >> Sets integral time constant in Seconds for Cool Pre-dominant zone. Setting the value to 0, cuts-off integral action.	0 to 3600 Sec (Default : 100 Sec)
CZ DERIVATIVE TIME >> Sets derivative time constant in Seconds for Cool Pre-dominant zone. Setting the value to 0, cuts-off derivative action.	0 to 600 Sec (Default : 16 Sec)
HZ PROP BAND >> Sets proportional gain for Heat Pre-dominant zone.	0.1 to 999.9 (Default : 50.0)
HZ INTEGRAL TIME >> Sets integral time constant in Seconds for Heat Pre-dominant zone. Setting the value to 0, cuts-off integral action.	0 to 3600 Sec (Default : 100 Sec)
HZ DERIVATIVE TIME >> Sets derivative time constant in Seconds for Heat Pre-dominant zone. Setting the value to 0, cuts-off derivative action.	0 to 600 Sec (Default : 16 Sec)
CYCLE TIME >> Sets the total 'On + Off' time in seconds for time proportional power output through Relay / SSR.	0.5 to 100.0 Sec (Default : 10.0 Sec)
Control Zones : Single	
PROPORTIONAL BAND >> Sets proportional gain (% output power per unit error).	0.1 to 999.9 (Default : 50.0)
INTEGRAL TIME >> Sets integral time constant in Seconds. Setting the value to 0, cuts-off integral action.	0 to 3600 Sec (Default : 100 Sec)
DERIVATIVE TIME >> Sets derivative time constant in seconds. Setting the value to 0, cuts-off derivative action.	0 to 600 Sec (Default : 16 Sec)
CYCLE TIME >> Sets the total 'On + Off' time in seconds for time proportional power output through Relay / SSR.	0.5 to 100.0 Sec (Default : 10.0 Sec)

FACTORY > HUMIDITY (%RH) > SENSOR INPUT

Parameter Description	Settings (Default Value)																		
<p>INPUT TYPE >> Select Input type in accordance with the type of %RH sensor / transmitter connected for measurement.</p>	<p>0-20mA 4-20mA 0-5V 0-10V 1-5V (Default : 0-5V)</p>																		
<p>SIGNAL LO >> <i>(Available for DC linear V & mA Inputs only)</i> The transmitter output signal value corresponding to Range Low process value. Refer <i>Appendix-A : DC Linear Signal Interface</i> for details.</p>	<table border="1" style="width: 100%; border-collapse: collapse;"> <thead> <tr> <th style="text-align: left;">Input Type</th> <th style="text-align: left;">Settings</th> <th style="text-align: left;">Default</th> </tr> </thead> <tbody> <tr> <td>0 to 20 mA</td> <td>0.00 to Signal High</td> <td>0.00</td> </tr> <tr> <td>4 to 20 mA</td> <td>4.00 to Signal High</td> <td>4.00</td> </tr> <tr> <td>0 to 5 V</td> <td>0.000 to Signal High</td> <td>0.000</td> </tr> <tr> <td>0 to 10 V</td> <td>0.00 to Signal High</td> <td>0.00</td> </tr> <tr> <td>1 to 5 V</td> <td>1.000 to Signal High</td> <td>1.000</td> </tr> </tbody> </table>	Input Type	Settings	Default	0 to 20 mA	0.00 to Signal High	0.00	4 to 20 mA	4.00 to Signal High	4.00	0 to 5 V	0.000 to Signal High	0.000	0 to 10 V	0.00 to Signal High	0.00	1 to 5 V	1.000 to Signal High	1.000
Input Type	Settings	Default																	
0 to 20 mA	0.00 to Signal High	0.00																	
4 to 20 mA	4.00 to Signal High	4.00																	
0 to 5 V	0.000 to Signal High	0.000																	
0 to 10 V	0.00 to Signal High	0.00																	
1 to 5 V	1.000 to Signal High	1.000																	
<p>SIGNAL HI >> <i>(Available for DC linear V & mA Inputs only)</i> The transmitter output signal value corresponding to Range High process value. Refer <i>Appendix-A : DC Linear Signal Interface</i> for details.</p>	<table border="1" style="width: 100%; border-collapse: collapse;"> <thead> <tr> <th style="text-align: left;">Input Type</th> <th style="text-align: left;">Settings</th> <th style="text-align: left;">Default</th> </tr> </thead> <tbody> <tr> <td>0 to 20 mA</td> <td>Signal Low to 20.00</td> <td>20.00</td> </tr> <tr> <td>4 to 20 mA</td> <td>Signal Low to 20.00</td> <td>20.00</td> </tr> <tr> <td>0 to 5 V</td> <td>Signal Low to 5.000</td> <td>5.000</td> </tr> <tr> <td>0 to 10 V</td> <td>Signal Low to 10.00</td> <td>10.00</td> </tr> <tr> <td>1 to 5 V</td> <td>Signal Low to 5.000</td> <td>5.000</td> </tr> </tbody> </table>	Input Type	Settings	Default	0 to 20 mA	Signal Low to 20.00	20.00	4 to 20 mA	Signal Low to 20.00	20.00	0 to 5 V	Signal Low to 5.000	5.000	0 to 10 V	Signal Low to 10.00	10.00	1 to 5 V	Signal Low to 5.000	5.000
Input Type	Settings	Default																	
0 to 20 mA	Signal Low to 20.00	20.00																	
4 to 20 mA	Signal Low to 20.00	20.00																	
0 to 5 V	Signal Low to 5.000	5.000																	
0 to 10 V	Signal Low to 10.00	10.00																	
1 to 5 V	Signal Low to 5.000	5.000																	
<p>RANGE LO >> <i>(Available for DC linear V & mA Inputs only)</i> The process value corresponding to the Signal Low value from the transmitter. Refer <i>Appendix-A : DC Linear Signal Interface</i> for details.</p>	<p>-199.9 to RANGE HI (Default : 0.0)</p>																		
<p>RANGE HI >> <i>(Available for DC linear V & mA Inputs only)</i> The process value corresponding to the Signal High value from the transmitter. Refer <i>Appendix-A : DC Linear Signal Interface</i> for details.</p>	<p>RANGE LO to 999.9 (Default : 100.0)</p>																		

FACTORY > COMPRESSOR

Compressor Switching Strategies

The PPI “Temperature + Humidity” composite controllers offer different programmable strategies for compressor switching to meet different design approaches by the manufacturers of Humidity Chambers. The various strategies and the implementations are described here.

1. Compressor Off

The compressor is kept Off. This strategy is usually selected for temperature values significantly above the ambient temperature.

2. Compressor On

The compressor is kept On regardless of the measured or set temperature value. This strategy is usually selected for temperature values significantly below the ambient temperature.

3. SP Based Strategy

In this strategy, the chamber temperature range is split in two zones by setting the parameter 'Boundary Set-point' (BSP). Refer Figure 5.2 below.

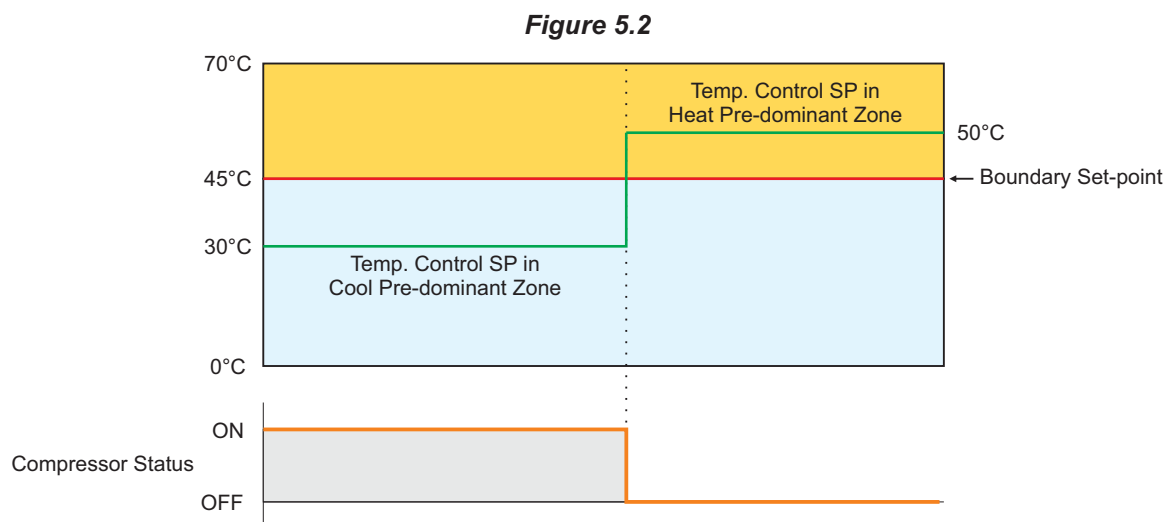

The zone at and above the boundary SP () is referred as Heat Pre-dominant zone and that below the boundary SP () is referred as Cool Pre-dominant zone. The controller automatically switches between the two zones depending upon the Temperature SP. If the Temperature SP is below boundary SP, Cool Pre-dominant zone is active and the compressor is kept ON. If the Temperature SP is at or above boundary SP, Heat Pre-dominant zone is active and the compressor is kept OFF. This strategy eliminates the need for the user to manually switch the compressor ON or OFF.

If the parameter *Control Zones* is set to “Dual”; separate tuning can be performed in the Cool and Heat Pre-dominant zones for accurate control in each zone. The controller maintains separate sets of Proportional Band, Integral Time & Derivative Time constants for each zone that are automatically selected and used by the controller depending upon the active zone.

However, if the parameter *Control Zones* is set to “Single”; the controller uses a single set of Proportional Band, Integral Time & Derivative Time constants for both zones.

4. PV Based Strategy

In this strategy, the compressor is switched to cool down the chamber air temperature. The controller switches the compressor ON or OFF based on the comparison between the chamber temperature value and the Temperature SP. Refer Figure 5.3 below.

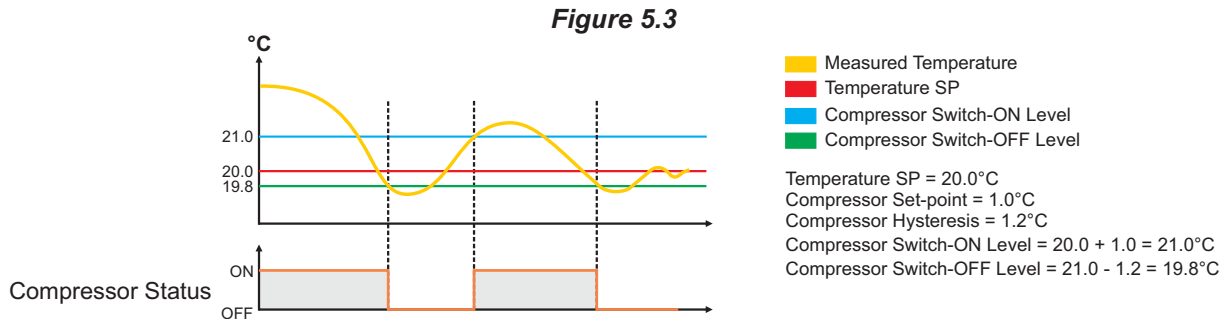

The compressor is turned ON if the chamber air temperature value is above the Temperature SP by an amount set by the parameter 'Compressor Set-point'. That is;

$$\text{Compressor Switch - ON Level} = (\text{Temperature SP}) + (\text{Compressor Set-point})$$

Once the air temperature falls below Compressor Switch-ON Level by an amount set by the parameter 'Compressor Hysteresis', the compressor is turned OFF. That is;

$$\text{Compressor Switch - OFF Level} = (\text{Compressor Switch-ON Level}) - (\text{Compressor Hysteresis})$$

The hysteresis inserts a dead band between the Compressor Switch-ON Level and Compressor Switch-OFF Level to avoid frequent switching of the compressor.

Compressor Time Delay

Once the compressor is switched off, a time delay is desired before it is turned ON again. The time delay prevents the possible damage due to short cycling. When the compressor switches off, it spins backward as pressure equalizes. If compressor is energized while it is still spinning backward, it continues to run backward until it trips on internal overloads. This may cause damage to the compressor.

The time delay cycle is executed every time the compressor is turned off. The compressor turning off may be a result of power failure or the on-off control algorithm executed by the controller. The controller in "Auto Mode" monitors the Process Value (PV) against the Set-Point (SP) and attempts to switch the compressor ON or OFF depending upon whether the PV is above or below the SP.

The time delay starts counting down from the instance the compressor is switched off. The compressor is inhibited from switching-on until the delay elapses regardless of the difference between the PV and SP. Once the time delay is elapsed, the control algorithm switches the compressor ON as and when the PV is above SP.

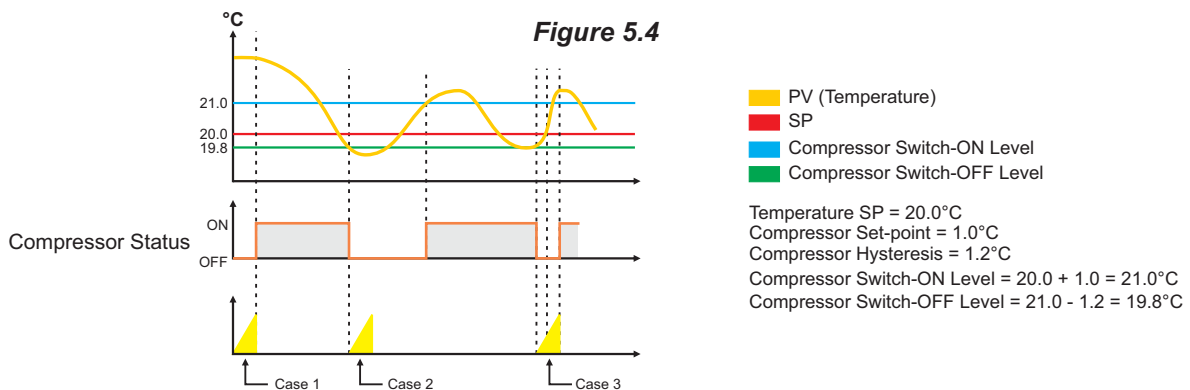

The figure 5.4 above illustrates 3 cases. Case (1) illustrates power-up delay. In case (2); the time elapses before PV rises above the SP. The compressor is thus switched ON as soon as the PV rises above the SP. In case (3); the PV rises above the SP while the time delay is still in progress. The compressor is switched ON as soon as the delay time elapses.

Table 5.2 lists various parameters required for setting-up appropriate compressor switching strategy and associated parameters.

For parameter description the user is requested to read the preceding section.

Table 5.2

Control Strategy : Heat + Cool		
COMPRESSOR STRATEGY >>		CONT. OFF CONT. ON SP BASED PV BASED (Default : CONT. ON)
CONT. ON	SP BASED	PV BASED
TIME DELAY (SEC) >> 0 to 1000 Sec (Default : 200 Sec)	BOUNDARY SET VALUE >> 0.0 to 100.0 (Default : 45.0)	COMPRESSOR SP >> 0.0 to 100.0 (Default : 45.0)
	CONTROL ZONES >> SINGLE DUAL (Default : SINGLE)	HYSTERESIS >> 0.1 to 99.9 (Default : 2.0)
	TIME DELAY (SEC) >> 0 to 1000 Sec (Default : 200 Sec)	TIME DELAY (SEC) >> 0 to 1000 Sec (Default : 200 Sec)

FACTORY > BOILER WATER LEVEL

Parameter Description	Settings (Default Value)
<p>ENABLE >> Set to 'Yes' if water level Sensor(s) is mounted for detecting Low water level.</p>	<p>YES NO (Default : NO)</p>
<p>WATER LEVEL STRATEGY >> <i>Single Switch</i> A single float type sensor is installed for detecting low water level. <i>Dual Switch Low / High</i> A Sensor with two switches for detecting both Low & High levels is installed. <i>Dual Switch Low / Very Low</i> A Sensor with two switches for detecting two different water levels as Low & Very Low is installed.</p>	<p>SINGLE SWITCH DUAL SWITCH LO-HI DUAL SWITCH LO-VLO (Default : SINGLE SWITCH)</p>
<p>SWITCH-1 LOGIC >> <i>Close : Water Level Low</i> The water level is considered <i>Low</i> if the switch is CLOSE. <i>Open : Water level Low</i> The water level is considered <i>Low</i> if the switch is OPEN.</p>	<p>CLOSE : WATER LO OPEN : WATER LO (Default : CLOSE : WATER LO)</p>
<p>SWITCH-2 LOGIC >> (Available only if water Level Sensor with Dual Switches is installed) Case-1 : Water Level Strategy is 'Dual Switch Low / High' <i>Close : Water Level High</i> The water level is considered <i>High</i> if the switch is CLOSE. <i>Open : Water Level High</i> The water level is considered <i>High</i> if the switch is OPEN. Case-2 : Water Level Strategy is 'Dual Switch Low / Very Low' <i>Close : Water Level Very Low</i> The water level is considered <i>Very Low</i> if the switch is CLOSE. <i>Open : Water Level Very Low</i> The water level is considered <i>Very Low</i> if the switch is OPEN.</p>	<p>CLOSE : WATER HI OPEN : WATER HI (Default : CLOSE : WATER HI) OR CLOSE : WATER VLO OPEN : WATER VLO (Default : CLOSE : WATER VLO)</p>

FACTORY > DOOR OPEN

Parameter Description	Settings (Default Value)
<p>ENABLE >></p> <p>Set to 'Yes' if Switch is mounted for detecting door <i>Open / Close</i> position.</p>	<p>YES NO (Default : NO)</p>
<p>SWITCH LOGIC >></p> <p><i>Close : Door Open</i> The Door position is considered <i>Open</i> if the switch is CLOSE.</p> <p><i>Open : Door Open</i> The Door position is considered <i>Open</i> if the switch is OPEN.</p>	<p>CLOSE : DOOR OPEN OPEN : DOOR OPEN (Default : CLOSE : DOOR OPEN)</p>
<p>DOOR ALRM DLY (SEC) >></p> <p>This parameter sets a timer. From the time the door is opened, the timer begins counting down. If the door is not closed before the timer reaches 0, the <i>Door Open</i> alarm is activated.</p>	<p>0 to 1000 Sec (Default : 60 Sec)</p>

FACTORY > MAINS FAILURE

Parameter Description	Settings (Default Value)
<p>ENABLE >></p> <p>Set to 'Yes' if provision is made for running the controller on an auxiliary power sources like battery or inverter and a Switch is mounted for detecting main power source failure.</p>	<p>YES NO (Default : NO)</p>
<p>SWITCH LOGIC >></p> <p><i>Close : Mains Fail</i> The CLOSE Switch position indicates that the Mains Power has failed and the Controller is operating on auxiliary power source.</p> <p><i>Open : Mains Fail</i> The OPEN Switch position indicates that the Mains Power has failed and the Controller is operating on auxiliary power source.</p>	<p>CLOSE : MAINS FAIL OPEN : MAINS FAIL (Default : CLOSE : MAINS FAIL)</p>

FACTORY > FACTORY DEFAULT

Parameter Description	Settings (Default Value)
SET TO DEFAULT >> Set to 'Yes' to set all the parameter values to their Default Values.	YES NO (Default : NO)

FACTORY > PASSWORD

Parameter Description	Settings (Default Value)
CHANGE PASSWORD >> The Controller is shipped from the factory with a default password (321) for accessing the parameters reserved for the equipment manufacturer. However, if required the password can be changed by setting the new value for this parameter. (The new password replaces the old password. That is, the old password is no longer valid. it is user's responsibility to memorize the password.)	2000 to 2999 (Default : 321)

FACTORY > EXIT

Parameter Description	Settings (Default Value)
EXIT SETUP MODE >> Select 'Yes' to quit <i>Setup</i> mode and return to <i>Main Display</i> mode.	YES NO (Default : NO)

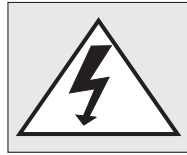

Section 6

PANEL MOUNTING AND ELECTRICAL CONNECTIONS

WARNING
MISHANDLING / NEGLIGENCE
CAN RESULT IN PERSONAL DEATH
OR SERIOUS INJURY.

PANEL CUTOUT

Figure 6.1

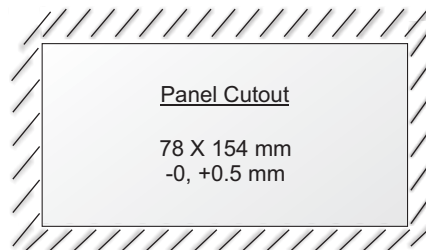
**PANEL MOUNTING**

Follow the steps below for mounting the instrument on panel :

1. Prepare a cutout to the size shown in Figure 6.1.
2. Remove the Panel Mounting Clamp from the instrument Enclosure.
3. Insert the rear of the enclosure through the panel cutout from the front of the mounting panel.
4. Fix the mounting clamp pair such that it ensures secured mounting of the enclosure against the panel wall.

ELECTRICAL CONNECTIONS

1. The user must rigidly observe the Local Electrical Regulations.
2. Do not make any connections to the unused terminals for making a tie-point for other wires (or for any other reasons) as they may have some internal connections. Failing to observe this may result in permanent damage to the controller.
3. Run power supply cables separated from the low-level signal cables (like **RTD, DC** Linear Current/Voltage, etc.). If the cables are run through conduits, use separate conduits for power supply cable and low-level signal cables.
4. Use appropriate fuses and switches, wherever necessary, for driving the high voltage loads to protect the controller from any possible damage due to high voltage surges of extended duration or short-circuits on loads.
5. Take care not to over-tighten the terminal screws while making connections.
6. Make sure that the controller supply is switched-off while making/removing any connections or removing the controller from its enclosure.

CONNECTION DIAGRAM

The Electrical Connection Diagram is shown on the back side of the controller enclosure. The diagram shows the terminals viewed from the **REAR SIDE** with the controller label upright. The Connection Diagram is a generic one; the connections shown for optional modules are applicable only if the modules are fitted.

Figure 6.2

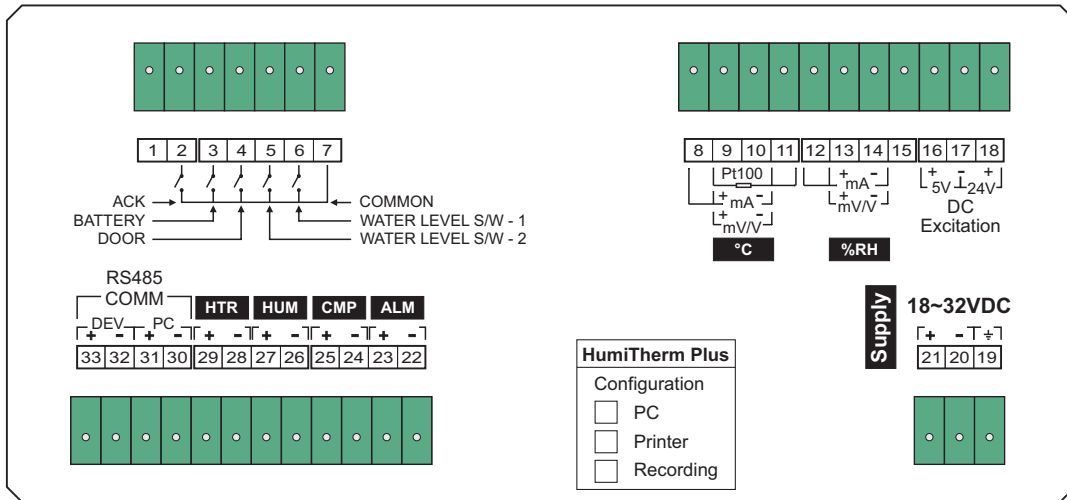

DESCRIPTIONS

The back panel connections are described as under:

Temperature (°C) Sensor / Transmitter Input (Terminals : 8, 9, 10, 11)

The Controller accepts RTD Pt100 (3-wire / 2-wire) or DC Current (mA) / DC Voltage (V) as Temperature input. The connections are described.

Figure 6.3 (a)

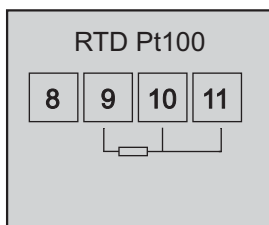

RTD Pt100, 3-wire

Connect single lead end of RTD bulb to terminal 9 and the double lead ends to terminals 10 & 11 as shown in Figure 6.3 (a). Use copper conductor leads of very low resistance ensuring that all 3 leads are of the same gauge and length. Avoid joints in the cable.

Temperature Transmitter with DC Voltage (V) Output

The Figure 6.3 (b) depicts wiring connections for voltage output transmitter. The Excitation Voltage can be obtained from an external source or from the controller.

Temperature Transmitter with DC Current (mA) Output

The Figure 6.3 (c) depicts wiring connections for current output transmitter. Note that terminals 8 & 9 should be shorted. The Excitation Voltage can be obtained from an external source or from the controller.

Figure 6.3 (b)

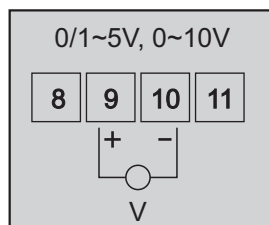
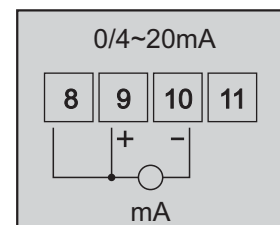

Figure 6.3 (c)



Humidity (%RH) Transmitter Input (Terminals : 12,13, 14)

The Controller accepts DC Current (mA) / DC Voltage (V) as Humidity input. The connections are described below.

Humidity Transmitter with DC Voltage (V) Output

The Figures 6.4(a) depicts wiring connections for voltage output transmitter. The Excitation Voltage can be obtained from an external source or from the controller.

Figure 6.4 (a)

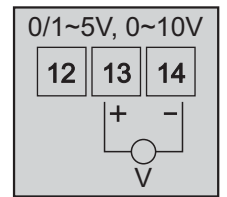

Humidity Transmitter with DC Current (mA) Output

The Figures 6.4(b) depict wiring connections for current output transmitter. Note that terminals 12 & 13 should be shorted. The Excitation Voltage can be obtained from an external source or from the controller.

Figure 6.4 (b)

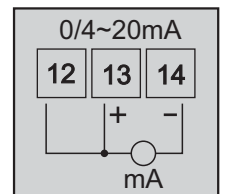

5 VDC / 24 VDC Excitation Voltage (Terminals : 16, 17, 18)

The Controller is supplied with inbuilt 5VDC Excitation Voltage as standard. In addition, 24VDC Excitation Voltage can be supplied on request. The Excitation Voltage can be used to power external Temperature and/or RH Transmitters.

The '+' and '-' terminals are for voltage 'Source' and 'Return' paths, respectively.

Heater Control Output (terminals : 28, 29)

Humidity Control Output (terminals : 26, 27)

Compressor Control Output (terminals : 24, 25)

Alarm Output (terminals : 22, 23)

All the above control & alarm outputs are Voltage pulses (12VDC @ 40mA) for driving external SSR or Relay. The '+' and '-' terminals are for voltage 'Source' and 'Return' paths, respectively.

Water Level Switch-1 Digital Input (Terminals 6, 7)

Water Level Switch-2 Digital Input (Terminals 5, 7)

Door Detect Digital Input (Terminals 4, 7)

Battery Detect Digital Input (Terminals 3, 7)

Alarm Acknowledge Digital Input (Terminals 2, 7)

Potential-free contact closure input terminals are provided as digital inputs. An 'Open' or 'Close' switch position is detected as input.

PC COMMUNICATION PORT (Terminals 30, 31)

Figure 6.5

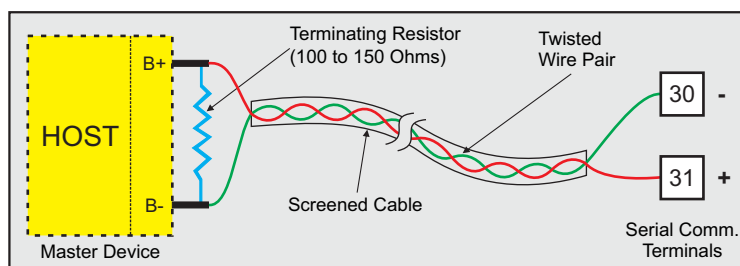

The controller Communication Port is RS485 and requires a similar port at the host (master) end. If, however, the host port is different (say, RS232), use appropriate protocol converter (say, RS485-RS232) for interface.

For reliable noise free communication, use a pair of twisted wires inside screened cable as shown in Figure 6.5. The wire should have less than 100 ohms / km nominal DC resistance (Typically 24 AWG or thicker). Connect the terminating resistor (Typically 100 to 150 ohm) at one end to improve noise immunity.

PRINTER / GSM INTERFACE COMMUNICATION PORT (Terminals 32, 33)

If the controller supports Dot Matrix Printer or GSM module interface, used RS485 Communication Port available on terminals 32 & 33.

POWER SUPPLY (Terminals 20, 21)

Figure 6.6

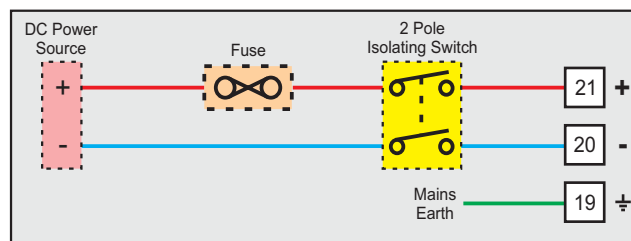

As standard, the Module is supplied with power connections suited for 18 to 32 VDC power source. The accuracy / performance of the Module is not affected by the variations in the supply within specified limits of 18 to 32 VDC. Use well-insulated copper conductor wire of the size not smaller than 0.5mm² for power supply connections ensuring proper polarity as shown in Figure 6.6. The Module is not provided with fuse and power switch. If necessary, mount them separately. Use a slow blow fuse rated for 0.5A current.

For safety and enhanced electrical noise immunity, it is highly recommended to connect Main Power Supply 'Earth' to terminal 19.



APPENDIX - A

DC LINEAR SIGNAL INTERFACE

This appendix describes the parameters required to interface process transmitters that produce Linear DC Voltage (mV/V) or Current (mA) signals in proportion to the measured process values. A few examples of such transmitters are;

1. Pressure Transmitter producing **4 to 20 mA** for **0 to 5 psi**
2. Relative Humidity Transmitter producing **1 to 4.5 V** for **5 to 95 %RH**
3. Temperature Transmitter producing **0 to 20 mA** for **-50 to 250 °C**

The instrument (indicator/controller/recorder) that accepts the linear signal from the transmitter computes the measured process value by solving the mathematical equation for Straight-Line in the form:

$$Y = mX + C$$

Where;

- X : Signal Value from Transmitter
- Y : Process Value Corresponding to Signal Value X
- C : Process Value Corresponding to X = 0 (Y-intercept)
- m : Change in Process Value per unit Change in Signal Value (Slope)

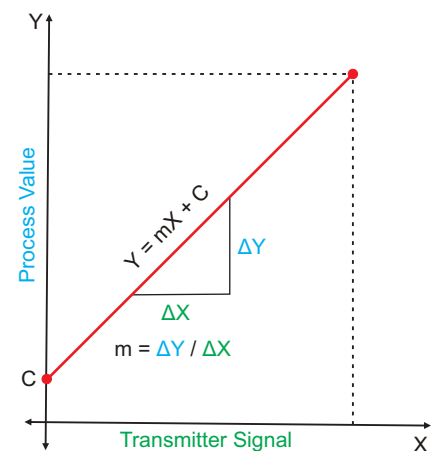

As is evident from the aforementioned transmitter examples, different transmitters produce signals varying both in *Type* (mV/V/mA) and *Range*. Most PPI instruments, thus, provide programmable Signal Type and Range to facilitate interface with a variety of transmitters. A few industry standard signal types and ranges offered by the PPI instruments are: 0-50mV, 0-200mV, 0-5 V, 1-5 V, 0-10V, 0-20 mA, 4-20 mA, etc.

Also, the output signal range (e.g. 1 to 4.5 V) from different transmitters corresponds to different process value range (e.g. 5 to 95 %RH); the instruments thus also provide facility for programming the measured process value range with programmable Resolution.

The linear transmitters usually specify two signal values (Signal Low and Signal High) and the corresponding Process Values (Range Low and Range High). In the example Pressure Transmitter above; the Signal Low, Signal High, Range Low & Range High values specified are: 4 mA, 20 mA, 0 psi & 5 psi, respectively.

In summary, the following 6 parameters are required for interfacing Linear Transmitters:

1. Input Type : Standard DC Signal Type in which the transmitter signal range fits (e.g. 4-20 mA)
2. Signal Low : Signal value corresponding to Range Low process value (e.g. 4 mA)
3. Signal High : Signal value corresponding to Range High process value (e.g. 20 mA)
4. PV Resolution : Resolution (least count) with which to compute process value (e.g. 0.01)
5. Range Low : Process value corresponding to Signal Low value (e.g. 0.00 psi)
6. Range High : Process value corresponding to Signal High value (e.g. 5.00 psi)

The following examples illustrate appropriate parameter value selections.

Example 1: Pressure Transmitter producing 4 to 20 mA for 0 to 5 psi

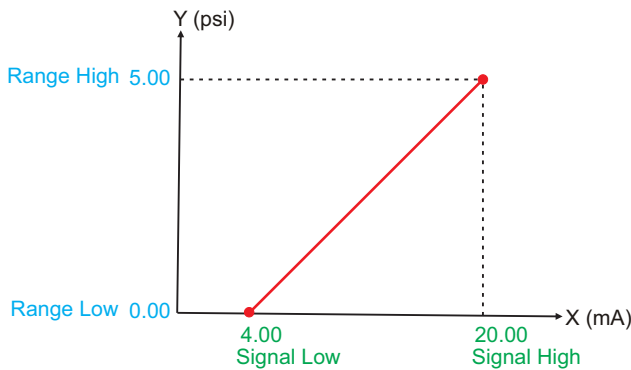

Presume the pressure is to be measured with 0.01 Resolution, that is 0.00 to 5.00 psi.

Input Type : 4-20 mA
 Signal Low : 4.00 mA
 Signal High : 20.00 mA
 PV Resolution : 0.01
 Range Low : 0.00
 Range High : 5.00

Example 2: Relative Humidity Transmitter producing 1 to 4.5 V for 5 to 95 %RH

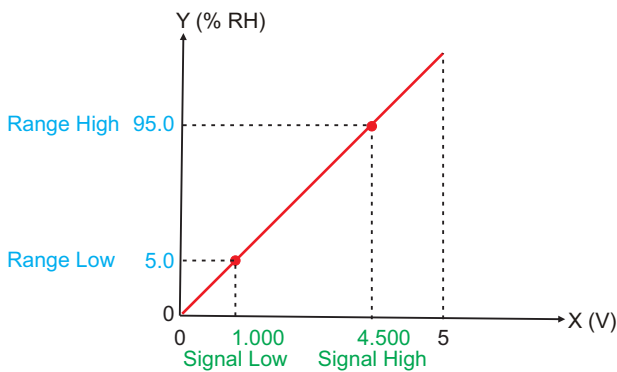

Presume the humidity is to be measured with 0.1 Resolution, that is 0.0 to 100.0 %.

Input Type : 0-5 V
 Signal Low : 1.000 V
 Signal High : 4.500 V
 PV Resolution : 0.1
 Range Low : 5.0
 Range High : 95.0

Example 3: Temperature Transmitter producing 0 to 20 mA for -50 to 250 °C

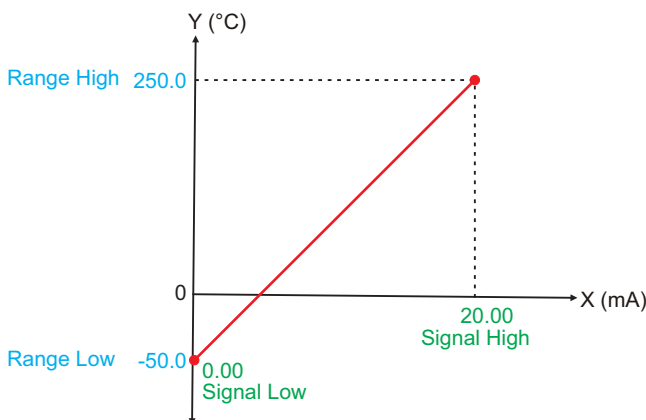

Presume the Temperature is to be measured with 0.1 Resolution, that is -50.0 to 250.0°C.

Input Type : 0-20 mA
 Signal Low : 0.00 mA
 Signal High : 20.00 mA
 PV Resolution : 0.1
 Range Low : -50.0
 Range High : 250.0





PPI
The Perfection Experts

Process Precision Instruments

101, Diamond Industrial Estate, Navghar, Vasai Road (E),
Dist. Palghar - 401 210. Maharashtra, India



Sales : 8208199048 / 8208141446

Support : 07498799226 / 08767395333



sales@ppiindia.net, support@ppiindia.net