

# LabCon (Printer)

## Recording + Printer Interface

# Operation Manual

This brief manual is primarily meant for quick reference to wiring connections and parameter searching. For more details on operation and application; please log on to [www.ppiindia.net](http://www.ppiindia.net)

PPI

101, Diamond Industrial Estate, Navghar,  
Vasai Road (E), Dist. Palghar - 401 210.  
Sales : 8208199048 / 8208141446  
Support : 07498799226 / 08767395333  
E: [sales@ppiindia.net](mailto:sales@ppiindia.net), [support@ppiindia.net](mailto:support@ppiindia.net)

Jan 2022

OPERATOR PAGE PARAMETERS	
Parameters	Settings (Default Value)
Select Print Option >>	None Print (New) Re-Print (Old) Print Info Page (Default : None)
Time Start Command >>	Yes No (Default : No)
Time Abort Command >>	(Default : No)
Time Interval (H:M) >>	0.00 to 500.00 (HH:MM) (Default : 0.10)
Ctrl Set Value >>	Setpoint LO limit to Setpoint HI limit (Resolution 0.1°C for RTD / DC Linear & 1°C for Thermocouple) (Default : 25.0)
Ctrl Lo Deviation >>	For RTD & DC Linear : 0.2 to 99.9 For Thermocouple : 2 to 99 (Default : 2.0)
Ctrl Hi Deviation >>	For RTD & DC Linear : 0.2 to 99.9 For Thermocouple : 2 to 99 (Default : 2.0)
Change Password >>	1 to 100 (Default : 0)

SUPERVISORY > SENSOR INPUT	
Parameters	Settings (Default Value)
Ctrl Zero Offset >>	-50 to 50 (Resolution 0.1°C for RTD / DC Linear & 1°C for Thermocouple) (Default : 0.0)

SUPERVISORY > RECORDING	
Parameters	Settings (Default Value)
Rec. Interval (min) >>	0 to 250 Min (Default : 5 Min)
Alarm Toggle Record >>	Enable Disable (Default : Enable)
Del Print Records >>	Yes No (Default : No)
Del Display Record >>	Yes No (Default : No)
RTC Time >>	0 to 23 for Hour 0 to 59 for Min (Default : NA)
RTC Date >>	1 to 31 (Default : NA)
RTC Month >>	1 to 12 (Default : NA)
RTC Year >>	2000 to 2099 (Default : NA)

SUPERVISORY > CONTROL	
Parameters	Settings (Default Value)
Tune >>	Yes No (Default : No)
Setpoint LO Limit >>	Min Range for the Selected Input Type to Setpoint HI Limit (Resolution 0.1°C for RTD / DC Linear & 1°C for Thermocouple) (Default : 0.0)
Setpoint HI Limit >>	Setpoint LO Limit to Max Range for the Selected Input Type (Resolution 0.1°C for RTD / DC Linear & 1°C for Thermocouple) (Default : 600.0)
Compressor Setpoint >>	0 to 100 (Resolution 0.1°C for RTD / DC Linear & 1°C for Thermocouple) (Default : 45.0)
Compressor Hyst >>	0.1 to 99.9 (Default : 2.0)
Heat Ctrl Action >>	ON-OFF PID (Default : PID)
Heat Hyst >>	0.1 to 99.9 (Default : 0.2)

Heat Only Control	Heat + Cool Control Zone : Single	Heat + Cool Control Zone : Dual
<b>Proportional Band &gt;&gt;</b> 0.1 to 999.9 (Default : 50.0)	<b>Proportional Band &gt;&gt;</b> 0.1 to 999.9 (Default : 50.0)	<b>Cz Prop Band &gt;&gt;</b> Proportional Band for Cool Pre-dominant zone 0.1 to 999.9 (Default : 50.0)
<b>Integral Time &gt;&gt;</b> 0 to 3600 sec (Default : 100 sec)	<b>Integral Time &gt;&gt;</b> 0 to 3600 sec (Default : 100 sec)	<b>Cz Integral Time &gt;&gt;</b> Integral Time for Cool Pre-dominant zone 0 to 3600 sec (Default : 100 sec)
<b>Derivative Time &gt;&gt;</b> 0 to 600 sec (Default : 16 sec)	<b>Derivative Time &gt;&gt;</b> 0 to 600 sec (Default : 16 sec)	<b>Cz Derivative Time &gt;&gt;</b> Derivative Time for Cool Pre-dominant zone 0 to 600 sec (Default : 16 sec)
<b>Cycle Time &gt;&gt;</b> 0.5 to 100.0 sec (Default : 10.0 sec)	<b>Cycle Time &gt;&gt;</b> 0.5 to 100.0 sec (Default : 10.0 sec)	<b>HZ Prop Band &gt;&gt;</b> Proportional Band for Heat Pre-dominant zone 0.1 to 999.9 (Default : 50.0)
<b>Overshoot Inhibit &gt;&gt;</b> Enable Disable (Default : Disable)	<b>Overshoot Inhibit &gt;&gt;</b> Enable Disable (Default : Disable)	<b>HZ Integral Time &gt;&gt;</b> Integral Time for Heat Pre-dominant zone 0 to 3600 sec (Default : 100 sec)
<b>Cutoff Factor &gt;&gt;</b> 1.0 to 2.0 sec (Default : 1.2 sec)	<b>Cutoff Factor &gt;&gt;</b> 1.0 to 2.0 sec (Default : 1.2 sec)	<b>HZ Derivative Time &gt;&gt;</b> Derivative Time for Heat Pre-dominant zone 0 to 600 sec (Default : 16 sec)
		<b>Cycle Time &gt;&gt;</b> 0.5 to 100.0 sec (Default : 10.0 sec)
		<b>Overshoot Inhibit &gt;&gt;</b> Enable Disable (Default : Disable)
		<b>Cutoff Factor &gt;&gt;</b> 1.0 to 2.0 sec (Default : 1.2 sec)

SUPERVISORY > PRINTER SETTING	
Parameters	Settings (Default Value)
Line Per Page >>	25 to 100 (Default : 65)
Top Margine >>	1 to 5 (Default : 2)
Bottom Margine >>	1 to 5 (Default : 2)
Header & Footer >>	No On First Page Every Page (Default : No)
Enable >>	Yes No (Default : No)

SUPERVISORY > PRINT EVENT	
Parameters	Settings (Default Value)
Alarm Toggle >>	
RTC Modify >>	Yes No (Default : Yes)
Interval Modify >>	
Power Up >>	
Door Open >>	
Mains Fail >>	
Setpoint Modify >>	

SUPERVISORY > PASSWORD	
Parameters	Settings (Default Value)
Change Password >>	1000 to 1999 (Default : 123)

SUPERVISORY > EXIT	
Parameters	Settings (Default Value)
Exit Setup Mode >>	Yes No (Default : No)

FACTORY > CONTROL SENSOR INPUT			
Parameters	Settings (Default Value)		
Input Type >>	Refer Table 1 (Default : RTD Pt100)		
Signal LO >>	Input Type	Settings	Default
	0 to 20mA	0.00 to Signal High	0.00
	4 to 20mA	4.00 to Signal High	4.00
	0 to 5V	0.000 to Signal High	0.000
	0 to 10V	0.00 to Signal High	0.00
Signal HI >>	Input Type	Settings	Default
	0 to 20mA	Signal Low to 20.00	20.00
	4 to 20mA	Signal Low to 20.00	20.00
	0 to 5V	Signal Low to 5.000	5.000
	0 to 10V	Signal Low to 10.00	10.00
Range LO >>	-199.9 to RANGE HI (Default : 0.0)		
	RANGE LO to 999.9 (Default : 100.0)		

FACTORY > ALARM PARAMETERS	
Parameters	Settings (Default Value)
Hysteresis >>	0.1 to 99.9 (Default : 0.2)
Inhibit >>	Yes No (Default : Yes)

FACTORY > HEAT COOL SELECT			
Parameters	Settings (Default Value)		
Control Strategy >>	Heat Only Cool Only Heat + Cool (Default : Heat + Cool)		
Control Strategy : Cool Only			
Time Delay (sec) >>	0 to 1000 Sec (Default : 200 Sec)		
Control Strategy : Heat + Cool			
Compressor Strategy >>	CONT. OFF CONT. ON SP BASED PV BASED (Default : CONT. ON)		
CONT. ON		SP BASED	PV BASED
Time Delay (sec) >>	Boundary Set Value >>	Time Delay (sec) >>	
0 to 1000 Sec (Default : 200 Sec)	0 to 100 (Resolution 0.1°C for RTD / DC Linear & 1°C for Thermocouple) (Default : 45.0)	0 to 1000 Sec (Default : 200 Sec)	
Control Zones >>			
Single Dual (Default : Single)			
Time Delay (sec) >>			
0 to 1000 Sec (Default : 200 Sec)			

FACTORY > SOAK TIMER PARAMETERS	
Parameters	Settings (Default Value)
Enable >>	No Yes (Default : No)
Start Band >>	0 to 999.9 (Default : 0.5)
Holdback Strategy >>	None Up Down Both (Default : None)
Hold Band >>	0.1 to 999.9 (Default : 0.5)
Heat Off >>	No Yes (Default : No)
Cool Off >>	No Yes (Default : No)
Power Recovery >>	Abort Restart Continuous (Default : Restart)

FACTORY > DOOR OPEN	
Parameters	Settings (Default Value)
Enable >>	Yes No (Default : No)
Switch Logic >>	Close : Door Open Open : Door Open (Default : Close : Door Open)
Door Alarm Dly (sec) >>	0 to 1000 Sec (Default : 60 Sec)

FACTORY > MAINS FAILURE	
Parameters	Settings (Default Value)
Enable >>	Yes No (Default : No)
Switch Logic >>	Close : Mains Fail Open : Mains Fail (Default : Close : Mains Fail)

FACTORY > PASSWORD	
Parameters	Settings (Default Value)
Change Password >>	2000 to 2999 (Default : 321)

FACTORY > FACTORY DEFAULT	
Parameters	Settings (Default Value)
Set To Default >>	Yes No (Default : No)

FACTORY > EXIT	
Parameters	Settings (Default Value)
Exit Setup Mode >>	Yes No (Default : No)

TABLE 1			
What it means	Range (Min. to Max.)	Resolution	
Type J Thermocouple	0 to +960°C	Fixed 1°C	
Type K Thermocouple	-200 to +1376°C		
Type T Thermocouple	-200 to +385°C		
Type R Thermocouple	0 to +1770°C		
Type S Thermocouple	0 to +1765°C		
Type B Thermocouple	0 to +1825°C		
Type N Thermocouple	0 to +1300°C	Fixed 0.1 unit	
Reserve	Reserved for customer specific Thermocouple type not listed above. The type shall be specified in accordance with the ordered (optional on request) Thermocouple type.		
3-wire, RTD Pt100	-199.9 to 600.0°C		Fixed 0.1°C
0 to 20mA DC current	-199.9 to 999.9 units		Fixed 0.1 unit
4 to 20mA DC current			
0 to 5.0V DC voltage			
0 to 10.0V DC voltage			
1 to 5.0V DC voltage			

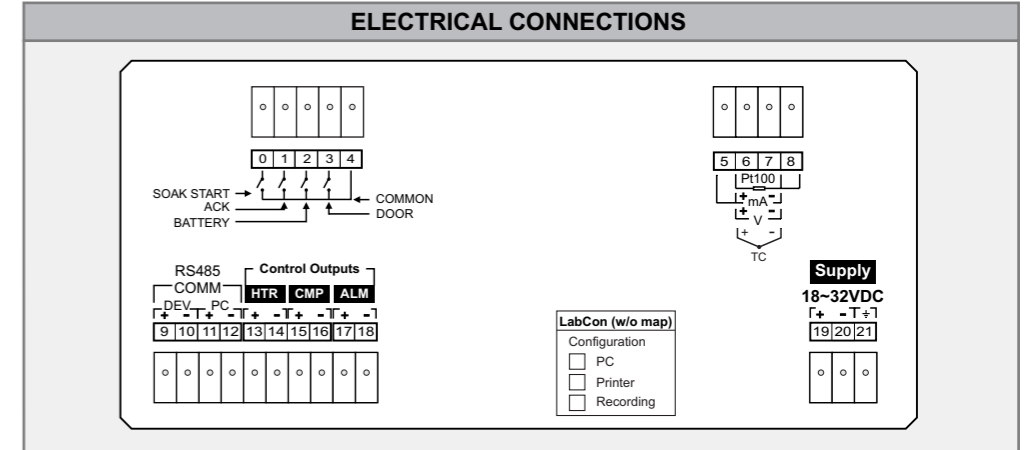

### PV ERROR INDICATIONS

Message	Error Type	Cause
<b>OPEN</b>	Sensor Open	Sensor (RTD Pt100) Broken / Open
<b>OVR</b>	Over-range	Temperature above Max. Specified Range
<b>UNR</b>	Under-range	Temperature below Min. Specified Range

### FRONT PANEL KEYS

Symbol	Key	Function
	Scroll	Press to scroll through various Process Information Screens in Normal Operation Mode.
	Alarm Acknowledge	Press to acknowledge and mute (if active) alarm output.
	DOWN	Press to decrease the parameter value. Pressing once decreases the value by one count; keeping pressed speeds up the change.
	UP	Press to increase the parameter value. Pressing once increases the value by one count; keeping pressed speeds up the change.
	SET-UP	Press to enter or exit set-up mode.
	ENTER	Press to store the set parameter value and to scroll to the next parameter.