

AIMS-4/8X

4 / 8 Channel DIN-Rail Analog Input Modules
 MODBUS over RS485 Serial Interface
 (Single-Ended & Differential Input Versions)

Operation Manual

This brief manual is primarily meant for quick reference to wiring connections and parameter searching. For more details on operation and application; please log on to www.ppiindia.net

101, Diamond Industrial Estate, Navghar,
 Vasai Road (E), Dist. Palghar - 401 210.
 Sales : 8208199048 / 8208141446
 Support : 07498799226 / 08767395333
 E: sales@ppiindia.net, support@ppiindia.net

Jan 2022

Input Registers (Read-Only Parameters)										
Parameter	MODBUS Address	Values								
Process Value	1561 to 1564 (4 Channels)	<table border="1"> <thead> <tr> <th>Value</th> <th>PV Error Type</th> </tr> </thead> <tbody> <tr> <td>-32768</td> <td>Under Range</td> </tr> <tr> <td>+32752</td> <td>Over Range</td> </tr> <tr> <td>+32767</td> <td>Sensor Open</td> </tr> </tbody> </table>	Value	PV Error Type	-32768	Under Range	+32752	Over Range	+32767	Sensor Open
	Value	PV Error Type								
-32768	Under Range									
+32752	Over Range									
+32767	Sensor Open									
	1561 to 1568 (8 Channels)									
Alarm-1 Status	1577	<table border="1"> <thead> <tr> <th>Bit 15</th> <th>Bit 7</th> <th>Bit 1</th> <th>Bit 0</th> </tr> </thead> <tbody> <tr> <td></td> <td></td> <td></td> <td></td> </tr> </tbody> </table> <p>(X = 1, 2, 3, 4) Alarm-X Status for Channel-1 Alarm-X Status for Channel-2 Alarm-X Status for Channel-8</p>	Bit 15	Bit 7	Bit 1	Bit 0				
Bit 15	Bit 7	Bit 1	Bit 0							
Alarm-2 Status	1578									
Alarm-3 Status	1579									
Alarm-4 Status	1580	<table border="1"> <thead> <tr> <th>Bit Value</th> <th>Status</th> </tr> </thead> <tbody> <tr> <td>0</td> <td>Alarm OFF</td> </tr> <tr> <td>1</td> <td>Alarm ON</td> </tr> </tbody> </table> <p>For 4 Channel Version (AIMS-4X), ignore Bit-4 to Bit-15 For 8 Channel Version (AIMS-8X), ignore Bit-8 to Bit-15</p>	Bit Value	Status	0	Alarm OFF	1	Alarm ON		
Bit Value	Status									
0	Alarm OFF									
1	Alarm ON									
Ambient Temperature	82	<p>Signed integer values from -30000 to +30000 representing the measured Ambient Temperature through the semi-conductor sensor mounted on the Module.</p> <p>The measured value is always in °C with 0.1 resolution. For example, 30.0°C is represented as 300.</p>								

Holding Registers (Read / Write Parameters)																																						
Parameter	MODBUS Address	Settings (Default Value)																																				
Input Type	83 to 86 (4 Channels)	Applicable for Input Type TC / RTD Pt100 / V / mV / mA																																				
	83 to 90 (8 Channels)	<table border="1"> <thead> <tr> <th>Value</th> <th>Type</th> </tr> </thead> <tbody> <tr><td>0</td><td>Type J Thermocouple</td></tr> <tr><td>1</td><td>Type K Thermocouple</td></tr> <tr><td>2</td><td>Type T Thermocouple</td></tr> <tr><td>3</td><td>Type R Thermocouple</td></tr> <tr><td>4</td><td>Type S Thermocouple</td></tr> <tr><td>5</td><td>Type B Thermocouple</td></tr> <tr><td>6</td><td>Type N Thermocouple</td></tr> <tr><td>7</td><td>Reserved TC (Default: Type J)</td></tr> <tr><td>8</td><td>RTD Pt100, 3-wire</td></tr> <tr><td>9</td><td>0 to 20 mA</td></tr> <tr><td>10</td><td>4 to 20 mA</td></tr> <tr><td>11</td><td>0 to 80 mV</td></tr> <tr><td>12</td><td>Reserved (Default: 0 to 80 mV)</td></tr> <tr><td>13</td><td>0 to 1.25 V</td></tr> <tr><td>14</td><td>0 to 5 V</td></tr> <tr><td>15</td><td>0 to 10 V</td></tr> <tr><td>16</td><td>1 to 5 V</td></tr> </tbody> </table> <p>(Default : 0 to 10 V)</p>	Value	Type	0	Type J Thermocouple	1	Type K Thermocouple	2	Type T Thermocouple	3	Type R Thermocouple	4	Type S Thermocouple	5	Type B Thermocouple	6	Type N Thermocouple	7	Reserved TC (Default: Type J)	8	RTD Pt100, 3-wire	9	0 to 20 mA	10	4 to 20 mA	11	0 to 80 mV	12	Reserved (Default: 0 to 80 mV)	13	0 to 1.25 V	14	0 to 5 V	15	0 to 10 V	16	1 to 5 V
	Value	Type																																				
	0	Type J Thermocouple																																				
	1	Type K Thermocouple																																				
	2	Type T Thermocouple																																				
	3	Type R Thermocouple																																				
	4	Type S Thermocouple																																				
	5	Type B Thermocouple																																				
	6	Type N Thermocouple																																				
	7	Reserved TC (Default: Type J)																																				
	8	RTD Pt100, 3-wire																																				
	9	0 to 20 mA																																				
	10	4 to 20 mA																																				
	11	0 to 80 mV																																				
	12	Reserved (Default: 0 to 80 mV)																																				
13	0 to 1.25 V																																					
14	0 to 5 V																																					
15	0 to 10 V																																					
16	1 to 5 V																																					
		Applicable for Input Type RTD Pt100																																				
		<table border="1"> <thead> <tr> <th>Value</th> <th>Type</th> </tr> </thead> <tbody> <tr> <td>0</td> <td>RTD Pt100, 3-wire (This is a Read Only parameter)</td> </tr> </tbody> </table>	Value	Type	0	RTD Pt100, 3-wire (This is a Read Only parameter)																																
Value	Type																																					
0	RTD Pt100, 3-wire (This is a Read Only parameter)																																					
		Applicable for Input Type TC / mV																																				
		<table border="1"> <thead> <tr> <th>Value</th> <th>Type</th> </tr> </thead> <tbody> <tr><td>0</td><td>Type J Thermocouple</td></tr> <tr><td>1</td><td>Type K Thermocouple</td></tr> <tr><td>2</td><td>Type T Thermocouple</td></tr> <tr><td>3</td><td>Type R Thermocouple</td></tr> <tr><td>4</td><td>Type S Thermocouple</td></tr> <tr><td>5</td><td>Type B Thermocouple</td></tr> <tr><td>6</td><td>Type N Thermocouple</td></tr> <tr><td>7</td><td>Reserved TC (Default: Type J)</td></tr> <tr><td>8</td><td>0 to 80 mV</td></tr> </tbody> </table> <p>(Default : Type K)</p>	Value	Type	0	Type J Thermocouple	1	Type K Thermocouple	2	Type T Thermocouple	3	Type R Thermocouple	4	Type S Thermocouple	5	Type B Thermocouple	6	Type N Thermocouple	7	Reserved TC (Default: Type J)	8	0 to 80 mV																
Value	Type																																					
0	Type J Thermocouple																																					
1	Type K Thermocouple																																					
2	Type T Thermocouple																																					
3	Type R Thermocouple																																					
4	Type S Thermocouple																																					
5	Type B Thermocouple																																					
6	Type N Thermocouple																																					
7	Reserved TC (Default: Type J)																																					
8	0 to 80 mV																																					

Parameter	MODBUS Address	Settings (Default Value)																								
Input Type	83 to 86 (4 Channels)	Applicable for Input Type V / mA																								
	83 to 90 (8 Channels)	<table border="1"> <thead> <tr> <th>Value</th> <th>Type</th> </tr> </thead> <tbody> <tr><td>0</td><td>0 to 20 mA</td></tr> <tr><td>1</td><td>4 to 20 mA</td></tr> <tr><td>2</td><td>0 to 1.25 V</td></tr> <tr><td>3</td><td>0 to 5 V</td></tr> <tr><td>4</td><td>0 to 10 V</td></tr> <tr><td>5</td><td>1 to 5 V</td></tr> </tbody> </table> <p>(Default : 0 to 10 V)</p>	Value	Type	0	0 to 20 mA	1	4 to 20 mA	2	0 to 1.25 V	3	0 to 5 V	4	0 to 10 V	5	1 to 5 V										
Value	Type																									
0	0 to 20 mA																									
1	4 to 20 mA																									
2	0 to 1.25 V																									
3	0 to 5 V																									
4	0 to 10 V																									
5	1 to 5 V																									
Temperature Units	99 to 102 (4 Channels) 99 to 106 (8 Channels)	<p>Conditional Parameter (Note 2)</p> <table border="1"> <thead> <tr> <th>Value</th> <th>Unit</th> </tr> </thead> <tbody> <tr><td>0</td><td>°C</td></tr> <tr><td>1</td><td>°F</td></tr> </tbody> </table> <p>(Default : °C)</p>	Value	Unit	0	°C	1	°F																		
Value	Unit																									
0	°C																									
1	°F																									
DC Resolution (Note 1)	115 to 118 (4 Channels) 115 to 122 (8 Channels)	<p>Conditional Parameter (Note 2)</p> <table border="1"> <thead> <tr> <th>Value</th> <th>Resolution</th> </tr> </thead> <tbody> <tr><td>0</td><td>1</td></tr> <tr><td>1</td><td>0.1</td></tr> <tr><td>2</td><td>0.01</td></tr> <tr><td>3</td><td>0.001</td></tr> <tr><td>4</td><td>0.0001</td></tr> </tbody> </table> <p>(Default : 1 Unit for DC Linear input & 0.1 for Thermocouple & RTD)</p>	Value	Resolution	0	1	1	0.1	2	0.01	3	0.001	4	0.0001												
Value	Resolution																									
0	1																									
1	0.1																									
2	0.01																									
3	0.001																									
4	0.0001																									
Signal Low	501 to 504 (4 Channels)	Conditional Parameter (Note 2)																								
	501 to 508 (8 Channels)	<table border="1"> <thead> <tr> <th>Input Type</th> <th>Settings</th> <th>Default</th> </tr> </thead> <tbody> <tr><td>0 to 20 mA</td><td>0.00 to Signal High</td><td>0.00</td></tr> <tr><td>4 to 20 mA</td><td>4.00 to Signal High</td><td>4.00</td></tr> <tr><td>0 to 80 mV</td><td>0.00 to Signal High</td><td>0.00</td></tr> <tr><td>0 to 1.25 V</td><td>0.000 to Signal High</td><td>0.000</td></tr> <tr><td>0 to 5 V</td><td>0.000 to Signal High</td><td>0.000</td></tr> <tr><td>0 to 10 V</td><td>0.00 to Signal High</td><td>0.00</td></tr> <tr><td>1 to 5 V</td><td>1.000 to Signal High</td><td>1.000</td></tr> </tbody> </table>	Input Type	Settings	Default	0 to 20 mA	0.00 to Signal High	0.00	4 to 20 mA	4.00 to Signal High	4.00	0 to 80 mV	0.00 to Signal High	0.00	0 to 1.25 V	0.000 to Signal High	0.000	0 to 5 V	0.000 to Signal High	0.000	0 to 10 V	0.00 to Signal High	0.00	1 to 5 V	1.000 to Signal High	1.000
Input Type	Settings	Default																								
0 to 20 mA	0.00 to Signal High	0.00																								
4 to 20 mA	4.00 to Signal High	4.00																								
0 to 80 mV	0.00 to Signal High	0.00																								
0 to 1.25 V	0.000 to Signal High	0.000																								
0 to 5 V	0.000 to Signal High	0.000																								
0 to 10 V	0.00 to Signal High	0.00																								
1 to 5 V	1.000 to Signal High	1.000																								
Signal High	517 to 520 (4 Channels) 517 to 524 (8 Channels)	<p>Conditional Parameter (Note 2)</p> <table border="1"> <thead> <tr> <th>Input Type</th> <th>Settings</th> <th>Default</th> </tr> </thead> <tbody> <tr><td>0 to 20 mA</td><td>Signal Low to 20.00</td><td>20.00</td></tr> <tr><td>4 to 20 mA</td><td>Signal Low to 20.00</td><td>20.00</td></tr> <tr><td>0 to 80 mV</td><td>Signal Low to 80.00</td><td>80.00</td></tr> <tr><td>0 to 1.25 V</td><td>Signal Low to 1.250</td><td>1.250</td></tr> <tr><td>0 to 5 V</td><td>Signal Low to 5.000</td><td>5.000</td></tr> <tr><td>0 to 10 V</td><td>Signal Low to 10.00</td><td>10.00</td></tr> <tr><td>1 to 5 V</td><td>Signal Low to 5.000</td><td>5.000</td></tr> </tbody> </table>	Input Type	Settings	Default	0 to 20 mA	Signal Low to 20.00	20.00	4 to 20 mA	Signal Low to 20.00	20.00	0 to 80 mV	Signal Low to 80.00	80.00	0 to 1.25 V	Signal Low to 1.250	1.250	0 to 5 V	Signal Low to 5.000	5.000	0 to 10 V	Signal Low to 10.00	10.00	1 to 5 V	Signal Low to 5.000	5.000
Input Type	Settings	Default																								
0 to 20 mA	Signal Low to 20.00	20.00																								
4 to 20 mA	Signal Low to 20.00	20.00																								
0 to 80 mV	Signal Low to 80.00	80.00																								
0 to 1.25 V	Signal Low to 1.250	1.250																								
0 to 5 V	Signal Low to 5.000	5.000																								
0 to 10 V	Signal Low to 10.00	10.00																								
1 to 5 V	Signal Low to 5.000	5.000																								
Range Low	131 to 134 (4 Channels) 131 to 138 (8 Channels)	<p>Conditional Parameter (Note 2)</p> <p>-30000 to 30000 (Default : 0)</p>																								
Range High	147 to 150 (4 Channels) 147 to 154 (8 Channels)	<p>Conditional Parameter (Note 2)</p> <p>-30000 to 30000 (Default : 1000)</p>																								
Offset for PV (Note 1)	163 to 166 (4 Channels) 163 to 170 (8 Channels)	-30000 to 30000 (Default : 0)																								
Alarm-1 Type	179 to 182 (4 Channels) 179 to 186 (8 Channels)																									
Alarm-2 Type	243 to 246 (4 Channels)																									
	243 to 250 (8 Channels)	<table border="1"> <thead> <tr> <th>Value</th> <th>Type</th> </tr> </thead> <tbody> <tr><td>0</td><td>None</td></tr> <tr><td>1</td><td>Process Low</td></tr> <tr><td>2</td><td>Process High</td></tr> </tbody> </table> <p>(Default : None)</p>	Value	Type	0	None	1	Process Low	2	Process High																
Value	Type																									
0	None																									
1	Process Low																									
2	Process High																									
Alarm-3 Type	307 to 310 (4 Channels)																									
	307 to 314 (8 Channels)																									
Alarm-4 Type	371 to 374 (4 Channels)																									
	371 to 378 (8 Channels)																									

Parameter	MODBUS Address	Settings (Default Value)																
Alarm-1 Set-point (Note 1)	195 to 198 (4 Channels)	Min. to Max. Range specified for the selected Input Type Refer Table 1 (Default : Min or Max Range depending on the Alarm type)																
	195 to 202 (8 Channels)																	
Alarm-2 Set-point (Note 1)	259 to 262 (4 Channels)																	
	259 to 266 (8 Channels)																	
Alarm-3 Set-point (Note 1)	323 to 326 (4 Channels)																	
	323 to 330 (8 Channels)																	
Alarm-4 Set-point (Note 1)	387 to 390 (4 Channels)																	
	387 to 394 (8 Channels)																	
Alarm-1 Hysteresis (Note 1)	211 to 214 (4 Channels)		1 to 30000 (Default : 20)															
	211 to 218 (8 Channels)																	
Alarm-2 Hysteresis (Note 1)	275 to 278 (4 Channels)																	
	275 to 282 (8 Channels)																	
Alarm-3 Hysteresis (Note 1)	339 to 342 (4 Channels)																	
	339 to 346 (8 Channels)																	
Alarm-4 Hysteresis (Note 1)	403 to 406 (4 Channels)																	
	403 to 410 (8 Channels)																	
Alarm-1 Inhibit	227 to 230 (4 Channels)	<table border="1"> <thead> <tr> <th>Value</th> <th>Inhibit</th> </tr> </thead> <tbody> <tr><td>0</td><td>Disable</td></tr> <tr><td>1</td><td>Enable</td></tr> </tbody> </table> <p>(Default : Disable)</p>		Value	Inhibit	0	Disable	1	Enable									
	Value			Inhibit														
0	Disable																	
1	Enable																	
227 to 234 (8 Channels)																		
Alarm-2 Inhibit	291 to 294 (4 Channels)																	
	291 to 298 (8 Channels)																	
Alarm-3 Inhibit	355 to 358 (4 Channels)																	
	355 to 362 (8 Channels)																	
Alarm-4 Inhibit	419 to 422 (4 Channels)																	
	419 to 426 (8 Channels)																	
Enable Bottom Clipping	435 to 438 (4 Channels) 435 to 442 (8 Channels)		<table border="1"> <thead> <tr> <th>Value</th> <th>Enable</th> </tr> </thead> <tbody> <tr><td>0</td><td>No</td></tr> <tr><td>1</td><td>Yes</td></tr> </tbody> </table> <p>(Default : No)</p>	Value	Enable	0	No	1	Yes									
Value	Enable																	
0	No																	
1	Yes																	
Bottom Clip Value	451 to 454 (4 Channels) 451 to 458 (8 Channels)		-30000 to 30000 (Default : 0)															
Enable Top Clipping	467 to 470 (4 Channels) 467 to 474 (8 Channels)	<table border="1"> <thead> <tr> <th>Value</th> <th>Enable</th> </tr> </thead> <tbody> <tr><td>0</td><td>No</td></tr> <tr><td>1</td><td>Yes</td></tr> </tbody> </table> <p>(Default : No)</p>	Value	Enable	0	No	1	Yes										
Value	Enable																	
0	No																	
1	Yes																	
Top Clip Value	483 to 486 (4 Channels) 483 to 490 (8 Channels)	-30000 to 30000 (Default : 1000)																
Configuring Communication Parameters																		
Parameter	MODBUS Address	Settings (Default Value)																
Modbus Slave ID	1	1 to 247 (Default : 1)																
Baud Rate	2	<table border="1"> <thead> <tr> <th>Value</th> <th>Baud Rate</th> </tr> </thead> <tbody> <tr><td>0</td><td>2400 bps</td></tr> <tr><td>1</td><td>4800 bps</td></tr> <tr><td>2</td><td>9600 bps</td></tr> <tr><td>3</td><td>19200 bps</td></tr> <tr><td>4</td><td>38400 bps</td></tr> <tr><td>5</td><td>57600 bps</td></tr> <tr><td>6</td><td>115200 bps</td></tr> </tbody> </table> <p>(Default : 9600 bps)</p>	Value	Baud Rate	0	2400 bps	1	4800 bps	2	9600 bps	3	19200 bps	4	38400 bps	5	57600 bps	6	115200 bps
		Value	Baud Rate															
		0	2400 bps															
		1	4800 bps															
		2	9600 bps															
		3	19200 bps															
		4	38400 bps															
5	57600 bps																	
6	115200 bps																	
Parity	3	<table border="1"> <thead> <tr> <th>Value</th> <th>Parity</th> </tr> </thead> <tbody> <tr><td>0</td><td>None</td></tr> <tr><td>1</td><td>Even</td></tr> <tr><td>2</td><td>Odd</td></tr> </tbody> </table> <p>(Default : Even)</p>	Value	Parity	0	None	1	Even	2	Odd								
		Value	Parity															
		0	None															
1	Even																	
2	Odd																	

Note 1

Thermocouples (J, K, T, R, S, B, N) and RTD Pt100 (3-wire) Inputs

The process value is always measured in 0.1°C/°F resolution. That is, for example, the value 300 means 30.0°C / °F.

The same should be followed while setting the values for the parameters that are resolution based (like Zero Offset, Alarm Set-point, Alarm Hysteresis, etc.). That is for example, set 300 counts for 30.0°C / °F.

DC mA / mV / V Inputs

(Also Refer Appendix A: DC Linear Signal Interface)

The measured PV is a Resolution-less Scaled Value derived using the values for the parameters : Signal Low, Signal High, Range Low and Range High. The parameter 'DC Resolution' holds the desired resolution that can be used to insert appropriate Decimal Place in the scaled PV. For example, if the DC Resolution value is 2 (0.01) then the scaled value of 3000 can be read as 30.00.

Similarly the corresponding parameters like Zero Offset, Alarm Set-point, Alarm Hysteresis, etc., are also resolution less and, if desired, the parameter value for 'DC Resolution' should be used for appropriate Decimal Place.

Note 2

Conditional Parameters are those whose usage depend upon the values set for some other parameters. For example; the parameters 'Signal Low' & 'Signal High' for a selected channel are used only if the input type for the selected channel is DC Input (mV / V / mA). The access to the conditional parameters for Read / Write operation, however, is not restricted.

Table 1			
Input Type	Range (Min. to Max.)	Resolution	
Type J Thermocouple	0 to +960.0°C / +32.0 to +1760.0°F	0.1 °C / °F	
Type K Thermocouple	-200.0 to +1376.0°C / -328.0 to +2508.0°F		
Type T Thermocouple	-200.0 to +387.0°C / -328.0 to +728.0°F		
Type R Thermocouple	0 to +1771.0°C / +32.0 to +3219.0°F		
Type S Thermocouple	0 to +1768.0°C / +32.0 to +3214.0°F		
Type B Thermocouple	0 to +1826.0°C / +32.0 to +3218.0°F		
Type N Thermocouple	0 to +1314.0°C / +32.0 to +2397.0°F		
3-wire, RTD Pt100	-199.0 to +600.0°C / -328.0 to +1112.0°F		
0 to 20mA DC current	-30000 to 30000 units		1
4 to 20mA DC current			
0 to 80mV DC voltage		0.1	
0 to 1.25V DC voltage		0.001	
0 to 5.0V DC voltage		0.0001	
0 to 10.0V DC voltage		Units	
1 to 5.0V DC voltage			

CONFIGURING COMMUNICATION

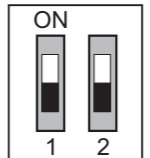
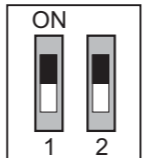
Switch Position	 Down	 Up
Mode Indicator	OFF	ON
Operation Mode	Normal	Configuration
Communication Parameter Values	User Set values for Module Slave ID, Baud Rate & Parity	Module Slave ID : 1 Baud Rate : 9600 Parity : Even

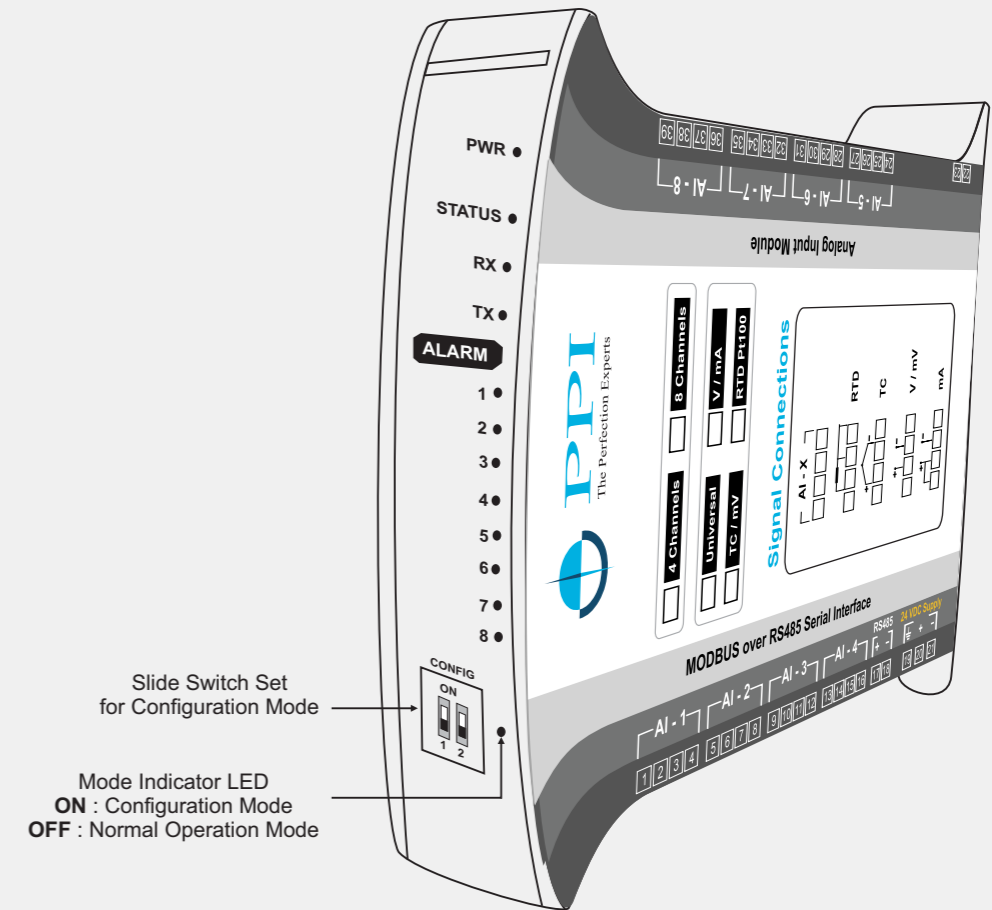

OVERALL DIMENSION

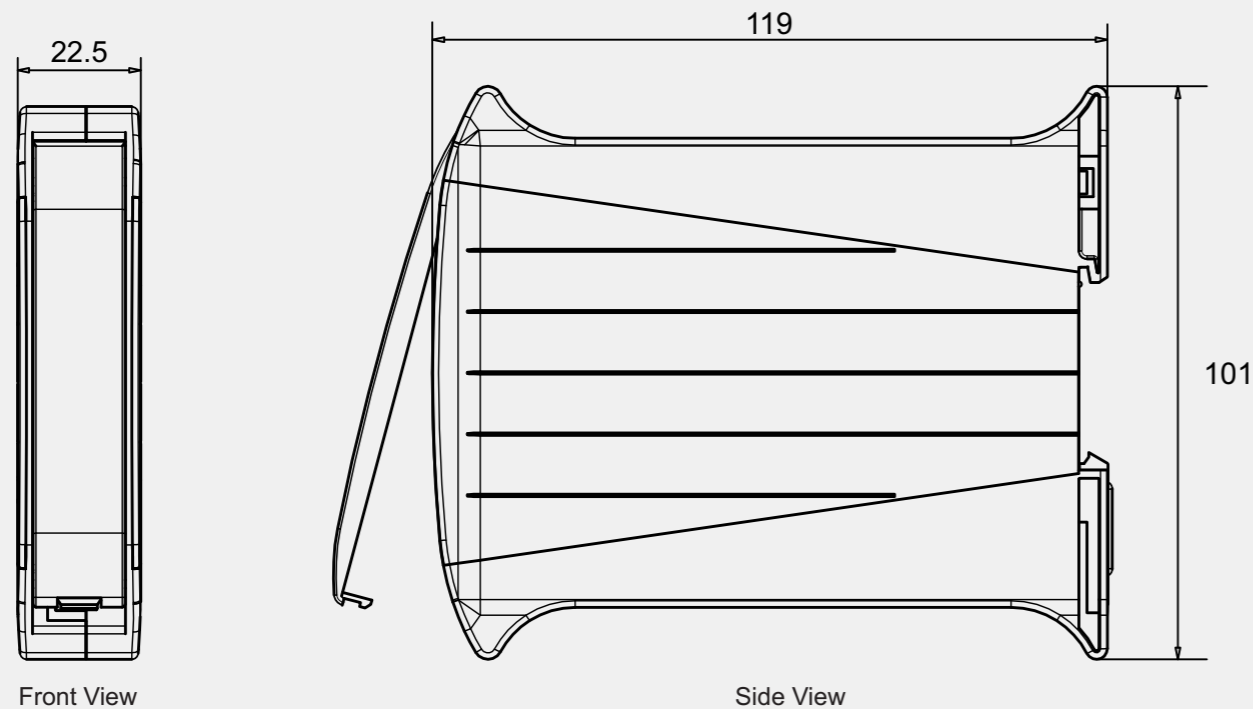

Width (W) : 22.5 mm	Height (H) : 101.0 mm	Depth (D) : 119.0 mm
---------------------	-----------------------	----------------------

ELECTRICAL CONNECTIONS

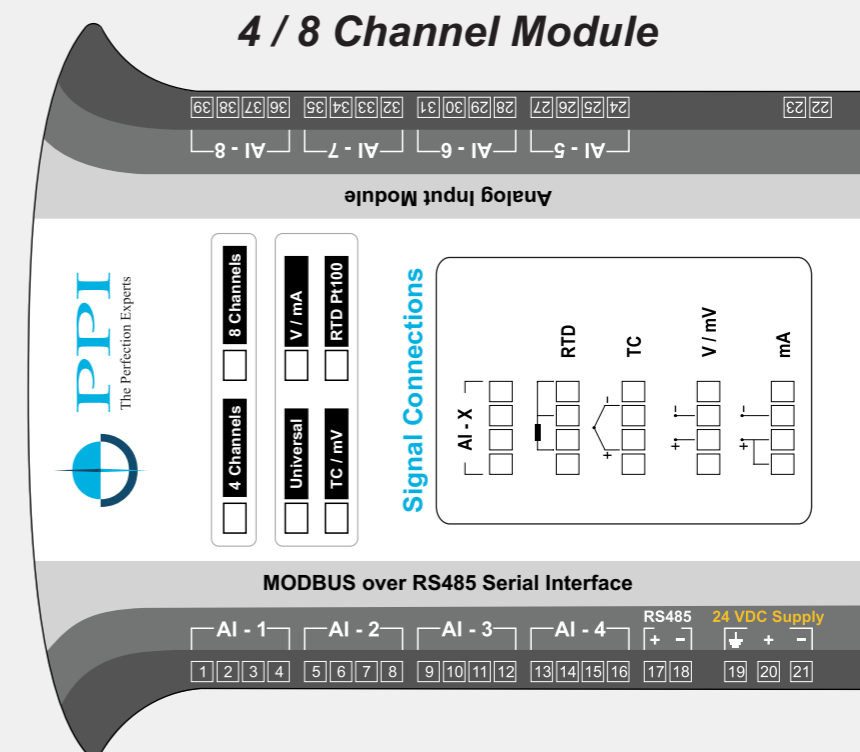

Note : For 4 Channel Version the connectors for AI-5 to AI-8 are not fitted.