

UniLog / UniLog Plus with AIS

Universal Process Data Recorder Pen-Drive Version

Operation Manual

This brief manual is primarily meant for quick reference to wiring connections and parameter searching. For more details on operation and application; please log on to www.ppiindia.net

101, Diamond Industrial Estate, Navghar, Vasai Road (E), Dist. Palghar - 401 210.
 Sales : 8208199048 / 8208141446
 Support : 07498799226 / 08767395333
 E: sales@ppiindia.net, support@ppiindia.net

Jan 2022

OPERATOR PARAMETERS	
Parameters	Settings (Default Value)
Select Option for Operation on Pen Drive SELECT OPTION>> None	None Copy (New) Re-copy (Old) Read Chan Names Recover (Default : None)
'Start' Command for Batch Recording (Available if Batch Recording is selected) BATCH START>> NO	No Yes (Default : No)
'Stop' Command for Batch Recording (Available if Batch Recording is selected) BATCH STOP>> NO	No Yes (Default : No)

DEVICE CONFIGURATION	
Parameters	Settings (Default Value)
Channel Update Time in Auto Scan Mode SCAN RATE>> 3	1 Sec. to 99 Sec. (Default : 3 Sec.)
Device Identification Number RECORDER ID>> 2	1 to 127 (Default : 1)
Select Total Numbers of Channels TOTAL CHANNELS>> 16	8 16 (Default : 16)
Erase All Stored Records DELETE RECORDS>> No	No Yes (Default : No)

Parameters	Settings (Default Value)
Select Break - Point Number for Setting SELECT POINT>> 1	1 to Set Numbers of Break-points (Default : NA)
X Co-ordinate Value X-VALUE>> 0	-19999 to 30000 (Default : 0)
Y Co-ordinate Value Y-VALUE>> 0	-19999 to 30000 (Default : 0)

UTILITIES	
Parameters	Settings
UIM Default UIM DEFAULT>> No	No Yes
CIM Default CIM DEFAULT>> No	No Yes
*Set Device Id SET DEVICE ID>> 1	No Yes
Make CIM & UIM Compatible CPY CIM TO UIM>> No	No Yes
CPY UIM TO CIM>> No	No Yes

TABLE- 2		
Option	Range (Min. to Max.)	Resolution
EC-U J Type T/C	0 to +960°C / +32 to +1760°F	Fixed 1°C / 1°F
EC-P K Type T/C	-200 to +1376°C / -328 to +2508°F	
EC-E T Type T/C	-200 to +385°C / -328 to +728°F	
EC-R R Type T/C	0 to +1771°C / +32.0 to +3219°F	
EC-S S Type T/C	0 to +1768°C / +32 to +3214°F	
EC-b B Type T/C	0 to +1826°C / +32.0 to +3218°F	User settable 1°C / 1°F or 0.1°C / 0.1°F
EC-n N Type T/C	0 to +1314.0°C / +32 to +2397.0°F	
RESU	Reserved for customer specific Thermocouple type not listed above.	
rtd RTD Pt100	-199 to +600°C / -328 to +1112°F or -199.9 to 600.0°C / -328.0 to 1112.0°F	
0-20 0 to 20mA DC	-19999 to +30000 units	
4-20 4 to 20mA DC		
0050 0 to 50mV DC		
0200 0 to 200mV DC		
1.25 0 to 1.25V DC		
5.0 0 to 5.0V DC		
10.0 0 to 10.0V DC		
1-5 1 to 5.0V DC		

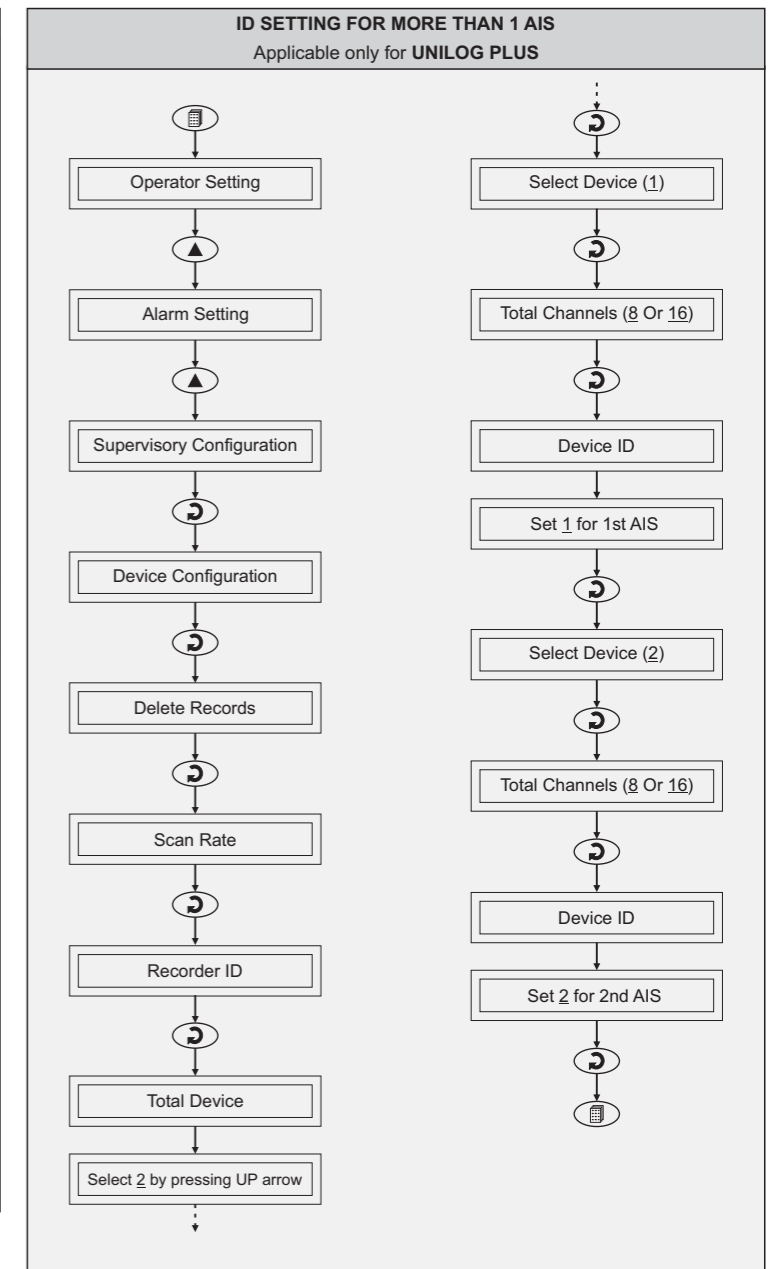

SUPERVISORY CONFIGURATION	
Boiler Temp. 91°C MAIN Display Mode	SELECT PAGE>> Operator Page First Available Page Header
SELECT PAGE>> Sprv. Config	ENTER PASSCODE>> 0 Passcode Screen
ENTER PASSCODE>> 22	SELECT PAGE>> Device Config First Supervisory Page Header
SELECT PAGE>> Alarm Config	ALARMS / CHAN>> 4 First Alarms Config Parameter

CHANNEL CONFIGURATION	
Parameters	Settings (Default Value)
Select Channel Name SELECT CHANNEL>> Channel-1	User defined or default names for channel-1 to channel - 8 / 16 (Default : NA)
Skip Channel for Display SKIP>> No	No Yes (Default : Yes)
Signal Input Type INPUT TYPE>> Type K (Cr-Al)	Refer Table 2 (Default : Type K (Cr-Al))
Display Resolution for Measured PV RESOLUTION>> 0.1 Unit	1 Unit 0.1 Unit 0.01 Unit * 0.001 Unit * (Default : 0.1 Unit) (* for 4-20mA)
Display Units for Measured PV UNITS>> °C	Refer Table 1 (Default : °C)
Range Low (for 4-20mA) RANGE LOW>> 0	-19999 to 30000 Counts with Selected Resolution (Default : 0.0)
Range High (for 4-20mA) RANGE HIGH>> 1000	-19999 to 30000 Counts with Selected Resolution (Default : 100.0)
Apply Lower Clip on Displayed PV (for 4-20mA) LOW CLIPPING>> Disable	Disable Enable (Default : Disable)
Preset Lower Clip Level (for 4-20mA) LOW CLIP VAL>> 0.0	-19999 to 30000 (Default : 0)
Apply Upper Clip on Displayed PV (for 4-20mA) HIGH CLIPPING>> Disable	Disable Enable (Default : Disable)
Preset Upper Clip Level (for 4-20mA) HIGH CLIP VAL>> 100.0	-19999 to 30000 (Default : 100.0)
Zero Offset ZERO OFFSET>> 0	-1999 / 3000 or -1999.9 / 3000.0 (Default : 0)
User - Linearisation LINEARISATION>> Disable	Disable Enable (Default : Disable)
Total Break - Points BREAK POINTS>> 2	2 to 32 (Default : 2)

ALARM CONFIGURATION	
Parameters	Settings (Default Value)
Alarms Per Channel ALARMS / CHAN >> 4	1 to 4 (Default : 4)
Relay-1 Logic RELAY-1 LOGIC >> Normal	Normal Reverse (Default : Normal)
Relay-2 Logic RELAY-2 LOGIC >> Normal	Normal Reverse (Default : Normal)

* For UniLog Plus Only

TABLE- 1	
Option	Description
°C	Degree Centigrade
°F	Degree Fahrenheit
(none)	No Unit (Blank)
°K	Degree Kelvin
EU	Engineering Units
%	Percentage
Pa	Pascals
Mpa	Mpascals
kPa	Kpascals
bar	Bar
mbar	Milli bar
psi	PSI
kg/sq.cm	kg/cm ²
mmH2O	mm water gauge
inH2O	Inches water gauge
mmHg	mm mercury
Torr	Torr
litre/hr	Litres per hour
litre/min	Litres per minute
%RH	% Relative Humidity
%O2	% Oxygen
%CO2	% Carbon di-oxide
%CP	% Carbon Potential
V	Volts
A	Amps
mA	Milli Amps
mV	Milli Volts
ohm	Ohms
ppm	Parts per million
rpm	Revolutions per minute
mSec	Milli seconds
Sec	Seconds
min	Minutes
hrs	Hours
PH	PH
%PH	%PH
miles/hr	Miles per hour
mg	Milli grams
g	Grams
kg	Kilo grams

RECORDER CONFIGURATION	
Parameters	Settings (Default Value)
Normal Recording Interval NORMAL INTERVAL>> 0:00:30	0:00:00 (H:MM:SS) to 2:30:00 (H:MM:SS) (Default : 0:00:30)
Zoom Recording Interval ZOOM INTERVAL>> 0:00:01	0:00:00 (H:MM:SS) to 2:30:00 (H:MM:SS) (Default : 0:00:01)
Record Generation on Alarm Status Toggle ALARM TOGGLE REC>> Disable	Disable Enable (Default : Enable)
Select Recording Mode RECORDING MODE>> Continuous	Continuous Batch (Default : Continuous)
Time Interval for Batch Recording (for Batch mode only) BATCH TIME>> 1.00	0:01 (HH:MM) to 250:00 (HH:MM) (Default : 1:00)

RTC SETTING	
Parameters	Settings
Set Clock Time (HH:MM) TIME (HH:MM)>> 15:53	0.0 to 23:59
Set Calendar Date DATE>> 23	1 to 31
Set Calendar Month MONTH>> 11	1 to 12
Set Calendar Year YEAR>> 2011	2000 to 2099

UTILITIES	
Parameters	Settings
Master Lock Enable/Disable LOCK>> No	No Yes
UNLOCK>> No	No Yes

Note: All the other Parameters are under SUPERVISORY CONFIGURATION

ALARM SETTING	
Parameters	Settings (Default Value)
Channel Name for Alarm Settings SELECT CHANNEL>> Channel-1	User defined or default names for channel-1 to channel-8 / 16 (Default : NA)
Select Alarm SELECT ALARM>> AL1	AL1, AL2, AL3, AL4 (The actual available options depends on the numbers of Alarms set per channel on Alarm configuration page)
Alarm Type AL1 TYPE>> None	None Process Low Process High (Default : None)
Alarm Setpoint AL1 SETPOINT>> 0	Min. to Max. of selected input type range (Default : 0)
Alarm Hysteresis AL1 HYSTERESIS>> 2	1 to 3000 or 0.1 to 3000.0 (Default : 2 or 2.0)
Alarm Inhibit AL1 INHIBIT>> Yes	No Yes (Default : No)

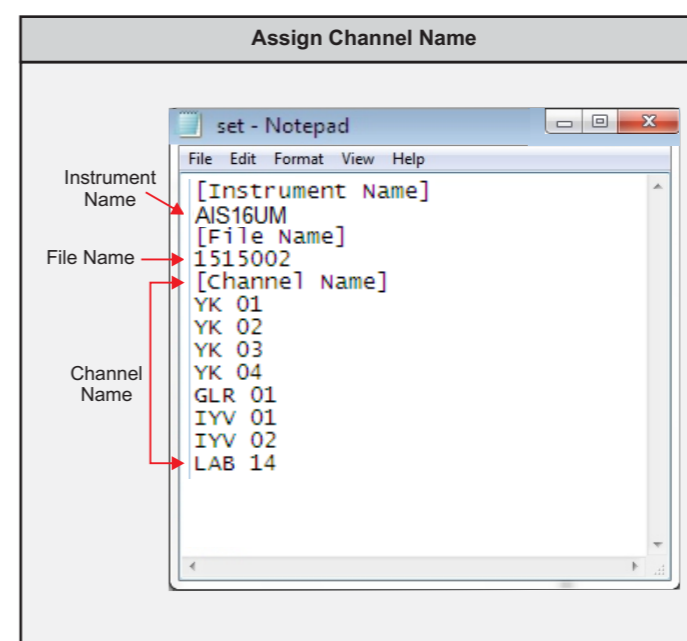

FRONT PANEL LAYOUT

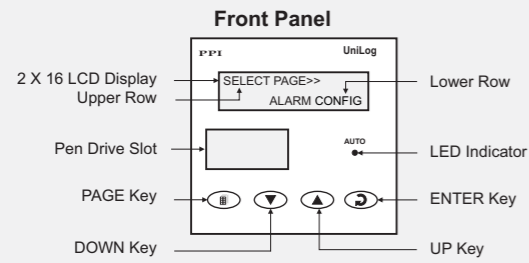

Keys Operation

Symbol	Key	Function
	PAGE	Press to enter or exit set-up mode.
	DOWN	Press to decrease the parameter value. Pressing once decreases the value by one count; holding pressed speeds up the change.
	UP	Press to increase the parameter value. Pressing once increases the value by one count; holding pressed speeds up the change.
	ENTER	Press to store the set parameter value and to scroll to the next parameter on the PAGE.

PV Error Indications

Error Message	Cause
Over Range	Process Value above Max. Range
Under Range	Process Value below Min. Range
Sensor Open	Thermocouple / RTD broken
Com. Fail	Communication Link with CIM broken

ELECTRICAL CONNECTIONS

USER INTERFACE MODULE (UIM)

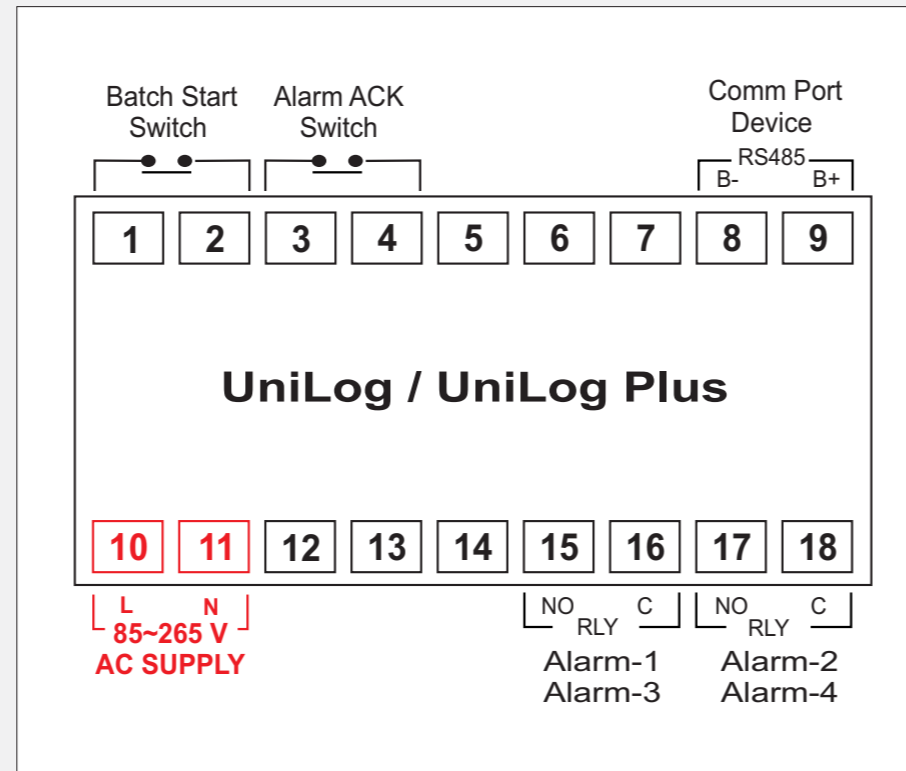

COMMUNICATION PORT FOR INTERFACING WITH AIS(S)

Applicable only for **UNILOG PLUS**

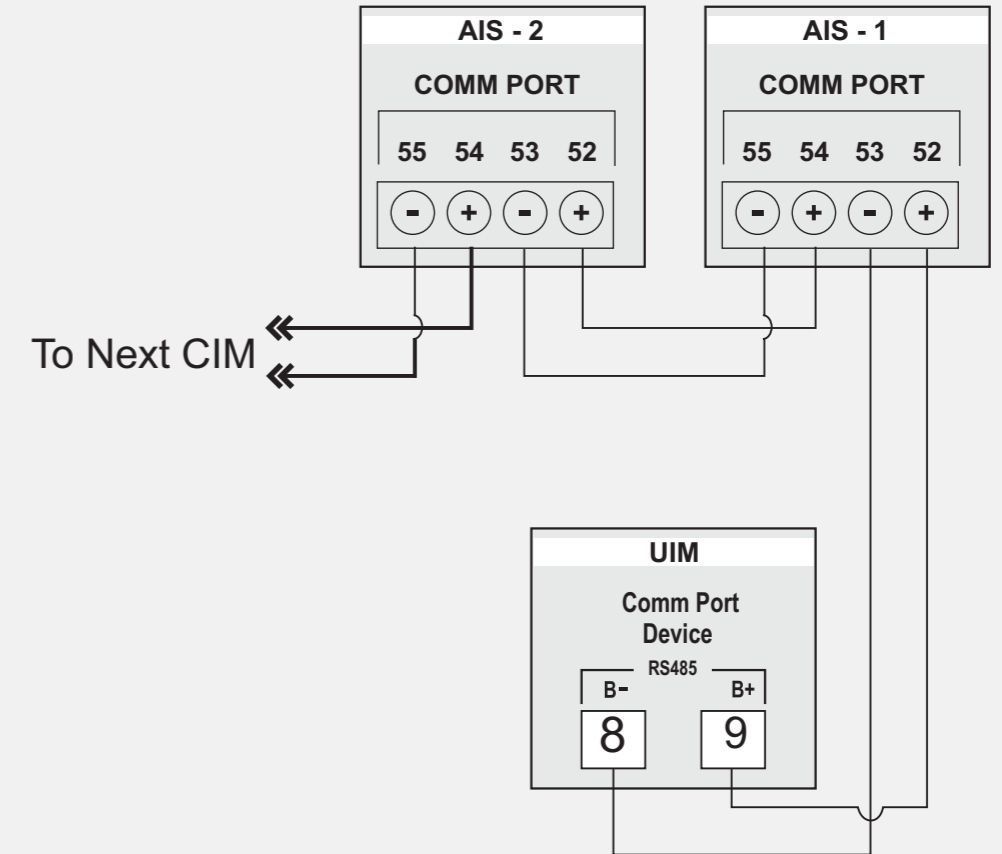

ANALOG INPUT MODULE CONNECTIONS

AIS-8UM

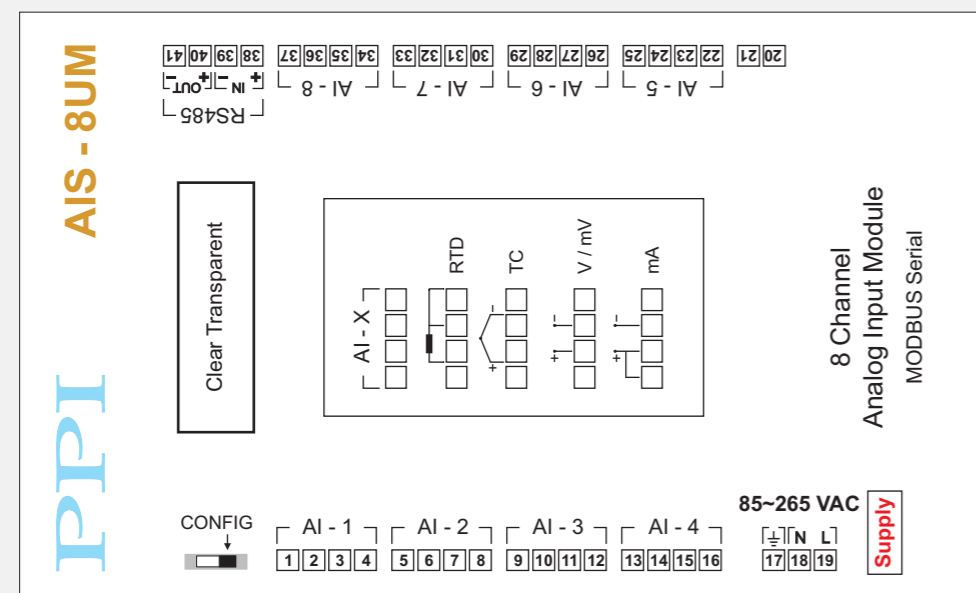

AIS-16UM

