

neuro 102Plus



PPI

The Perfection Experts

Advanced
Universal Single Loop
Process Controller



User Manual

CONTENTS

1. FRONT PANEL LAYOUT	1
2. BASIC OPERATION	3
3. SET-UP MODE : ACCESS AND OPERATION	8
4. CONTROL PARAMETERS : PAGE-10	10
5. ALARM RETRANSMISSION (RECORDER) PARAMETERS : PAGE-11	12
6. INPUT/OUTPUT CONFIGURATION PARAMETERS : PAGE-12	14
7. SUPERVISORY PARAMETERS : PAGE-13	17
8. PROFILE PARAMETERS : PAGE-16, PAGE-14, PAGE-1	19
9. OP1, OP2 & OP3 FUNCTION PARAMETERS : PAGE-15	23
10. HARDWARE ASSEMBLY & CONFIGURATIONS	26
11. MECHANICAL INSTALLATION	31
12. ELECTRICAL CONNECTIONS	33
APPENDIX-A : DC LINEAR SIGNAL INTERFACE	37

Section 1 FRONT PANEL LAYOUT

The controller front panel comprises of Digital Readouts, LED Indicators and Push Button Keys as shown in Figure 1.1 below.

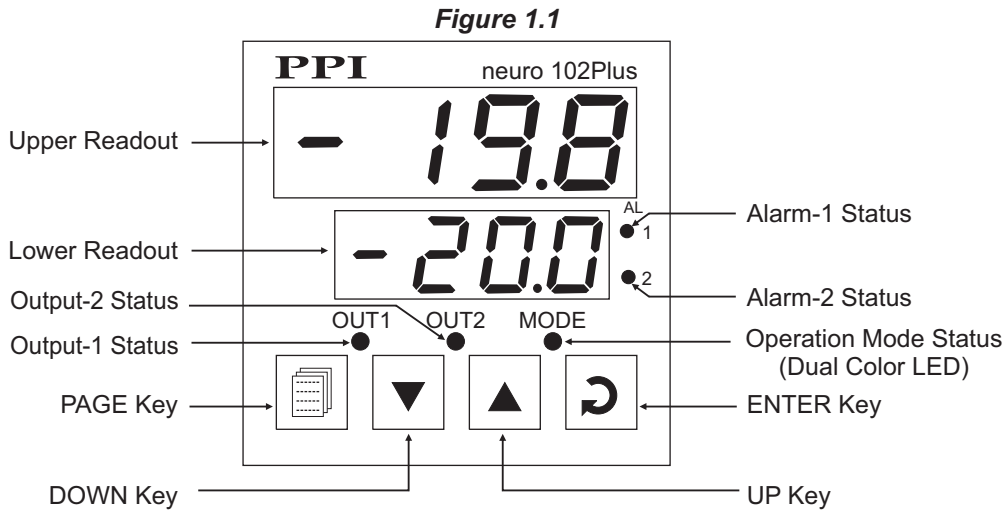

READOUTS

The Upper Readout is a 4 digit, 7-segment bright red LED display and usually displays the PV (Process Value). In Set-up Mode, the Upper Readout displays parameter values/options.

The Lower Readout is a 4 digit, 7-segment bright green LED display and usually displays Setpoint Value or % Output Power. In Set-up Mode, the Lower Readout displays parameter names (prompts).

INDICATORS

The front panel indicators are LED's that show the status related to control, alarm and operation mode. Refer Table 1.1 below for details.

Table 1.1





Indicator		Status
AL	1 (Red LED)	Flashes while Alarm-1 is active
	2 (Red LED)	Flashes while Alarm-2 is active
OUT1 (Red LED)		Indicates Output-1 ON/OFF status if the control output is Relay / SSR Non-Functional (OFF) if the control output is DC Linear (mA/ V)
OUT2 (Red LED)		Indicates Output-2 ON/OFF status if the control output is Relay / SSR Non-Functional (OFF) if the control output is DC Linear (mA/ V)
MODE (Dual Colour LED : Red & Green)		<ul style="list-style-type: none"> • Remains OFF if controller is in Auto Mode with Main Control Setpoint (SP) active • Glows Red if controller is in Manual Mode • * Flashes Green while the Ramp/Soak Profile is in progress & glows steady Green if Profile is in HOLD State • * Glows Green if Auxiliary Setpoint is Active

* The 'Ramp/Soak Profile' and 'Auxiliary Setpoint' options are mutually exclusive.

KEYS

There are four tactile keys provided on the front panel for configuring the controller, setting-up the parameter values and selecting Operation Modes. Refer Table 1.2 for detailed key operations.

Table 1.2

Symbol	Key	Function
	PAGE	Press to enter or exit set-up mode.
	DOWN	Press to decrease the parameter value. Pressing once decreases the value by one count; keeping pressed speeds up the change.
	UP	Press to increase the parameter value. Pressing once increases the value by one count; keeping pressed speeds up the change.
	ENTER	Press to store the set parameter value and to scroll to the next parameter on the PAGE.



Section 2 BASIC OPERATION

POWER-UP

Upon power-up, all displays and indicators are lit on for approximately 3 seconds. This is followed by the indication of the controller model name `n.102` on the Upper Readout and the firmware version (e.g. `0101`) on the Lower Readout, for approximately 1 second.

MAIN DISPLAY MODE

After the Power-up display sequence, the Upper Readout starts showing the measured PV (Process Value) and the Lower Readout displays the Setpoint Value. This is the MAIN Display Mode that shall be used most often.

% Output Power Indication

In PID control mode, the Lower Readout can be toggled using ENTER key to indicate either % output power or setpoint value (SP). The output power is indicated with the left most digit showing 'P', 'H' or 'C' depending upon uni-directional (Heat or Cool) or bi-directional (Heat and Cool) control mode. Refer Figure 2.1 below.

Figure 2.1

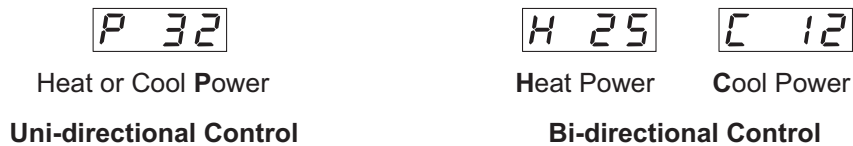

Adjusting SP (Control Setpoint)

If permitted at Supervisory Level, the SP value can be directly adjusted on the Lower Readout in the MAIN Display Mode. While the Lower Readout shows the control setpoint, step through the following sequence for adjusting the SP value :

1. Press and release UP or DOWN key once. The Lower Readout starts flashing.
2. Use UP/ DOWN keys to adjust the SP value.
3. Press and release ENTER key. The Lower Readout stops flashing and the new set value is registered and stored.

Tune Mode Indication (PID Control)

The Lower Readout flashes `TUNE` while the controller is Tuning. Do not disturb the process or alter any parameter values while Tuning is in progress. The "Tune" message automatically disappears upon completion of Tuning procedure.

Profile Mode Indications

(Applicable if controller is supplied with Ramp / Soak Profile option)

While a Profile Cycle is in progress, the front panel indicator 'MODE' flashes or glows steady with Green color. The steady glowing indicates that though the profile is active, it is currently in HOLD state. Also, the Lower Readout shows the Profile Setpoint instead of the control setpoint (SP). The % Output Power (if PID Control) can be viewed by toggling the Lower Readout using ENTER key.

The Lower Readout also facilitates viewing the information about the current profile segment viz.; the Segment Number, Segment Type (ramp / soak) and the Target Set-point (if current segment is ramp) or the Balance Time (if current segment is soak).

Upon keeping the UP Key pressed, the Lower Readout shows the Segment Type and Segment Number as shown in Figure 2.2 (a) & 2.2 (b).

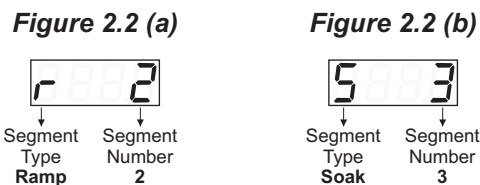

Upon keeping the DOWN Key pressed, the Lower Readout shows the Target Set-point (if current segment is ramp) or the Balance Time (if current segment is soak) as shown in Figure 2.3 (a) & 2.3 (b).

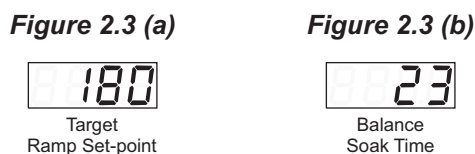

Note :

If Profile Cycle is in progress; the controller is always in Auto Mode. That is, Manual Mode selection is suppressed.

Auxiliary Set-point Mode Indication

(Applicable if controller is supplied with Auxiliary Set-point option)

The Controller is supplied with 2 rear panel terminals for connecting remote switch (potential-free contacts) to toggle between Main Control Set-point (SP) & Auxiliary Control Set-point.

The "Open" & "Close" switch positions activate Main Control Set-point (SP) & Auxiliary Control Set-point, respectively.

The front panel indicator 'MODE' glows steady with Green color if Auxiliary Control Set-point is active.

PV Error Indications

The PV Error Type is flashed on the Upper Readout. For different Error Types and the Causes, refer Table 2.1 below.

Table 2.1

Upper Readout	Error Type	Cause
Or	Over-range	PV above Max. Range
Ur	Under-range	PV below Min. Range
OPE n	Sensor Open	Thermocouple / RTD broken

CONTROL / ALARM STATUS UNDER PV ERROR CONDITIONS

- The tuning, if in progress, is aborted.
- The Profile Cycle, if in progress, enters in HOLD state.
- While in *Over-range* or *Under-range* error condition, all the control outputs are switched off. However, under *Sensor Open* error, the PID control output power is maintained at the value set for the parameter "Sensor Break Output Power" on PAGE-12.
- For Alarm activation, the *Under-range* condition is treated as minimum PV, whereas the *Over-range* and *Sensor Open* conditions are treated as maximum PV. Thus, Process High, positive Deviation Band and Window Band alarms activate under *Over-range/Sensor Open* error. Similarly, Process Low, negative Deviation Band and Window Band alarms activate during *Under-range* error.

MANUAL MODE OPERATION

This operation mode is available only if the control action is PID and if the manual mode operation is permitted at supervisory level. In this mode, the controller operates in Open Loop mode wherein the % Output Power is manually adjusted by the operator. This mode is often used for process start-up to make sure that the process equilibrium is achieved before the control is transferred for subsequent automatic (closed loop) control. The controller ensures a *bumpless* Auto / Manual transfer.

The manual mode can be activated or de-activated using ENTER key. While in manual mode, the Upper Readout shows PV and the Lower Readout shows % Power that can be adjusted using UP/DOWN keys.

Follow the steps below to enter (Activate) into Manual Mode and to revert to (De-activate) Automatic Mode.

1. Hold ENTER key pressed for approximately 2 seconds until front panel indicator MODE glows steady with Red color.
2. Release Enter key. The controller is now placed in Manual mode. The Upper Readout displays the PV and the Lower Readout displays the %Output Power.
3. Adjust the Output Power using the UP and DOWN keys. The Output Power is adjustable between the set Power Low and Power High limits.

To de-activate the Manual mode; Hold the ENTER key pressed for approximately 2 seconds until the front panel indicator MODE turns off. The controller now enters into Auto control mode with the first power same as that was adjusted last while in Manual mode.

Notes:

1. *The Controller can not be placed in Manual mode while a Profile Cycle is in progress. If the controller is in manual mode and if profile start command is issued, the controller reverts to Auto Mode and initiates profile.*
2. *The Manual mode Activation / De-activation is suppressed while the Tuning is in progress. However, the Tuning procedure can be activated regardless of whether the controller is in Auto or Manual control mode.*
3. *While the Controller is in Manual Mode, Standby Mode (explained later in this section) can not be entered and vice-a-versa.*
4. *If the power fails while the Manual Control Mode is active; upon resumption of power the controller continues to remain in Manual control mode with the last user set power.*

STANDBY MODE

This mode, allows the operator to put the controller in '*indication-only*' mode wherein all the output control signals as well as Alarm Relays are forced OFF. This may be desired prior to the start of a new process batch.

If enabled at supervisory level, the standby mode can be activated or de-activated by setting the parameter 'Standby' to Yes or No, respectively. The standby parameter is available on Operator PAGE-0.

Notes:

1. *The Standby mode and Tuning operation are mutually exclusive. If Standby mode is activated while the controller is tuning, the controller aborts tuning operation and enters Standby mode.*
2. *If the Power Supply to the controller is switched-off or a Power-failure occurs while the controller is operating in Standby mode; upon resumption of power, the controller continues to operate in Standby mode.*

OPERATOR PAGE AND PARAMETERS

The controller provides a separate page that contains parameters that require frequent settings by the operator. The page is called *Operator Page* and the parameters are called *Operator Parameters*. The availability of operator parameters is controlled at supervisory level and the parameter settings is not locked by the Master Lock.

Accessing Operator Page & Adjusting Parameters

Step through the following sequence to open the operator page and to adjust the operator parameter values.

1. Press and release PAGE key. The Lower Readout shows **PAGE** (PAGE) and Upper Readout shows **0** (0).
2. Press ENTER key. The Lower Readout shows prompt for the first available operator parameter and the Upper Readout shows value for the parameter.
3. Use UP / DOWN keys to adjust the value and then press ENTER key to store the set value and scroll to next parameter.

The controller automatically reverts to MAIN Display Mode upon scrolling through the last operator parameter. Alternatively, use PAGE key to return to MAIN Display Mode.

The operator parameters are described in Table 2.2. Note that the parameters presented on operator page depend upon the functions selected/enabled and supervisory level permissions.

Table 2.2

Parameter Description	Settings
ACTIVATE / DE-ACTIVATE STANDBY MODE Stby This parameter is available and applicable only if Standby mode is enabled at supervisory level. Set the parameter value to 'Yes' or 'No' for entering and exiting the Standby mode, respectively.	no No YES Yes (Default : No)
CONTROL SETPOINT SP This is the Main Setpoint value that the controller respects for the control purpose. This value is not applicable if running a profile or if the controller is tuning or in standby mode.	Setpoint Low Limit to Setpoint High Limit (Default : -1999)
ALARM-1 SETPOINT A1SP The Process High or Process Low limit for Alarm-1.	Min. to Max. Range specified for the selected Input Type (Default : Min or Max Range)
ALARM-1 DEVIATION BAND A1dE The Alarm setpoint for Alarm-1 if the Alarm Type is the Deviation Band value for Alarm-1.	For DC mA/mV/V : -1999 to 9999 counts For Thermocouples/RTD : -999 to 999 or -1.999 to 999.9 (Default : 0)
ALARM-1 WINDOW BAND A1bA The Alarm setpoint for Alarm-1 if the Alarm Type is the Window Band value for Alarm-1.	For DC mA/mV/V : 3 to 9999 counts For Thermocouples/RTD : 3 to 999 or 0.3 to 999.9 (Default : 0)
ALARM-2 SETPOINT A2SP ALARM-2 DEVIATION BAND A2dE ALARM-2 WINDOW BAND A2bA Same as that described for Alarm-1 above but applied to Alarm-2.	Same as that for Alarm-1 above but applied to Alarm-2.

Parameter Description	Settings
<p>AUXILIARY CONTROL SETPOINT AUSP</p> <p><i>(Available only if the Controller is supplied with Auxiliary Set-point option)</i></p> <p>The alternate control set-point that the controller respects for control purpose when selected through remote input terminals.</p>	<p>Setpoint Low Limit to Setpoint High limit (Default : -1999)</p>



Section 3

SET-UP MODE : ACCESS AND OPERATION

The various parameters are arranged in different groups, called PAGES, depending upon the functions they represent. Each group is assigned a unique numeric value, called PAGE NUMBER, for its access.

The parameters are always presented in a fixed format: The Lower Readout displays the parameter prompt (Identification Name) and the Upper Readout displays the set value. The parameters appear in the same sequence as listed in their respective sections.

SET-UP MODE

The Set-up Mode allows the user to view and modify the parameter values. Follow the steps below for setting the parameter values:

1. Press and release PAGE key. The Lower Readout shows PAGE and the Upper Readout shows page number 0. Refer Figure 3.1.
2. Use UP / DOWN keys to set the desired PAGE NUMBER.
3. Press and release ENTER key. The Lower Readout shows the prompt for the first parameter listed in the set PAGE NUMBER and the Upper Readout shows its current value. If the entered PAGE NUMBER is invalid (contains no parameter list or any associated function), the controller reverts to the MAIN Display Mode.
4. Press and release the ENTER key until the prompt for the required parameter appears on the Lower Readout. (The last parameter in the list rolls back to the first parameter).
5. Use UP / DOWN keys to adjust the parameter value. (The display flashes if UP key is pressed after reaching the maximum value or DOWN key is pressed after reaching the minimum value).
6. Press and release the ENTER key. The new value gets stored in the controller's non-volatile memory and the next parameter in the list is displayed.

The Figure 3.1 illustrates the example of altering the value for the parameter 'Control Action' from On-Off to PID.

Figure 3.1

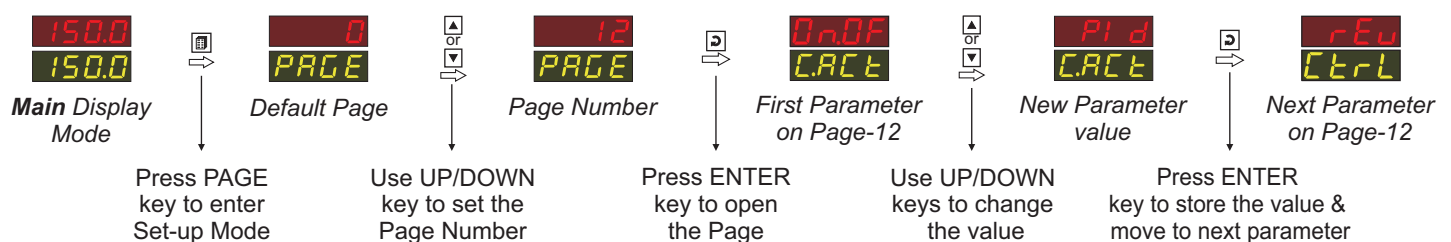

Notes

1. Each page contains a fixed list of parameters that are presented in a pre-determined sequence. Note, however, that availability of a few parameters, called Conditional Parameters, depend upon the settings for some other parameters. For example, the parameter 'Control Hysteresis' for Output-1 is available only if, the set value for the parameter 'Control Action' is 'On-Off'.
2. To exit the set-up mode and return to the MAIN Display Mode, press and release PAGE key.
3. If no key is pressed for approximately 30 seconds, the set-up mode times out and reverts to the MAIN Display Mode.

MASTER LOCKING

The controller facilitates locking all the PAGES (except Operator PAGE) by applying Master Lock Code. Under Locking, the parameters are available for *view only* and cannot be adjusted. The Master Lock, however, does not lock the operator parameters. This feature allows protecting the rather less frequently used parameters against any inadvertent changes while making the frequently used operator parameters still available for editing.

For enabling / disabling the Lock, step through the following sequence:

Locking

1. Press and release PAGE key while the controller is in the MAIN Display Mode. The Lower Readout shows PAGE and the Upper Readout shows 0.
2. Use UP / DOWN keys to set the Page Number to 123 on the Upper Readout.
3. Press and release ENTER key. The controller returns to the MAIN Display Mode with the Lock enabled.

The Figure 3.2 below illustrates the Locking procedure.

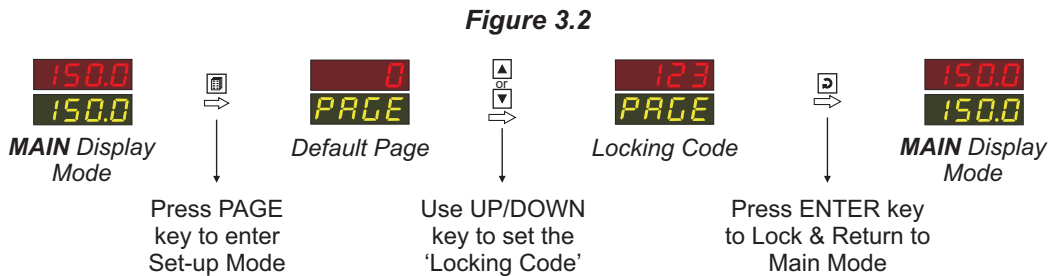

Un-Locking

Repeat the Locking procedure twice for unlocking.



Section 4
CONTROL PARAMETERS : PAGE-10

Refer Table 4.1 for the parameter descriptions and settings.

Table 4.1

Parameter Description	Settings (Default Value)
PROPORTIONAL BAND Pb <i>(Available for PID Control only)</i> Sets proportional gain (% power per unit error). Defined in same units and resolution as that for PV.	1 to 9999 counts (Default : 500)
INTEGRAL TIME It <i>(Available for PID Control only)</i> Sets integral time constant in seconds. Setting the value to 0, cuts-off integral action.	0 to 3600 Seconds (Default : 100 sec.)
DERIVATIVE TIME dt <i>(Available for PID Control only)</i> Sets derivative time constant in seconds. Setting the value to 0, cuts-off derivative action.	0 to 600 Seconds (Default : 16 sec.)
CYCLE TIME Ct <i>(Available for PID Control only)</i> Sets the total 'On + Off' time in seconds for time modulating power output through Output-1 Relay / SSR.	0.5 to 100.0 Seconds (in steps of 0.5 secs.) (Default : 10.0 sec.)
RELATIVE COOL GAIN rELC <i>(Available for PID Control with bi-directional, that is, Heat-Cool mode)</i> Sets the ratio of cooling power to the heating power.	0.1 to 10.0 (Default : 1.0)
COOL CYCLE TIME CCT <i>(Available for PID Control with bi-directional, that is, Heat-Cool mode)</i> Sets the On + Off cycle time in seconds for time modulating power output through Output-2 Relay / SSR.	0.5 to 100.0 Seconds (in steps of 0.5 secs.) (Default : 10.0 sec.)
HYSTERESIS HYST <i>(Available for On-Off or Pulsed On-Off Control only)</i> Sets differential (dead) band between On-Off switching for Output-1. Defined in same units and resolution as that for PV.	1 to 9999 counts (Default : 2)
PULSE TIME PLT <i>(Available for Pulsed On-Off Control only)</i> Sets the total 'On + Off' pulse time in seconds for Output-1 Relay / SSR output.	Pulse ON Time to 120.0 Seconds (Default : 2.0 sec.)

Parameter Description	Settings (Default Value)
PULSE-ON TIME [On.t] <i>(Available for Pulsed On-Off Control only)</i> Sets the ON pulse time in seconds for Output-1 Relay / SSR output.	0.1 to Value set for Pulse Time (Default : 1.0)
COOL HYSTERESIS [CHYS] <i>(Available for On-Off or Pulsed On-Off Control with bi-directional mode)</i> Sets differential (dead) band between On-Off switching for Output-2. Defined in same units and resolution as that for PV.	1 to 9999 counts (Default : 2)
COOL PULSE TIME [CPLT] <i>(Available for Pulsed On-Off Control with bi-directional mode)</i> Sets the total 'On + Off' pulse time in seconds for Output-2 Relay / SSR output.	Cool ON Time to 120.0 Seconds (Default : 2.0)
COOL PULSE-ON TIME [COnt] <i>(Available for Pulsed On-Off Control with bi-directional mode)</i> Sets the ON pulse time in seconds for Output-2 Relay / SSR output.	0.1 to Value set for Cool Pulse Time (Default : 1.0)
HEAT POWER LOW [PL] <i>(Available for PID Control only)</i> Sets the minimum % output power limit for Output-1.	0 to Heat Power High (Default : 0)
HEAT POWER HIGH [PH] <i>(Available for PID Control only)</i> Sets the maximum % output power limit for Output-1 .	Heat Power Low to 100 (Default : 100)
COOL POWER LOW [CPL] <i>(Available for PID Control with bi-directional, that is, Heat-Cool mode)</i> Sets the minimum % output power limit for Output-2.	0 to Cool Power High (Default : 0)
COOL POWER HIGH [CPH] <i>(Available for PID Control with bi-directional, that is, Heat-Cool mode)</i> Sets the maximum % output power limit for Output-2.	Cool Power Low to 100 (Default : 100)

Section 5

ALARM AND RETRANSMISSION (RECORDER) PARAMETERS : PAGE 11

Refer Table 5.1 for parameter description & settings.

Table 5.1

Parameter Description	Settings (Default Value)
ALARM-1 TYPE AL_1 Selects the Alarm-1 activation type. Selecting 'None' disables the alarm and suppresses all the related parameters for Alarm-1.	<div style="display: flex; flex-direction: column; align-items: flex-start;"> <div style="display: flex; align-items: center; margin-bottom: 2px;"> <div style="border: 1px solid black; padding: 2px; margin-right: 5px;">nonE</div> None </div> <div style="display: flex; align-items: center; margin-bottom: 2px;"> <div style="border: 1px solid black; padding: 2px; margin-right: 5px;">P_Lo</div> Process Low </div> <div style="display: flex; align-items: center; margin-bottom: 2px;"> <div style="border: 1px solid black; padding: 2px; margin-right: 5px;">P_hI</div> Process High </div> <div style="display: flex; align-items: center; margin-bottom: 2px;"> <div style="border: 1px solid black; padding: 2px; margin-right: 5px;">dE</div> Deviation Band </div> <div style="display: flex; align-items: center;"> <div style="border: 1px solid black; padding: 2px; margin-right: 5px;">bAnd</div> Window Band </div> </div> <p style="text-align: center;">(Default : None)</p>
ALARM-1 SETPOINT A 1SP <i>(Available for Process High or Process Low Alarm-1 Type)</i> Sets Alarm limit independent of control setpoint for Alarm-1 activation. Defined in same units and resolution as that for PV.	Min. to Max. Range specified for the selected Input Type (Default : Min or Max Range)
ALARM-1 DEVIATION BAND A 1dE <i>(Available for Deviation Band Alarm-1 Type)</i> Sets positive or negative deviation (offset) limit from control setpoint for High or Low Alarm-1 activation, respectively. Defined in same units and resolution as that for PV.	For DC mA/mV/V : -1999 to 9999 counts For Thermocouples/RTD : -999 to 999 or -1.999 to 999.9 (Default : 5)
ALARM-1 WINDOW BAND A 1bA <i>(Available for Window Band Alarm-1 Type)</i> Sets symmetrical positive and negative deviation (offset) limits around control setpoint for both High and Low Alarm-1 activation. Defined in same units and resolution as that for PV.	For DC mA/mV/V : 3 to 9999 counts For Thermocouples/RTD : 3 to 999 or 0.3 to 999.9 (Default : 5)
ALARM-1 HYSTERESIS A 1HY Sets differential (dead) band between Alarm-1 ON and OFF switching states. Units and resolution are same as that for PV.	For DC mA/mV/V : 1 to 9999 counts For Thermocouples/RTD : 1 to 999 or 0.1 to 999.9 (Default : 2)
ALARM-1 INHIBIT A 1h Setting to 'Yes' suppresses Alarm-1 activation upon power-up or process start-up.	<div style="display: flex; flex-direction: column; align-items: flex-start;"> <div style="display: flex; align-items: center; margin-bottom: 2px;"> <div style="border: 1px solid black; padding: 2px; margin-right: 5px;">no</div> No </div> <div style="display: flex; align-items: center;"> <div style="border: 1px solid black; padding: 2px; margin-right: 5px;">YES</div> Yes </div> </div> <p style="text-align: center;">(Default : No)</p>

Parameter Description	Settings (Default Value)
<p>ALARM-2 TYPE AL_2</p> <p>ALARM-2 SETPOINT A2SP</p> <p>ALARM-2 DEVIATION BAND A2dE</p> <p>ALARM-2 WINDOW BAND A2bA</p> <p>ALARM-2 HYSTERESIS A2HY</p> <p>ALARM-2 INHIBIT A2, h</p> <p>Same as that described for Alarm-1 above but applied to Alarm-2.</p>	<p>Same as that for Alarm-1 above but applied to Alarm-2.</p>
<p>PV/SP SELECTION FOR RETRANSMISSION trnS</p> <p><i>(Available if Output-3 function is recorder)</i> Selects either Process Value (PV) or Control Setpoint (SP) for retransmission (recording).</p>	<p>PV Process Value</p> <p>SP Setpoint (Default : Process Value)</p>
<p>RECORDER (RETRANSMISSION) LOW rECL</p> <p><i>(Available if Output-3 function is recorder)</i> Sets the minimum value (PV or SP) that shall correspond to the minimum recorder output signal level (0 mA or 4 mA or 0 V).</p>	<p>Min. to Max. Range Specified for the Selected Input Type (Default : -199)</p>
<p>RECORDER (RETRANSMISSION) HIGH rECH</p> <p><i>(Available if Output-3 function is recorder)</i> Sets the maximum value (PV or SP) that shall correspond to the maximum recorder output signal level (20 mA or 5 V or 10 V).</p>	<p>Min. to Max. Range Specified for the Selected Input Type (Default : 1376)</p>

Section 6

INPUT/OUTPUT CONFIGURATION PARAMETERS : PAGE-12















Refer Table 6.1 for parameter description & settings.

Table 6.1

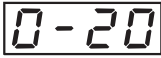
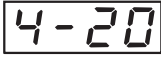
Parameter Description	Settings (Default Value)																											
CONTROL ACTION CAct Select appropriate Control Algorithm suited for process requirement.	OnOff On-Off PULS Pulse PId PID (Default : PID)																											
CONTROL LOGIC Ctrl Select Reverse (<i>heat</i> logic) or Direct (<i>cool</i> logic).	rEu Reverse dir Direct (Default : Reverse)																											
SETPOINT LOW LIMIT SPLo Set minimum permissible value for control setpoint.	Min. Range to Setpoint High for the selected Input Type (Default : -199)																											
SETPOINT HIGH LIMIT SPHi Set maximum permissible value for control setpoint.	Setpoint Low to Max. Range for the selected Input Type (Default : 1376)																											
SENSOR BREAK OUTPUT POWER% SbOP <i>(Available for PID control only)</i> In case of Thermocouple / RTD broken or disconnected, the controller outputs this power value under open loop condition.	0 to 100 % (Default : 0 %)																											
INPUT TYPE InPt Select Input type in accordance with the type of Thermocouple or RTD or Sensor / Transducer Output (mA/mV/V) connected for process value measurement.	Refer Table 6.2 (Default : Type K)																											
PV UNITS Unit <i>(Available for Thermocouple / RTD Inputs)</i> Selects temperature measurement units in °C or °F.	°C °C °F °F (Default : °C)																											
SIGNAL LOW SLo <i>(Available for DC linear mV/V/mA Inputs only)</i> The transmitter output signal value corresponding to PV RANGE LOW parameter value. Refer <i>Appendix-A : DC Linear Signal Interface</i> for details.	<table border="1"> <thead> <tr> <th>Input Type</th> <th>Settings</th> <th>Default</th> </tr> </thead> <tbody> <tr> <td>0 to 20 mA</td> <td>0.00 to Signal High</td> <td>0.00</td> </tr> <tr> <td>4 to 20 mA</td> <td>4.00 to Signal High</td> <td>4.00</td> </tr> <tr> <td>0 to 80 mV</td> <td>0.00 to Signal High</td> <td>0.00</td> </tr> <tr> <td>Reserved</td> <td>0.0 to Signal High</td> <td>0.0</td> </tr> <tr> <td>0 to 1.25 V</td> <td>0.000 to Signal High</td> <td>0.000</td> </tr> <tr> <td>0 to 5 V</td> <td>0.000 to Signal High</td> <td>0.000</td> </tr> <tr> <td>0 to 10 V</td> <td>0.00 to Signal High</td> <td>0.00</td> </tr> <tr> <td>1 to 5 V</td> <td>1.000 to Signal High</td> <td>1.000</td> </tr> </tbody> </table>	Input Type	Settings	Default	0 to 20 mA	0.00 to Signal High	0.00	4 to 20 mA	4.00 to Signal High	4.00	0 to 80 mV	0.00 to Signal High	0.00	Reserved	0.0 to Signal High	0.0	0 to 1.25 V	0.000 to Signal High	0.000	0 to 5 V	0.000 to Signal High	0.000	0 to 10 V	0.00 to Signal High	0.00	1 to 5 V	1.000 to Signal High	1.000
Input Type	Settings	Default																										
0 to 20 mA	0.00 to Signal High	0.00																										
4 to 20 mA	4.00 to Signal High	4.00																										
0 to 80 mV	0.00 to Signal High	0.00																										
Reserved	0.0 to Signal High	0.0																										
0 to 1.25 V	0.000 to Signal High	0.000																										
0 to 5 V	0.000 to Signal High	0.000																										
0 to 10 V	0.00 to Signal High	0.00																										
1 to 5 V	1.000 to Signal High	1.000																										

Parameter Description	Settings (Default Value)																											
<p>SIGNAL HIGH S.H.</p> <p><i>(Available for DC linear mV/V/mA Inputs only)</i> The transmitter output signal value corresponding to PV RANGE HIGH parameter value. Refer <i>Appendix-A : DC Linear Signal Interface</i> for details.</p>	<table border="1"> <thead> <tr> <th>Input Type</th> <th>Settings</th> <th>Default</th> </tr> </thead> <tbody> <tr> <td>0 to 20 mA</td> <td>Signal Low to 20.00</td> <td>20.00</td> </tr> <tr> <td>4 to 20 mA</td> <td>Signal Low to 20.00</td> <td>20.00</td> </tr> <tr> <td>0 to 80 mV</td> <td>Signal Low to 80.00</td> <td>80.00</td> </tr> <tr> <td>Reserved</td> <td>Signal Low to 80.00</td> <td>80.00</td> </tr> <tr> <td>0 to 1.25 V</td> <td>Signal Low to 1.250</td> <td>1.250</td> </tr> <tr> <td>0 to 5 V</td> <td>Signal Low to 5.000</td> <td>5.000</td> </tr> <tr> <td>0 to 10 V</td> <td>Signal Low to 10.00</td> <td>10.00</td> </tr> <tr> <td>1 to 5 V</td> <td>Signal Low to 5.000</td> <td>5.000</td> </tr> </tbody> </table>	Input Type	Settings	Default	0 to 20 mA	Signal Low to 20.00	20.00	4 to 20 mA	Signal Low to 20.00	20.00	0 to 80 mV	Signal Low to 80.00	80.00	Reserved	Signal Low to 80.00	80.00	0 to 1.25 V	Signal Low to 1.250	1.250	0 to 5 V	Signal Low to 5.000	5.000	0 to 10 V	Signal Low to 10.00	10.00	1 to 5 V	Signal Low to 5.000	5.000
Input Type	Settings	Default																										
0 to 20 mA	Signal Low to 20.00	20.00																										
4 to 20 mA	Signal Low to 20.00	20.00																										
0 to 80 mV	Signal Low to 80.00	80.00																										
Reserved	Signal Low to 80.00	80.00																										
0 to 1.25 V	Signal Low to 1.250	1.250																										
0 to 5 V	Signal Low to 5.000	5.000																										
0 to 10 V	Signal Low to 10.00	10.00																										
1 to 5 V	Signal Low to 5.000	5.000																										
<p>PV RESOLUTION r5Ln</p> <p><i>(Available for DC linear mV/V/mA & RTD Inputs only)</i> Set the process value indication resolution (decimal point). All the resolution based parameters (Control Setpoint, Hysteresis, Alarm Setpoints etc.) then follow this resolution setting.</p>	<p>Refer Table 6.2 (Default : 1)</p>																											
<p>PV RANGE LOW r.Lo</p> <p><i>(Available for DC Linear Inputs)</i> Set process value corresponding to SIGNAL LOW parameter value. Refer <i>Appendix-A : DC Linear Signal Interface</i> for details.</p>	<p>-1999 to 9999 (Default : 0)</p>																											
<p>PV RANGE HIGH r.hi</p> <p><i>(Available for DC Linear Inputs)</i> Set process value corresponding to SIGNAL HIGH parameter value. Refer <i>Appendix-A : DC Linear Signal Interface</i> for details.</p>	<p>-1999 to 9999 (Default : 1000)</p>																											
<p>OFFSET FOR PV OFSE</p> <p>This value is algebraically added to the measured PV to derive the final PV that is displayed and compared for alarm / control.</p> <p>Final PV = Measured PV + Offset</p>	<p>For DC mA/mV/V : 1 to 9999 counts For Thermocouples/RTD : 1 to 999 or 0.1 to 999.9 (Default : 0)</p>																											
<p>DIGITAL FILTER TIME CONSTANT F.LT</p> <p>Set the time constant, in seconds, for the low-pass digital filter applied to the measured PV. The filter helps smoothing/averaging the signal input and removing the undesired noise.</p>	<p>0.5 to 60.0 Seconds (in steps of 0.5 Seconds) (Default : 2.0 sec.)</p>																											

Table 6.2

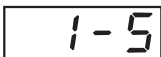
Option	What it means	Range (Min. to Max.)	Resolution
	Type J Thermocouple	0 to +960°C / +32 to +1760°F	Fixed 1°C / 1°F
	Type K Thermocouple	-200 to +1376°C / -328 to +2508°F	
	Type T Thermocouple	-200 to +385°C / -328 to +725°F	
	Type R Thermocouple	0 to +1770°C / +32 to +3218°F	
	Type S Thermocouple	0 to +1765°C / +32 to +3209°F	
	Type B Thermocouple	0 to +1825°C / +32 to +3092°F	
	Type N Thermocouple	0 to +1300°C / +32 to +2372°F	
	Reserved for customer specific Thermocouple type not listed above. The type shall be specified in accordance with the ordered (optional on request) Thermocouple type.		
	3-wire, RTD Pt100	-199 to +600°C / -328 to +1112°F or -199.9 to 600.0°C / -199.9 to 999.9°F	User settable 1°C / 1°F or 0.1°C / 0.1°F
	0 to 20mA DC current	-1999 to +9999 units	User settable 1 / 0.1 / 0.01/ 0.001 units
	4 to 20mA DC current		
	0 to 80mV DC voltage		
	Reserved		
	0 to 1.25V DC voltage		
	0 to 5.0V DC voltage		
	0 to 10.0V DC voltage		
	1 to 5.0V DC voltage		

Section 7

SUPERVISORY PARAMETERS : PAGE-13

Refer Table 7.1 for parameter description & settings.

Table 7.1

Parameter Description	Settings (Default Value)
SELF-TUNE COMMAND tUnE <i>(Available for PID control only)</i> Set to 'Yes' to initiate a new tuning cycle or set to 'No' to abort a tuning operation in progress.	<div style="display: flex; flex-direction: column; align-items: flex-end;"> <div style="display: flex; align-items: center; margin-bottom: 5px;"> <div style="border: 1px solid black; padding: 2px 5px; margin-right: 5px;">no</div> No </div> <div style="display: flex; align-items: center; margin-bottom: 5px;"> <div style="border: 1px solid black; padding: 2px 5px; margin-right: 5px;">YES</div> Yes </div> (Default : No) </div>
OVERSHOOT INHIBIT oS, h <i>(Available for PID control only)</i> Enabling this feature controls the rate of PV rise or fall upon process start-up in order to reach the control setpoint with minimum overshoot/undershoot possible.	<div style="display: flex; flex-direction: column; align-items: flex-end;"> <div style="display: flex; align-items: center; margin-bottom: 5px;"> <div style="border: 1px solid black; padding: 2px 5px; margin-right: 5px;">d5bL</div> Disable </div> <div style="display: flex; align-items: center; margin-bottom: 5px;"> <div style="border: 1px solid black; padding: 2px 5px; margin-right: 5px;">EnbL</div> Enable </div> (Default : Disable) </div>
OVERSHOOT INHIBIT FACTOR 0, h.F <i>(Available for PID control with Overshoot Inhibit enabled)</i> This parameter adjusts the effectiveness of the Overshoot Inhibit feature. Increase the value if the overshoot is curbed but the PV takes longer to reach the SP. Decreases the value if the overshoot persists.	<div style="display: flex; flex-direction: column; align-items: flex-end;"> 1.0 to 2.0 (Default : 1.0) </div>
SP ADJUSTMENT ON LOWER READOUT SP.Lr Supervisory permission for control setpoint editing on Lower Readout. Set to 'Enable' for permission.	<div style="display: flex; flex-direction: column; align-items: flex-end;"> <div style="display: flex; align-items: center; margin-bottom: 5px;"> <div style="border: 1px solid black; padding: 2px 5px; margin-right: 5px;">d5bL</div> Disable </div> <div style="display: flex; align-items: center; margin-bottom: 5px;"> <div style="border: 1px solid black; padding: 2px 5px; margin-right: 5px;">EnbL</div> Enable </div> (Default : Enable) </div>
SP ADJUSTMENT ON OPERATOR PAGE SP.OP Supervisory permission for control setpoint editing on Operator Page. Set to 'Enable' for permission.	<div style="display: flex; flex-direction: column; align-items: flex-end;"> <div style="display: flex; align-items: center; margin-bottom: 5px;"> <div style="border: 1px solid black; padding: 2px 5px; margin-right: 5px;">d5bL</div> Disable </div> <div style="display: flex; align-items: center; margin-bottom: 5px;"> <div style="border: 1px solid black; padding: 2px 5px; margin-right: 5px;">EnbL</div> Enable </div> (Default : Enable) </div>
MANUAL MODE HAnd Supervisory permission for Auto/Manual mode selection. Set to 'Enable' for permission.	<div style="display: flex; flex-direction: column; align-items: flex-end;"> <div style="display: flex; align-items: center; margin-bottom: 5px;"> <div style="border: 1px solid black; padding: 2px 5px; margin-right: 5px;">d5bL</div> Disable </div> <div style="display: flex; align-items: center; margin-bottom: 5px;"> <div style="border: 1px solid black; padding: 2px 5px; margin-right: 5px;">EnbL</div> Enable </div> (Default : Disable) </div>
ALARM SP ADJUSTMENT ON OPERATOR PAGE AL.SP Supervisory permission for Alarm setpoint adjustments on Operator Page. Set to 'Enable' for permission.	<div style="display: flex; flex-direction: column; align-items: flex-end;"> <div style="display: flex; align-items: center; margin-bottom: 5px;"> <div style="border: 1px solid black; padding: 2px 5px; margin-right: 5px;">d5bL</div> Disable </div> <div style="display: flex; align-items: center; margin-bottom: 5px;"> <div style="border: 1px solid black; padding: 2px 5px; margin-right: 5px;">EnbL</div> Enable </div> (Default : Disable) </div>
STANDBY MODE Stby Supervisory control over availability of Standby (entry / exit) command on Operator Page. 'Enable' for availability.	<div style="display: flex; flex-direction: column; align-items: flex-end;"> <div style="display: flex; align-items: center; margin-bottom: 5px;"> <div style="border: 1px solid black; padding: 2px 5px; margin-right: 5px;">d5bL</div> Disable </div> <div style="display: flex; align-items: center; margin-bottom: 5px;"> <div style="border: 1px solid black; padding: 2px 5px; margin-right: 5px;">EnbL</div> Enable </div> (Default : Disable) </div>

Parameter Description	Settings (Default Value)
<p>PROFILE ABORT COMMAND ON PAGE-1 Abrt</p> <p>Supervisory control over availability of Profile Abort command on Page-1. 'Enable' for availability.</p>	<p>d5bl Disable Enbl Enable (Default : Disable)</p>
<p>The Following Serial Communication Parameters are not available if the Controller is ordered with Auxiliary Setpoint Option.</p>	
<p>BAUD RATE bAud</p> <p>Communication speed in 'Bits per Second'. Set the value to match with the host baud rate.</p>	<p>24 2400 48 4800 96 9600 192 19200 384 38400 576 57600 (Default : 9.6)</p>
<p>COMMUNICATION PARITY PAR,</p> <p>One of the communication error trapping features. Select the data packet parity as implemented by the host protocol.</p>	<p>nonE None EuEn Even Odd Odd (Default : Even)</p>
<p>CONTROLLER ID NUMBER id</p> <p>Unique numeric code assigned to the controller for identification by the host. Set the value as required by the host.</p>	<p>1 to 127 (Default : 1)</p>
<p>COMMUNICATION WRITE ENABLE CoñE</p> <p>Setting to 'No' disallows the host to set or modify any parameter value. The host, however, can read the values.</p>	<p>no No YES Yes (Default : No)</p>



Section 8

PROFILE PARAMETERS : PAGE-16, PAGE-14, PAGE-1

Note : This Section is applicable only if the Controller is supplied with “Setpoint Profile” option.

The profile utility requires profile configuration and profile settings. Also, the controller facilitates on-line alterations of the parameters pertaining to the running segment. To simplify profile operation, the rather large list of parameters has been split in multiple pages as under.

Profile Configuration : PAGE-16

Use this list of parameters to configure the profile for number of segments, number of cycles (repeats), output(s) status upon profile completion and power fail recovery method. Refer Table 8.1 below.

Table 8.1









Parameter Description	Settings (Default Value)
PROFILE MODE ENABLE PrOF Enable or Disable the setpoint profile feature. If disabled, all the profile related parameters and commands are suppressed.	d5bL Disable EnbL Enable (Default : Disable)
NUMBER OF SEGMENTS n.SEG Set the number of segments to constitute the setpoint profile.	1 to 16 (Default : 16)
NUMBER OF REPEATS n.rPt Set the number of times the profile is to be repeated (cycled) before end of profile. After completion of the last segment of the running profile cycle, the profile restarts from the first segment.	1 to 9999 (Default : 1)
COMMON HOLDBACK CoHb The profile allows either <i>Common</i> or <i>Independent</i> 'Holdback Type' and 'Holdback Value' for all profile segments. Set this parameter to 'Yes' if common settings are desired for the Holdback feature.	no No YES Yes (Default : Yes)
OUTPUT OFF OPrOF Set to 'Yes' if after the end of profile, all the control outputs are to be <i>forced Off</i> till the issuance of next profile Start command.	no No YES Yes (Default : No)
POWER FAIL STRATEGY P.r.FL Selecting <i>Abort</i> terminates a running profile in case of power failure. Selecting <i>Continue</i> resumes : (a) The ramp segment execution with the profile setpoint prevailing at the time of power failure. (b) The soak segment execution for the balance time.	Abrt Abort Cont Continue (Default : Continue)

Profile Settings : PAGE-14

Note : The parameters on this page are available only if the profile feature is enabled on Page-16.

Use this list of parameters to set individual profile segment for the target setpoint, time interval, holdback type and value. Refer Table 8.2 below.

Table 8.2

Parameter Description	Settings (Default Value)
SEGMENT NUMBER  Select profile segment number for editing the following parameters.	1 to 16 (Default : 1)
TARGET SETPOINT  Set the Target (End) value for the selected profile segment number.	Min. to Max. Range specified for the selected Input Type (Default : -199)
TIME INTERVAL  Set the time duration of ramping or soaking for the selected profile segment number.	0 to 9999 Minutes (Default : 0)
HOLDBACK TYPE  Note : If the parameter 'Common Holdback' is set to 'Yes' on Page-16, then this parameter appears only for segment number 1 and is applied to all other segments. Disable the Holdback Band (Set None) or set the scope (up, down or both) for the profile holdback feature.	 None  Up  Down  Both (Default : None)
HOLDBACK VALUE  Note : If the parameter 'Common Holdback' is set to 'Yes' on Page-16, then this parameter appears only for segment number 1 and is applied to all other segments. Set the band (deviation from profile setpoint) value for the profile holdback feature.	For DC mA/mV/V : 1 to 9999 counts For Thermocouples/RTD : 1 to 999 or 0.1 to 999.9 (Default : 1)



On-line Alterations : PAGE-1

Note : The parameters on this page are available only if the profile feature is enabled on Page-16.

The profile facilitates altering the running segment of the profile for the current execution without affecting the profile settings on PAGE-14. That is, the changes made to the parameter values become applicable for the current execution of the segment only. This allows adjusting the profile, if required, in accordance to some unexpected process changes. Refer Table 8.3.

Table 8.3

Parameter Description	Settings (Default Value)
<p>END OF PROFILE ACKNOWLEDGE EOP.A</p> <p>This parameter is available if Output-2 and / or Output-3 Relay / SSR is programmed to turn ON as an 'End Of Profile' signal. Set this parameter to 'Yes' (after end of profile is reached) to acknowledge the alarm and to turn OFF the output.</p>	<p>no No YES Yes (Default : No)</p>
<p>PROFILE START COMMAND St.r.t</p> <p>PROFILE ABORT COMMAND Ab.r.t</p> <p>These parameters are mutually exclusive. Use <i>Start</i> command to commence a new profile cycle and <i>Abort</i> command to abort / terminate a running profile cycle. Set the value to 'Yes' to issue the command.</p>	<p>no No YES Yes (Default : No)</p>
<p>PROFILE PAUSE COMMAND PAUS</p> <p>This parameter is available while a profile cycle is in progress and can be used to Pause (halt) the profile as long as desired. Set the command to 'Yes' for Pausing and 'No' to continue. Under Pause state, the ramp segment stops ramping while the soak segment stops counting down the timer.</p>	<p>no No YES Yes (Default : No)</p>
<p>SEGMENT SKIP COMMAND SK IP</p> <p>Use this command to terminate a running profile segment and to move to the next segment. Skipping the last segment will result in completion of the current profile cycle.</p>	<p>no No YES Yes (Default : No)</p>
<p>The following parameters allow altering the running segment values (Time Interval, Holdback Band Type & Holdback Band Value) and Number of Repeats. The alterations made on the running segment are applicable only for the current execution of the profile cycle.</p>	
<p>SEGMENT TIME INTERVAL T.I.NE</p> <p>The time interval for a <i>Ramp</i> segment actually determines the RATE at which the setpoint steps towards the target setpoint. Thus, altering the time interval shall immediately affect the 'Ramp Rate' for the current segment.</p> <p>If the time interval is modified for the <i>Soak</i> segment then the time elapsed so far is ignored and the soak timer starts counting down to 0 from the altered time interval value.</p>	<p>0 to 9999 Minutes</p>
<p>SEGMENT HOLDBACK TYPE Hb.tY</p> <p>The modified Holdback Band Type is applied immediately on the current segment.</p>	<p>none None UP Up dn Down both Both</p>

Parameter Description	Settings (Default Value)
<p>SEGMENT BAND VALUE </p> <p>The modified Holdback Band Value is applied immediately on the current segment.</p>	<p>For DC mA/mV/V : 1 to 9999 counts For Thermocouples/RTD : 1 to 999 or 0.1 to 999.9</p>
<p>PROFILE REPEAT COUNTER </p> <p>This parameter shows the remaining profile cycles. If the value is altered, the repeat counter starts counting down from the new set value.</p>	<p>1 to 9999</p>



Section 9

OP1, OP2 & OP3 FUNCTION PARAMETERS : PAGE-15

Refer Table 9.1 for parameter description & settings.

Table 9.1

Parameter Description	Settings (Default Value)
<p>OUTPUT-1 TYPE OP1E</p> <p>Select the type in accordance with the hardware configuration for Output-1 (OP1).</p>	<p>rLY Relay</p> <p>SSr SSR</p> <p>0-20 0 - 20mA</p> <p>4-20 4 - 20mA</p> <p>0-5 0 - 5V</p> <p>0-10 0 - 10V</p> <p>(Default : Relay)</p>
<p>OUTPUT-2 FUNCTION SELECTION OP2F</p> <p><i>(Applicable for Output-2 hardware module, if fitted)</i></p> <p>Select the function / feature that will utilize Output-2 module as output.</p>	<p>nonE None</p> <p>AL_1 Alarm-1</p> <p>EOP End Of Profile</p> <p>CCon Cool Control</p> <p>(Default : None)</p>
<p>ALARM-1 LOGIC A1LG</p> <p><i>(Available if Output-2 function is Alarm-1 Output)</i></p> <p>Select 'Normal' if Alarm-1 is to activate an Audio / Visual alarm. Select 'Reverse' if Alarm-1 is to Trip the system.</p>	<p>nor\bar{n} Normal</p> <p>rEv Reverse</p> <p>(Default : Normal)</p>
<p>OUTPUT-2 TYPE OP2E</p> <p><i>(Available if Output-2 function is Cool Control)</i></p> <p>Select the type in accordance with the hardware configuration for Output-2 (OP2).</p>	<p>rLY Relay</p> <p>SSr SSR</p> <p>0-20 0 - 20mA</p> <p>4-20 4 - 20mA</p> <p>0-5 0 - 5V</p> <p>0-10 0 - 10V</p> <p>(Default : Relay)</p>
<p>OP2 EVENT STATUS O2ES</p> <p><i>(Available if Output2 function is End of Profile)</i></p> <p>Selecting 'ON' keeps the Output-2 OFF while profile is in progress and turns ON at the end of profile.</p> <p>Selecting 'OFF' keeps the Output-2 ON while profile is in progress and turns OFF at the end of profile.</p>	<p>On ON</p> <p>OFF OFF</p> <p>(Default : ON)</p>

Parameter Description	Settings (Default Value)
<p>OP2 EVENT TIME UNITS 02.UT</p> <p><i>(Available if Output-2 function is End of Profile & Event Status is set to 'ON')</i></p> <p>Select time units for the parameter 'Output-2 Event Time'.</p>	<p>SEC Seconds n in Minutes Hour Hours (Default : Seconds)</p>
<p>OP2 EVENT TIME 02.Et</p> <p><i>(Available if Output-2 function is End of Profile & Event Status is set to 'ON')</i></p> <p>Set the time (in selected units) for which the Output-2 status after the End of Profile is to be maintained. (For indefinite time interval, set the value to 0).</p>	<p>0 to 9999 (Default : 0)</p>
<p>OUTPUT-3 FUNCTION SELECTION OP3.F</p> <p><i>(Applicable for Output-3 hardware module, if fitted)</i></p> <p>Select the function / feature that will utilize Output-3 module as output.</p>	<p>none None AL_2 Alarm-2 EOP End Of Profile rEC Recorder (Default : Alarm)</p>
<p>ALARM-2 LOGIC A2LG</p> <p><i>(Available if Output-3 function is Alarm-2 Output)</i></p> <p>Select 'Normal' if Alarm-2 is to activate an Audio / Visual alarm. Select 'Reverse' if Alarm-2 is to Trip the system.</p>	<p>nor n Normal rEv Reverse (Default : Normal)</p>
<p>OUTPUT-3 EVENT STATUS 03.Es</p> <p><i>(Available if Output-3 function is End-of-Profile)</i></p> <p>Definition same as Output-2 Event Status .</p>	<p>On ON OFF OFF (Default : ON)</p>
<p>OUTPUT-3 EVENT TIME UNITS 03.UT</p> <p><i>(Available if Output-3 function is End of Profile & Event Status is set to 'ON')</i></p> <p>Definition same as Output-2 Event Time Units.</p>	<p>SEC Seconds n in Minutes Hour Hours (Default : Seconds)</p>
<p>OUTPUT-3 EVENT TIME 03.Et</p> <p><i>(Available if Output-3 function is End of Profile & Event Status is set to 'ON')</i></p> <p>Definition same as Output-2 Event Time.</p>	<p>0 to 9999 (Default : 0)</p>

Parameter Description	Settings (Default Value)
<p>RECORDER OUTPUT TYPE rEC.o</p> <p><i>(Available if Output-3 function is Recorder)</i></p> <p>Select type for Output-3 in accordance with the hardware module fitted.</p>	<p>0-20 0 to 20mA</p> <p>4-20 4 to 20mA</p> <p>0-5 0 to 5V</p> <p>0-10 0 to 10V</p> <p>(Default : 0 to 20mA)</p>



Section 10 HARDWARE ASSEMBLY AND CONFIGURATIONS

The Figure 10.1 below shows the controller outer-case viewed with front label upright.

Figure 10.1

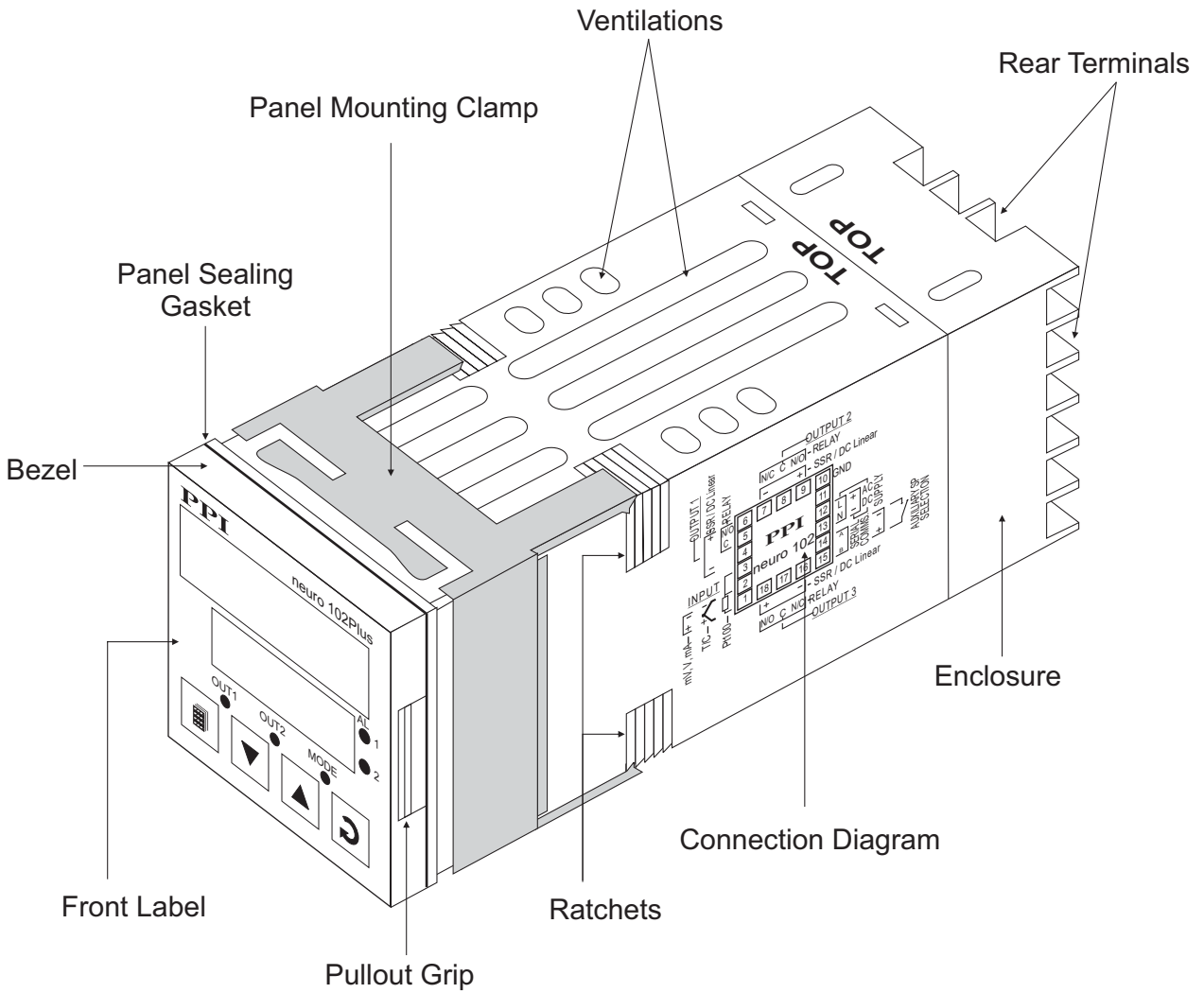

ELECTRONIC ASSEMBLY

The basic electronics assembly (without any plug-in modules), comprises of 3 Printed Circuit Boards (PCB). When viewed from the front; the CPU PCB is to the right, Power-supply PCB is to the left and the Display PCB is behind the bezel.

The electronic assembly can be removed from the plastic enclosure and placed back as described and illustrated in Figure 10.2.

Figure 10.2

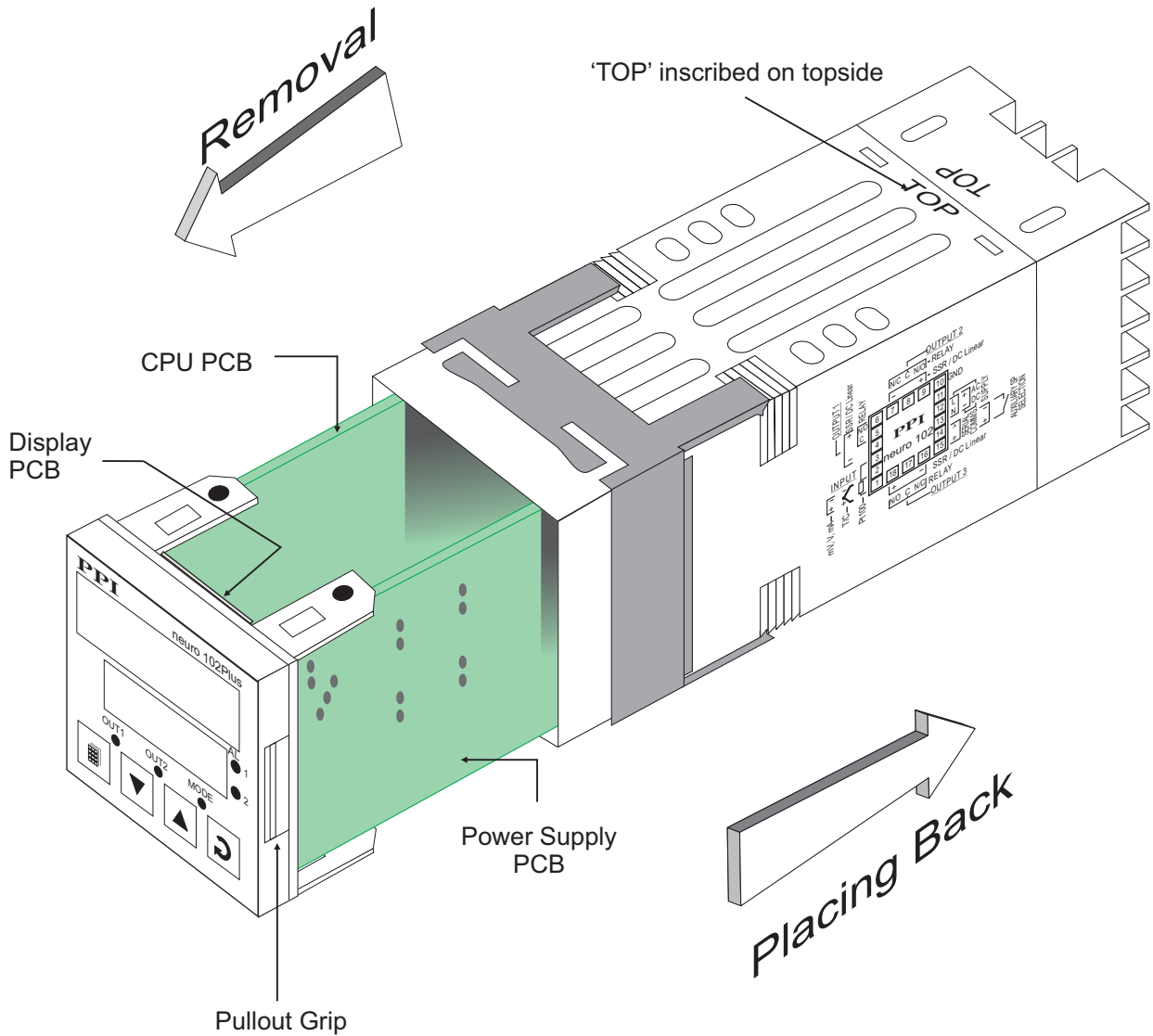

Removing Assembly from Enclosure

With the controller upright, hold the Bezel with the fingers on the pullout grips provided on the left and right sides of the bezel. Pull the bezel outward. The assembly comes out with the bezel.

Placing Assembly Back into Enclosure

With the controller upright (TOP inscribed on the Enclosure on the topside), insert the bezel gently with the boards on either side sliding into the guides provided inside of the Enclosure. Ensure that the bezel fits in tight on the Enclosure-front to secure the panel-sealing gasket.

Output-2 & Output-3 PLUG-IN MODULES

The controller supports Output-2 & Output-3 as optional plug-in modules. These modules are either pre-fitted while the controller is shipped from the factory or can be fitted by the user later. These modules are available as Relay / SSR or DC Linear Voltage or DC Linear Current and can fit in as output-2 or output-3 interchangeably. The Figure 10.3 & 10.4 below illustrate mounting of output-2 & output-3 modules, respectively.

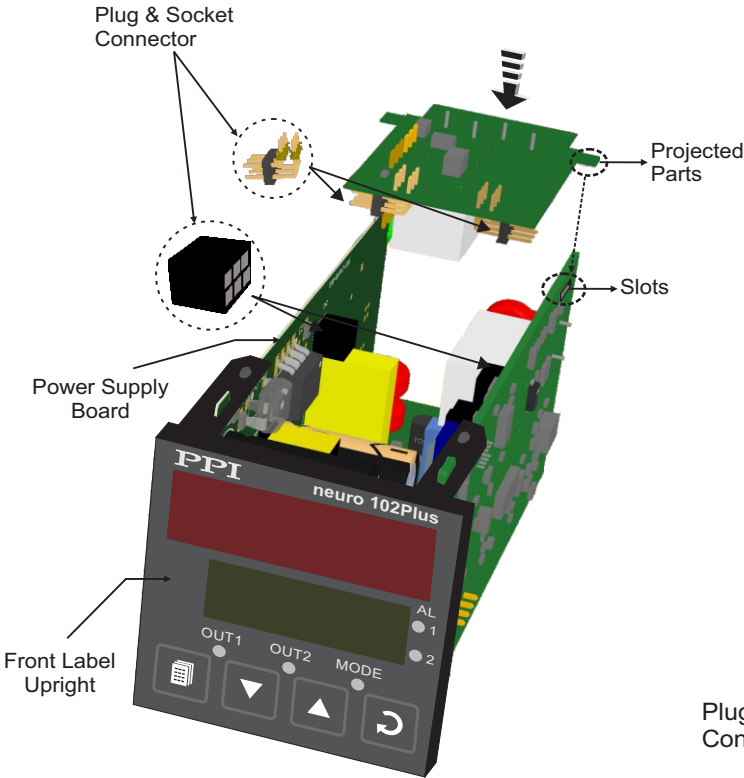

Figure 10.3
Mounting Output-2 Module

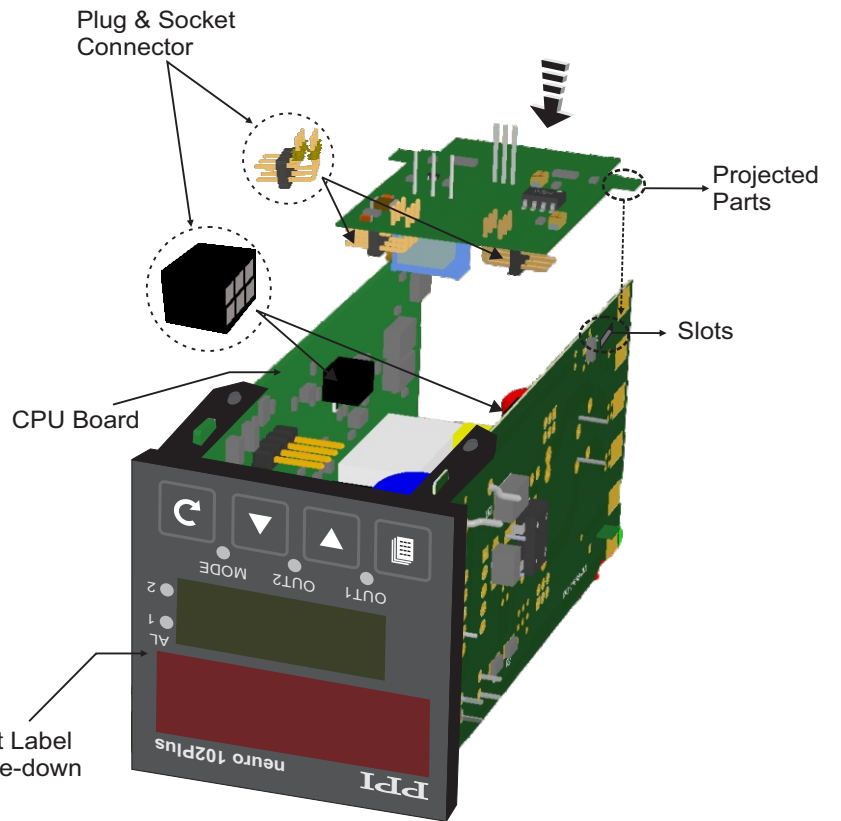
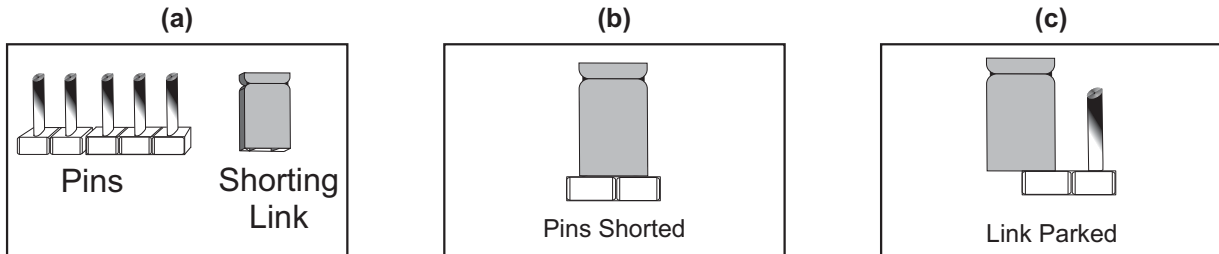

Figure 10.4
Mounting Output-3 Module

Jumper Settings

The Controller Outputs (Output-1, Output-2 & Output-3) can be configured for different types (Relay, SSR, DC Volts & DC Current) that require jumper settings besides appropriate parameter settings. The jumper settings are provided in the form of Pins & Shorting-Link arrangements as depicted in figures 10.5 below.

Figure 10.5 : Jumper Settings



OUTPUT-1 Configuration

The Output-1 circuit is assembled on CPU PCB itself with 2 jumper setting arrangements as shown in figure 10.6 below. Refer Table 10.1 for jumper setting arrangement to select different output type.

Figure 10.6

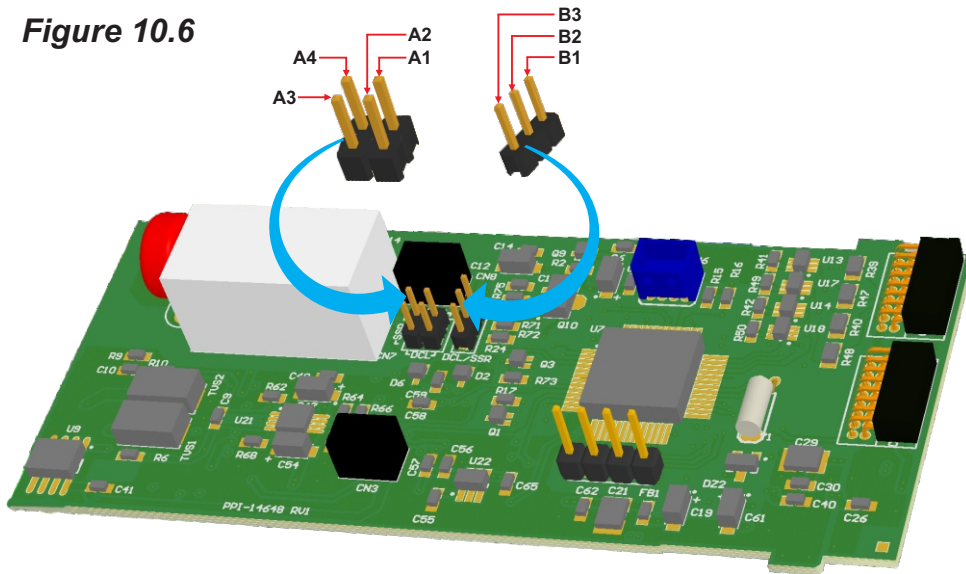

Table 10.1 : Output-1 Jumper Settings

Output Type	Jumper Settings
Relay	Shorting Link A : Short Pins A1 & A4 Shorting Link B : Park
SSR Drive	Shorting Link A : Short Pins A3 & A4 Shorting Link B : Short Pins B1 & B2
DC Linear Current (or Voltage)	Shorting Link A : Short Pins A2 & A3 Shorting Link B : Short Pins B2 & B3

Output-2 & Output-3 Relay / SSR Module Configuration

The output-2 & output-3 Relay / SSR Modules can be configured for either Relay output or SSR output by appropriate Jumper Settings. Refer Figure 10.7 & Table 10.2 below.

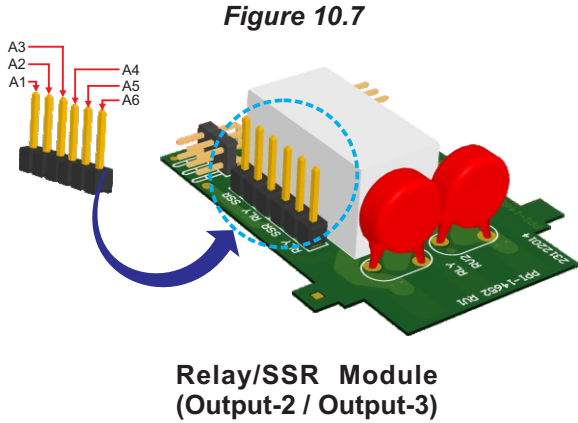

Table 10.2

Output Type	Jumper Setting (Used 2 Short Links)
Relay	Short pins A2 & A3 and Short pins A5 & A6
SSR	Short pins A1 & A2 and Short pins A4 & A5

Output-2 & Output-3 DC Linear Voltage / Current Modules

The DC Linear Module is factory configured for either Current or Voltage output. The current output can be configured for 0-20 mA or 4-20 mA and similarly the voltage output can be configured for 0-5 V or 0-10 V through parameter settings. No Jumper Settings are required.

Serial Communication or Auxiliary SP Selection PLUG-IN MODULES

The plug for the Serial Communication or Auxiliary SP Selection module is located on the Power-supply PCB. The Figure 10.8 below illustrates how to plug-in the Serial Communication/Auxiliary SP module. To plug (or unplug) the module simply insert (or remove) the socket into (or from) the plug. Refer Figure 10.8 below.

Figure 10.8

Mounting Serial Communication/Auxiliary SP Selection Module

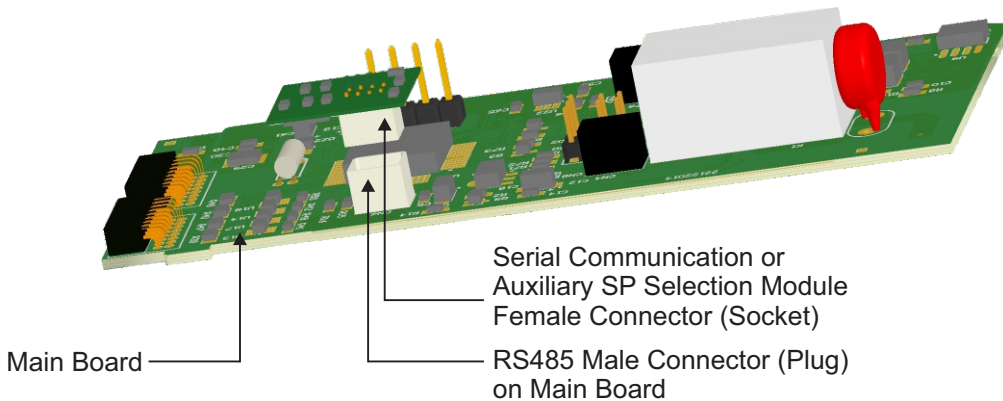

Section 11 MECHANICAL INSTALLATION

The following precautions should be strictly observed while installing the controller:

1. The place of installation should be free of corrosive/combustible gases and electrically conductive pollution.
2. Ensure that the place of installation is not subject to rapid ambient changes that can cause condensation. Also the Ambient Temperature and Relative Humidity surrounding the controller should not exceed the maximum specified for the proper operation of the controller.
3. The place of installation should be adequately protected against excessive electrostatic or electromagnetic interference.
4. The controller should not be subject to direct vibration or shock.
5. The controller should not be exposed to dust, salt air, direct sunlight or radiant heat.

OUTER DIMENSIONS

The Figure 11.1 shows the outer dimensions of the controller.

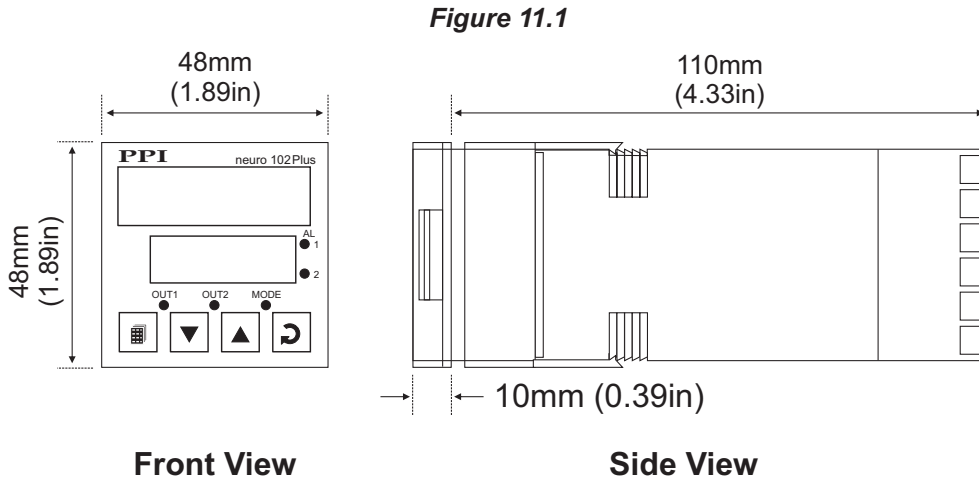

PANEL CUTOUT AND RECOMMENDED MINIMUM SPACING

The Figure 11.2 shows the panel cutout requirements for a single controller and also the minimum spacing recommended if several controllers are required to be mounted on a single panel.

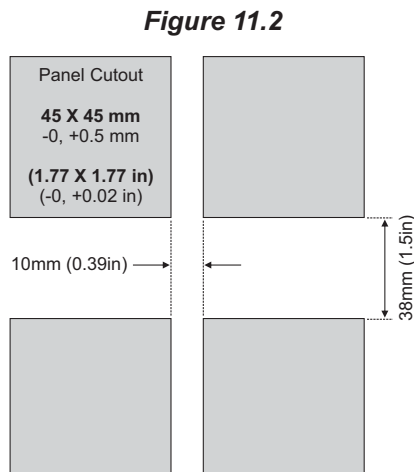

PANEL MOUNTING

Follow the steps below for mounting the controller on panel:

1. Prepare a square cutout to the size shown in Figure 11.2.
2. Remove the Panel Mounting Clamp from the controller Enclosure.
3. Insert the rear of the controller housing through the panel cutout from the front of the mounting panel.
4. Hold the controller gently against the mounting panel such that it positions squarely against the panel wall, see Figure 11.3. Apply pressure only on the bezel and not on the front label.
5. Slide the mounting clamp forward until it is firmly in contact with the rear face of the mounting panel and the tongues of the clamp engage in the ratchets on the controller enclosure, as shown in Figure 11.3. Ensure that the springs of the clamp push firmly against the rear face of the mounting panel for secured mounting.

Figure 11.3

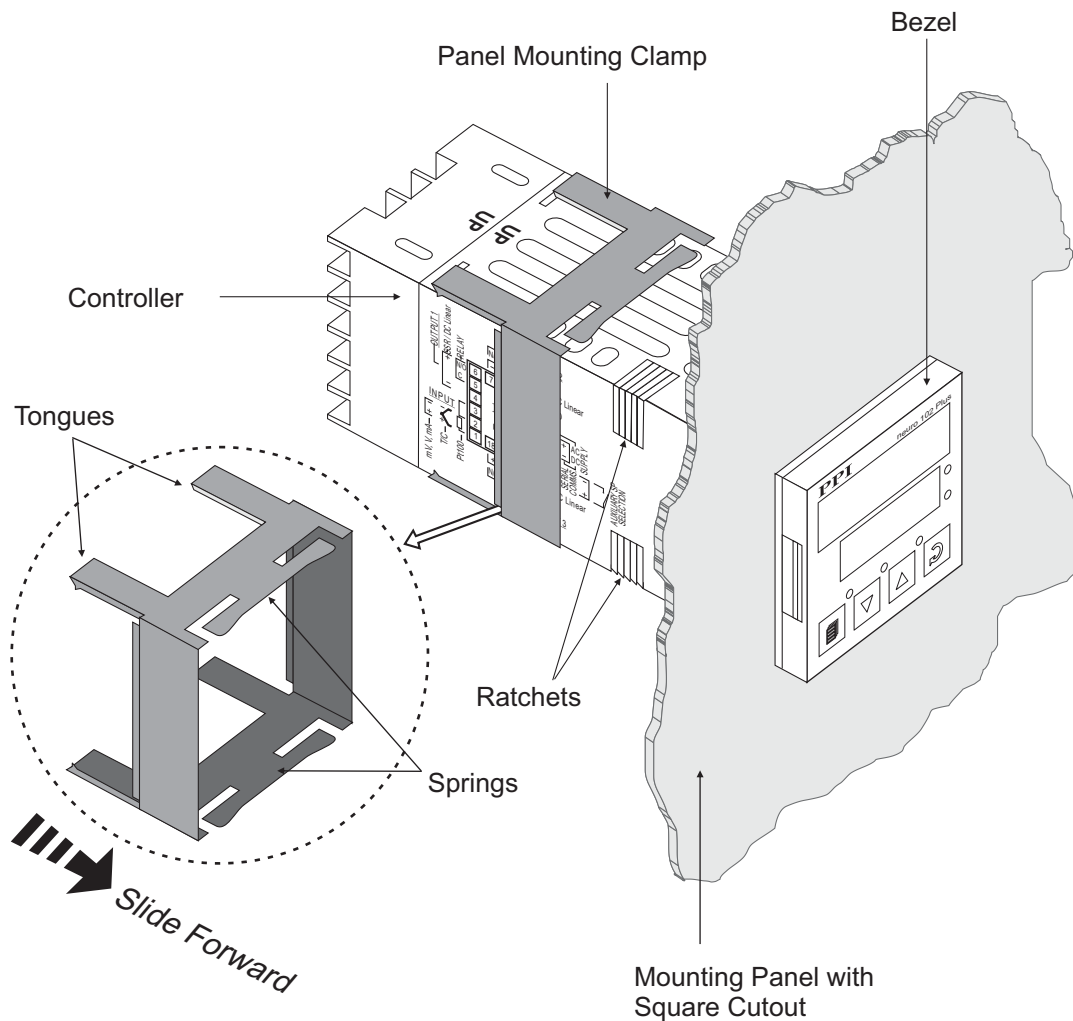

Section 12 ELECTRICAL CONNECTIONS

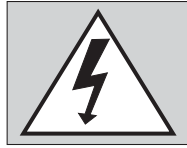

WARNING
MISHANDLING / NEGLIGENCE
CAN RESULT IN PERSONAL DEATH
OR SERIOUS INJURY.

1. The user must rigidly observe the Local Electrical Regulations.
2. Do not make any connections to the unused terminals for making a tie-point for other wires (or for any other reasons) as they may have some internal connections. Failing to observe this may result in permanent damage to the controller.
3. Run power supply cables separated from the low-level signal cables (like Thermocouple, RTD, DC Linear Current/Voltage, etc.). If the cables are run through conduits, use separate conduits for power supply cable and low-level signal cables.
4. Use appropriate fuses and switches, wherever necessary, for driving the high voltage loads to protect the controller from any possible damage due to high voltage surges of extended duration or short-circuits on loads.
5. Take care not to over-tighten the terminal screws while making connections.
6. Make sure that the controller supply is switched-off while making/removing any connections or removing the controller from its enclosure.

CONNECTION DIAGRAM

The Electrical Connection Diagram is shown on the right side of the controller enclosure. The diagram shows the terminals viewed from the REAR SIDE with the controller label upright. Refer the label provided on the Rear Side for terminal numbers. The Connection Diagram is a generic one; the connections shown for optional modules are applicable only if the modules are fitted.

The rear panel electrical wiring connection diagrams are shown in Figure 12.1(a) & 12.1(b) below for Old & New Versions, respectively.

Figure 12.1 : Old Version

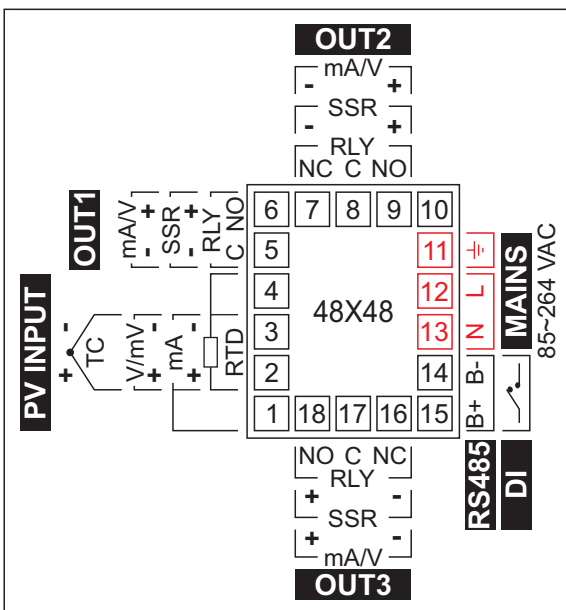
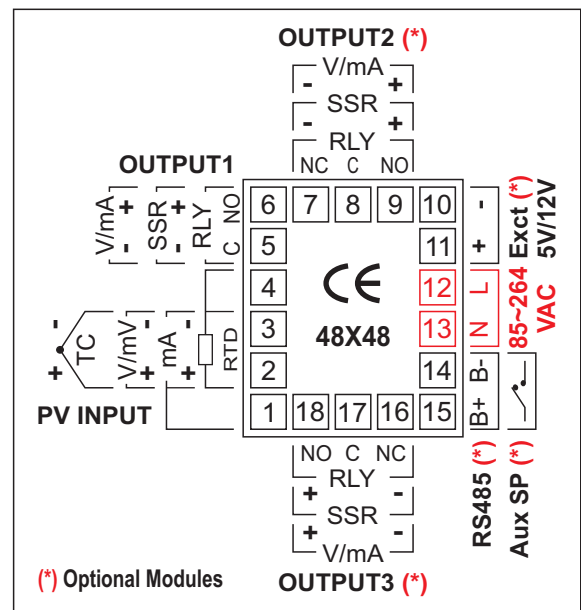

Figure 12.1 : New Version



DESCRIPTIONS

The back panel connections are described as under:

PV INPUT (Terminals : 1, 2, 3, 4)

The controller accepts Thermocouples (J, K, T, R, S, B, N & Reserved), 3-wire RTD Pt100 and DC Linear Current / Voltage (mV/V/mA) as input.

Thermocouple

Connect Thermocouple Positive (+) to terminal 2 and Negative (-) to terminal 3 as shown in Figure 12.2 (a). Use the correct type of Thermocouple extension lead wires or compensating cable for the entire distance ensuring the correct polarity throughout. Avoid joints in the cable.

Figure 12.2 (a)

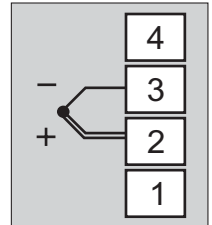

RTD Pt100, 3-wire

Connect single lead end of RTD bulb to terminal 2 and the double lead ends to terminal 3 and 4 (interchangeable) as shown in Figure 12.2 (b). Use copper conductor leads of very low resistance ensuring that all 3 leads are of the same gauge and length. Avoid joints in the cable.

Figure 12.2 (b)

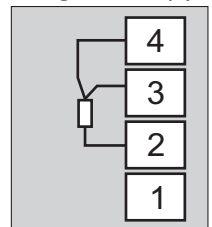

DC Linear Voltage (mV / V)

Connect Signal (+) to terminal 2 & Common (-) to terminal 3, as shown in Figure 12.2 (c). Use a shielded twisted pair with the shield grounded at the signal source for connecting mV / V source.

Figure 12.2 (c)

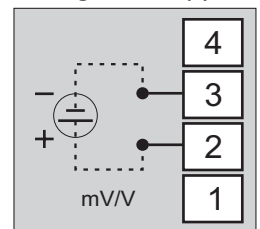

DC Linear Current (mA)

Connect Signal (+) to terminal 2 & Common (-) to terminal 3. Also **short** terminals 1 & 2. Refer Figure 12.2 (d). Use a shielded twisted pair with the shield grounded at the signal source for connecting mA source.

Figure 12.2 (d)

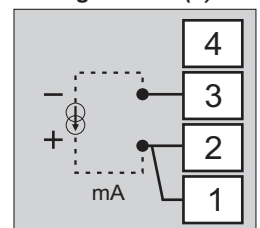

OUT1 (Terminals : 5, 6)

The Output-1 can be configured (through jumper settings) as either Relay, SSR Drive or DC Linear Current (or Voltage).

Relay

Potential-free changeover contacts NO (Normally Open) and C (Common) rated 2A/240 VAC (resistive load) are provided as Relay output. Use external auxiliary device like contactor with appropriate contact rating for driving the actual load.

Figure 12.3 (a)

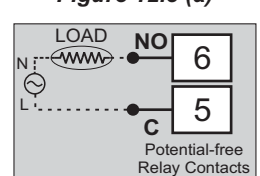

Drive for SSR

DC Voltage level is generated for switching the external SSR (Solid State Relay). Connect (+) and (-) terminals of SSR to controller terminals 6 and 5, respectively. Use Zero-Crossover, 3 to 30 VDC operated SSR, rated approximately 1.5 times the actual load rating. Use appropriate Heat Sink for load rating exceeding 10A.

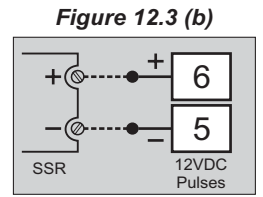

DC Linear Current / Voltage Output

If the Output-1 is configured for DC Linear (mA/V), connect the power module (like Thyristor, SCR, I/P Converter, etc.) as shown in figure 12.3 (c).

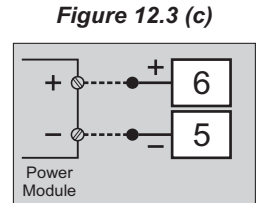

OUTPUT-2 (Terminals : 7, 8, 9)

OUTPUT-3 (Terminals : 16, 17, 18)

The Output-2 and Output-3 are available through plug-in modules. The modules are factory configured for either Relay / SSR or DC Linear Voltage or DC Linear Current. The connection descriptions are the same as those described for Output-1.

Refer Figure 12.4(a), 12.4(b) & 12.4(c)

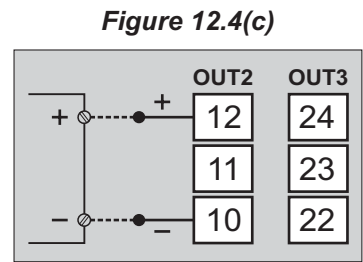
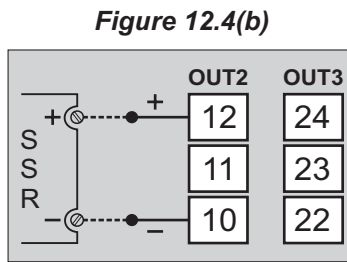
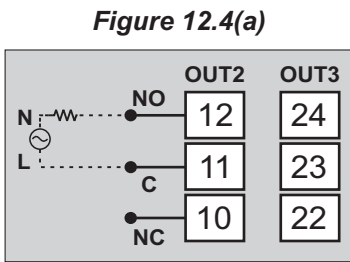

5 VDC or 12 VDC EXCITATION VOLTAGES (Terminals : 10, 11)

The Excitation Voltage is available optionally.

The 12 VDC @ 40 mA is primarily meant for exciting 2-wire or 4-wire current output transmitters. The 5 VDC @ 15 mA is primarily meant for connecting 3-wire mV/V output transmitters.

Terminal 10 & 11 are Common (ground) and Signal output, respectively.

SERIAL COMMUNICATION PORT (Terminals : 14, 15) Or

DIGITAL INPUT FOR AUXILIARY SP SELECTION (Terminals : 14, 15)

Note :

If the Controller is ordered with Auxiliary Setpoint feature, the digital input for Main & Auxiliary Setpoint selection is provided on terminals 14 & 15. The Serial Communication Port option is thus not available.

If the Optional plug-in communication board is fitted, connect terminal 14 and 15 of the controller to (+) and (-) terminals of the Master device as shown in figure 12.5. For reliable noise free communication, use a pair of twisted wires inside screened cable as shown in Figure 12.5. The wire should have less than 100 ohms / km nominal DC resistance (Typically 24 AWG or thicker). Connect the terminating resistor (Typically 100 to 150 ohm) at one end to improve noise immunity.

Figure 12.5

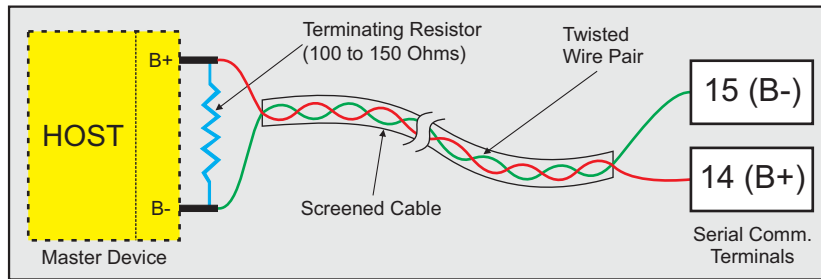

The Digital Input for selecting Auxiliary SP is potential-free contact closure. The Setpoint selection is as shown in figure 12.6.

Figure 12.6

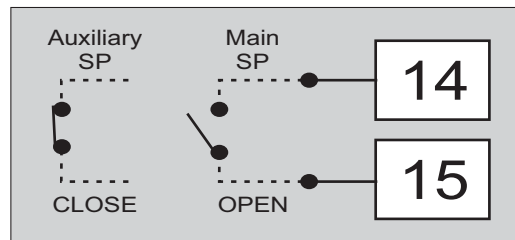

POWER SUPPLY (Terminals Old Version : 11, 12, 13 / Terminals New Version : 12, 13)

Figure 12.7

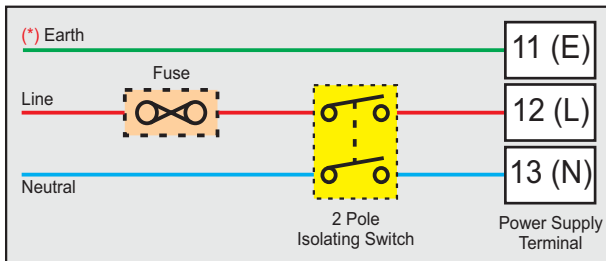

Caution

The controller is designed for installation in an enclosure which provides adequate protection against electric shock. Local regulations regarding electrical installation should be rigidly observed. Consideration should be given to prevention of access to the Power Supply terminals by unauthorized personnel.

As standard, the controller is supplied with power connections suited for 85 to 264 VAC line supply. Use well-insulated copper conductor wire of the size not smaller than 0.5mm² for power supply connections. Connect Line (Phase) supply line to terminal 12 and the Neutral (Return) supply line to terminal 13 as shown in Figure 12.7. The controller is not provided with fuse and power switch. If necessary, mount them separately. Use a time lag fuse rated 1A @ 240 VAC.

All earth terminals must be securely connected directly to a good local earth by conductors appropriate to the current rating of the units.

To avoid possible shock hazards in the event of an internal fault causing breakdown of insulation, it is recommended that all equipment connected to any PPI unit be enclosed in an earthed metal enclosure. Sheaths of thermocouples (or other sensors) should be properly earthed by a separate conductor (instead of being dependent on earthing via the machine framework).

(*) Earth Terminal is not provided in New Version.

APPENDIX - A

DC LINEAR SIGNAL INTERFACE

This appendix describes the parameters required to interface process transmitters that produce Linear DC Voltage (mV/V) or Current (mA) signals in proportion to the measured process values. A few examples of such transmitters are;

1. Pressure Transmitter producing **4 to 20 mA** for **0 to 5 psi**
2. Relative Humidity Transmitter producing **1 to 4.5 V** for **5 to 95 %RH**
3. Temperature Transmitter producing **0 to 20 mA** for **-50 to 250 °C**

The instrument (indicator/controller/recorder) that accepts the linear signal from the transmitter computes the measured process value by solving the mathematical equation for Straight-Line in the form:

$$Y = mX + C$$

Where;

- X : Signal Value from Transmitter
- Y : Process Value Corresponding to Signal Value X
- C : Process Value Corresponding to X = 0 (Y-intercept)
- m : Change in Process Value per unit Change in Signal Value (Slope)

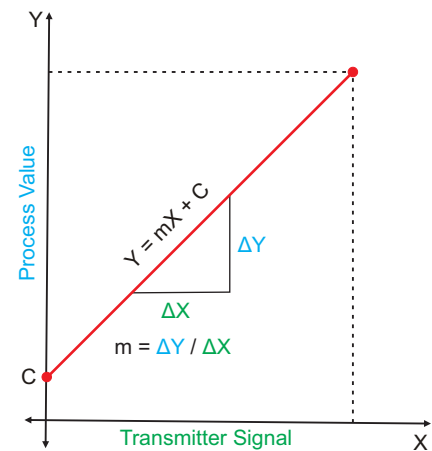

As is evident from the aforementioned transmitter examples, different transmitters produce signals varying both in type (mV/V/mA) and range. Most PPI instruments, thus, provide programmable Signal Type and Range to facilitate interface with a variety of transmitters. A few industry standard signal types and ranges offered by the PPI instruments are: 0-50mV, 0-200mV, 0-5 V, 1-5 V, 0-10V, 0-20 mA, 4-20 mA, etc.

Also, the output signal range (e.g. 1 to 4.5 V) from different transmitters corresponds to different process value range (e.g. 5 to 95 %RH); the instruments thus also provide facility for programming the measured process value range with programmable Resolution.

The linear transmitters usually specify two signal values (Signal Low and Signal High) and the corresponding Process Values (Range Low and Range High). In the example Pressure Transmitter above; the Signal Low, Signal High, Range Low & Range High values specified are: 4 mA, 20 mA, 0 psi & 5 psi, respectively.

In summary, the following 6 parameters are required for interfacing Linear Transmitters:

1. Input Type : Standard DC Signal Type in which the transmitter signal range fits (e.g. 4-20 mA)
2. Signal Low : Signal value corresponding to Range Low process value (e.g. 4 mA)
3. Signal High : Signal value corresponding to Range High process value (e.g. 20 mA)
4. PV Resolution : Resolution (least count) with which to compute process value (e.g. 0.01)
5. Range Low : Process value corresponding to Signal Low value (e.g. 0.00 psi)
6. Range High : Process value corresponding to Signal High value (e.g. 5.00 psi)

The following examples illustrate appropriate parameter value selections.

Example 1: Pressure Transmitter producing 4 to 20 mA for 0 to 5 psi

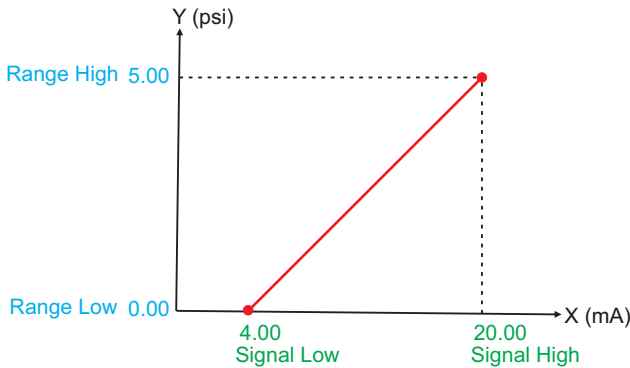

Presume the pressure is to be measured with 0.01 Resolution, that is 0.00 to 5.00 psi.

Input Type	: 4-20 mA
Signal Low	: 4.00 mA
Signal High	: 20.00 mA
PV Resolution	: 0.01
Range Low	: 0.00
Range High	: 5.00

Example 2: Relative Humidity Transmitter producing 1 to 4.5 V for 5 to 95 %RH

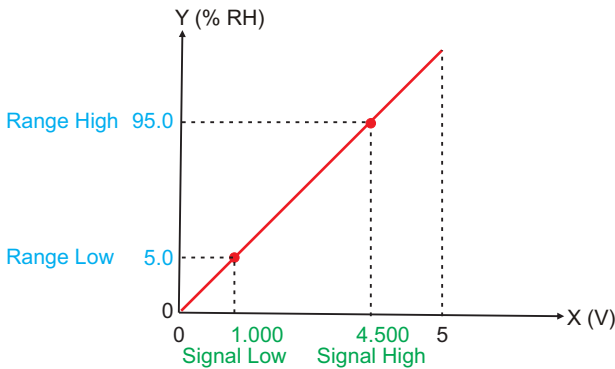

Presume the humidity is to be measured with 0.1 Resolution, that is 0.0 to 100.0 %.

Input Type	: 0-5 V
Signal Low	: 1.000 V
Signal High	: 4.500 V
PV Resolution	: 0.1
Range Low	: 5.0
Range High	: 95.0

Example 3: Temperature Transmitter producing 0 to 20 mA for -50 to 250 °C

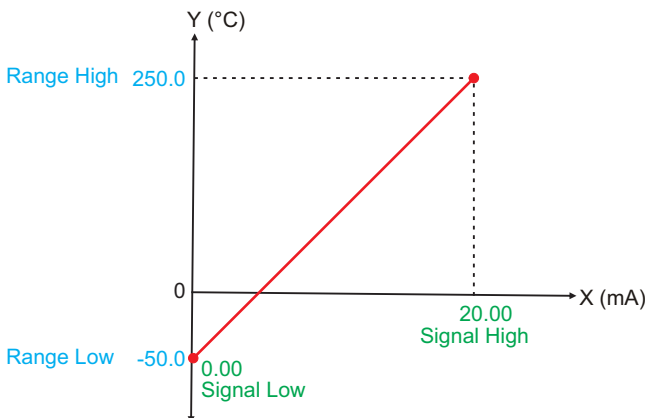

Presume the Temperature is to be measured with 0.1 Resolution, that is -50.0 to 250.0°C.

Input Type	: 0-20 mA
Signal Low	: 0.00 mA
Signal High	: 20.00 mA
PV Resolution	: 0.1
Range Low	: -50.0
Range High	: 250.0





PPI
The Perfection Experts

Process Precision Instruments

101, Diamond Industrial Estate, Navghar, Vasai Road (E),
Dist. Palghar - 401 210. Maharashtra, India



Sales : 8208199048 / 8208141446

Support : 07498799226 / 08767395333



sales@ppiindia.net, support@ppiindia.net