

Features

- Universal Input (Thermocouples, RTD Pt100, DC Linear mA/mV/V)
- Universal Control Output (Relay / SSR Drive / DC Linear)
- Programmable Range / Resolution for DC Linear Inputs
- Programmable Input Signal Conditioning (Digital Filter & Zero Offset)
- 16 Profiles (Programs) of 16 Segments Each (8 Ramp + 8 Soak)
- Facility to Link Programs to Build Larger Profiles (Upto 256 Segments)
- Programmable Hold Band for Each Profile
- Online Profile Pause, Segment Skip / Advance
- Programmable Repeat Cycles for Each Profile
- Optional Programmable Event Outputs per Segment
- Self Tune PID, On-Off, Manual Control Mode
- Uni-Directional / Bi-Directional Control
- Optional Programmable Alarms / Retransmission Outputs
- Optional Serial Communication Port
- Sizes (mm) : 48(H) X 48(W) X 110(D), 96(H) X 96(W) X 65(D)



Specifications

Display	
Digital Readout 48 X 48	Upper Readout : 4 digits, 0.39" Bright Red LED, 7 Segment Lower Readout : 4 digits, 0.3" Luminous Green LED, 7 Segment
Digital Readout 96 X 96	Upper Readout : 4 digits, 0.56" Bright Red LED, 7 Segment Lower Readout : 4 digits, 0.56" Luminous Green LED, 7 Segment
Status Indicators	5 Red LEDs (3mm Round)
Keys	
Type	4 Tactile Switches
Functions	PAGE, DOWN, UP, ENTER
Sensor / Signal Input	
Type (User Programmable)	Thermocouple : J, K, T, R, S, B, N RTD Pt100, 3 wire DC Linear : 0-20 mA, 4-20 mA 0-50 mV, 0-200 mV 0-1.25 V, 0-5 V, 0-10 V, 1-5 V
Corrections	<ul style="list-style-type: none"> • In-built Cold-Junction Compensation for Thermocouples • In-built Lead Resistance Compensation for RTD (Upto 22 Ohms in each lead)
Accuracy	For Thermocouples & RTD : $\pm 0.25\%$ of reading $\pm 1^\circ\text{C}$ For DC Linear Volts / Current : $\pm 0.25\%$ of reading ± 1 LSD
Display Range	Refer Table 1 for Thermocouples & RTD Inputs Adjustable from -1999 to 9999 Counts for DC Linear mA/mV/V
Display Resolution (User Programmable)	Thermocouples : 1°C Fixed RTD Pt100 : $0.1 / 1^\circ\text{C}$ DC Linear Volts / Current : 0.001 / 0.01 / 0.1 / 1 Counts
Zero Offset	User Adjustable over Full Range
ADC	16 Bit ($\pm 32,768$ Counts), Sigma-Delta ($\Sigma\Delta$)
Sampling Time	200mS (5 Samples per Second)
Input Resistance	> 8 MOhm
Common Mode Rejection	> 100dB at 50/60 Hz
Signal Conditioning	L-C Analog Filter with Programmable Digital Low-Pass Filter

Alarms	
Numbers	2, Independent
Programmable Parameters	Type : Process Low, Process High, Deviation, Window Logic : Normal, Reverse Hysteresis : 1 to 999 Unit Counts Inhibit : No, Yes
Outputs (Optional)	Relay Change-over Contacts or SSR Drive (Jumper Selectable) Output-2 (OP-2) for Alarm-1, Output-3 (OP-3) for Alarm-2
Retransmission	
Parameter Type	Process Value (PV) or Setpoint (SP)
Parameter Value	User Settable through 'Range Low' & 'Range High' Parameters
Output Signal	DC Volts (0-5/10 V) or DC Current (0/4-20 mA)
Control	
Type	ON-OFF Or Self Tune PID
Mode	Heat only, Cool only, Heat & Cool
Control Parameters	<ul style="list-style-type: none"> ON-OFF : Hysteresis Self Tune PID : Proportional Band, Integral Time, Derivative Time, Cycle Time, Relative Cool Gain, Power Low, Power High, Overshoot Inhibit
Manual Control	Bump-less Transfer between Auto PID and Manual Control through front panel Key
Setpoint Profile	
Programs	4 / 8 / 12 / 16 Programs of 16 Segments (8 Ramp + 8 Soak) each
Hold Back Band	Separate Ramp Band and Soak Band for each Profile
Event Outputs	2 Per Segment Per Profile
Power-fail Recovery	Servo Start
Outputs (Refer Table 2 : Output Option Selection & Function Assignments)	
Relay	Contact Type : Potential-free Change-over Contacts Contact Rating : 5A Resistive @ 120/240 Vac Contact Life : > 5,00,000 Operations at Rated Voltage / Current
SSR Drive	> 4.2 VDC into 1KOhm Minimum
DC Linear	Voltage : 0-5V, 0-10V (into 1KOhm Minimum) Current : 0-20mA, 4-20mA (into 500 Ohm Maximum)
Serial Communication	
Port	RS485, 2-wire, Half Duplex, Start-Stop Synchronized
Protocol	Modbus RTU
Baud Rate	Settable : 1200, 2400, 4800, 9600
Max. Units per Loop	31
Max. Distance	1200 Meters

Power Supply	
Type	Switch Mode (SMPS)
Line Voltage	Standard : 85~264 VAC, 50/60Hz Optional : 18~36 VDC
Consumption	5VA Max
Physical	
Mounting	Plug-in with Panel Mounting Clamps
Overall Dimensions	48(H) X 48(W) X 110(D), mm 96(H) X 96(W) X 65(D), mm
Panel Cutout	45(H) X 45(W), mm 92(H) X 92(W), mm
Terminals	Screw Type
Weight	48 X 48 : 225 gm, Appx. 96 X 96 : 400 gm, Appx.
Environmental	
Operating Ambient	0~55°C & 5~90%RH Non-condensing
Storage Temperature	-10 to +70 °C
EMC Standards	EN50081-2 & EN 50082-2 Generic Stds for Industrial Environment
Safety Standards	Meets EN61010, Installation Catagory II
Atmospheres	Not Suitable for use in Corrosive or Explosive Atmospheres. The Panel in which the Instrument is Mounted must be free of Electrically Conductive Pollution.

Back Panel Terminations

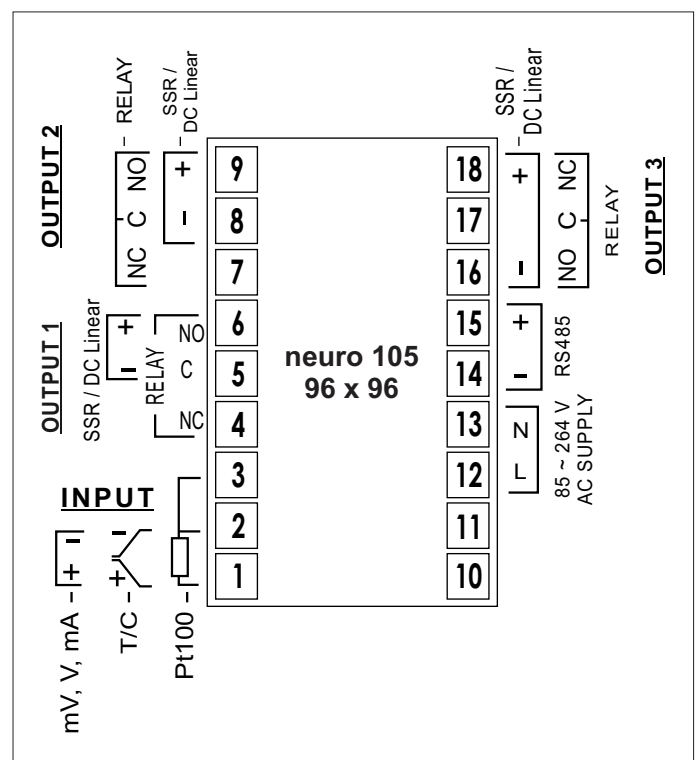
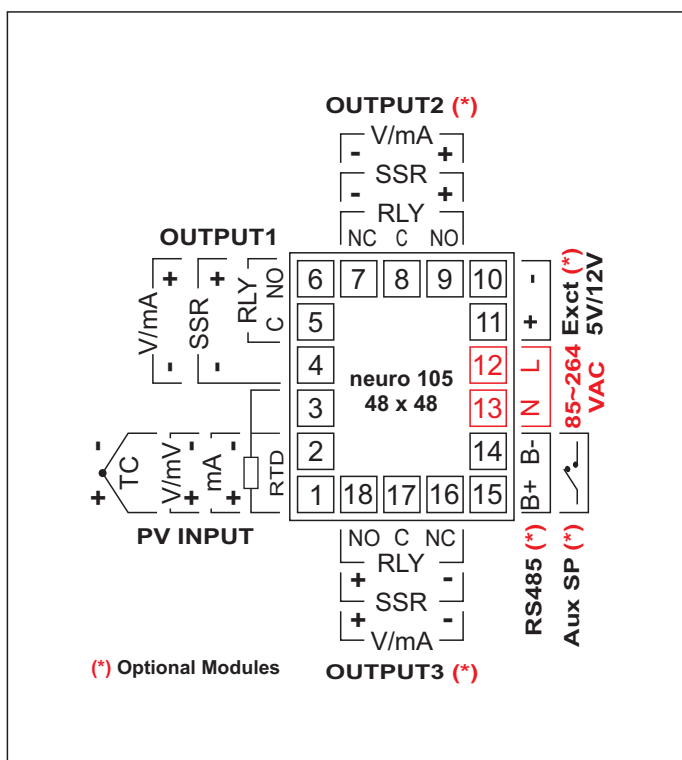

Table 1 : Temperature Ranges for Thermocouples & RTD

Input Type	Range (Min. to Max.)
Type J Thermocouple (Fe-K)	0 to +960°C
Type K Thermocouple (Cr-Al)	-200 to +1376°C
Type T Thermocouple (Cu-Con)	-200 to +385°C
Type R Thermocouple (Pt/Pt-Rh13%)	0 to +1770°C
Type S Thermocouple (Pt/Pt-Rh10%)	0 to +1765°C
Type B Thermocouple	0 to +1825°C
Type N Thermocouple	0 to +1300°C
3-wire, RTD Pt100	-199 to +600°C or -199.9 to 600.0°C

Table 2 : Output Option Selection & Function Assignments

	Available Options (Specify while Ordering)	Function Assignments (User Programmable)
Output-1 (OP-1)	<input type="checkbox"/> Relay, SSR & 0/4-20 mA (Jumper Selectable) <input type="checkbox"/> Relay, SSR & 0-5/10 V (Jumper Selectable)	✓ Main Control Output
Output-2 (OP-2)	<input type="checkbox"/> Relay, SSR (Jumper Selectable) <input type="checkbox"/> 0-5/10 V <input type="checkbox"/> 0/4-20 mA	✓ Cool Control Output ✓ Alarm-1 Output ✓ Profile Event Output
Output-3 (OP-3)	<input type="checkbox"/> Relay, SSR (Jumper Selectable) <input type="checkbox"/> 0-5/10 V <input type="checkbox"/> 0/4-20 mA	✓ Alarm-2 Output ✓ Profile Event Output ✓ Retransmission Output

Ordering Code

Input*		Output 1***		Output 2		Output 3		Power Supply		Options		Size	
TC	Thermocouple	1C	Relay	0	None	0	None	0	85~264 VAC	N	None	48	48 X 48
PT	RTD Pt100	1V	Relay	1	Relay**	1	Relay**			S	Serial Port	96	96 X 96
LV	Linear Voltage	2C	SSR	2	SSR**	2	SSR**						
LC	Linear Current	2V	SSR	3	0-5/10 V	3	0-5/10 V						
		3V	0-5/10 V	4	0/4-20 mA	4	0/4-20 mA						
		4C	0/4-20 mA										

Example Code **TC-4C-1-4-0-S-48**

Thermocouple Input, Output-1 0/4-20 mA, Output-2 Relay, Output-3 0/4-20 mA (Retransmission), 85~264 VAC Supply, Serial Port, 48 X 48

- * Input type is universal and requires appropriate jumper settings. The ordering code only implies the factory settings at the time of dispatch.
- ** Relay and SSR selection is jumper settable by user. The ordering code only implies the factory settings at the time of dispatch if Relay/SSR output option is ordered .
- *** Output-1 is universal with ordering code comprising two characters. The first character specifies the factory jumper setting and the second character specifies one of the following output options.

C	Relay, SSR & 0/4-20 mA
V	Relay, SSR & 0-5/10 V