



Features

- Universal Input (Thermocouples, RTD Pt100, DC Linear mA/mV/V)
- Programmable Range / Resolution for DC Linear Inputs
- Programmable Input Signal Conditioning (Digital Filter & Zero Offset)
- 32 Point User Defined Linearization for DC Linear Input
- Facility to View & Store Min/Max Process Value
- °C / °F Units Selection for Thermocouples / RTD Pt100 Inputs
- 2 Programable Alarms with Optional Relay Outputs
- Retransmission Output (0/4-20 mA)
- Optional Serial Communication Port
- DIN Standard Dimensions (mm) : 48(H) X 48(W) X 110(D)

96(H) X 96(W) X 65(D)



Specifications

Display	
Digital Readout 48 X 48	Upper Readout : 4 digits, 0.39" Bright Red LED, 7 Segment Lower Readout : 4 digits, 0.3" Luminous Green LED, 7 Segment
Digital Readout 96 X 96	Upper Readout : 4 digits, 0.56" Bright Red LED, 7 Segment Lower Readout : 4 digits, 0.56" Luminous Green LED, 7 Segment
Status Indicators	2 Red LEDs (3mm Round)
Keys	
Type	4 Tactile Switches
Functions	PAGE, DOWN, UP, ENTER
Sensor / Signal Input	
Type (User Programmable)	Thermocouple : J, K, T, R, S, B, N RTD Pt100, 3 wire DC Linear : 0-20 mA, 4-20 mA 0-50 mV, 0-200 mV 0-1.25 V, 0-5 V, 0-10 V, 1-5 V
Corrections	<ul style="list-style-type: none"> • In-built Cold-Junction Compensation for Thermocouples • In-built Lead Resistance Compensation for RTD (Upto 22 Ohms in each lead)
Accuracy	For Thermocouples & RTD : ± 0.25% of reading ± 1°C For DC Linear Volts / Current : ± 0.25% of reading ± 1 LSD

Display Range	Refer Table 1 for Thermocouples & RTD Inputs Adjustable from -1999 to 9999 Counts for DC Linear mA/mV/V
Display Resolution (User Programmable)	For Thermocouples & RTD : 0.1 / 1°C For DC Linear Volts / Current : 0.001 / 0.01 / 0.1 / 1 Counts
Zero Offset	User Adjustable over Full Range
ADC	16 Bit ($\pm 32,768$ Counts), Sigma-Delta ($\Sigma\Delta$)
Sampling Time	200mS (5 Samples per Second)
Input Resistance	> 8 MOhm
Common Mode Rejection	> 100dB at 50/60 Hz
Signal Conditioning	L-C Analog Filter with Programmable Digital Low-Pass Filter
Alarms	
Numbers	2, Independent
Programmable Parameters	Mode : Process Low, Process High Logic : Normal, Reverse Hysteresis : 1 to 3000 Unit Counts Inhibit : No, Yes Latch : No, Yes
Outputs (Optional)	Relay Change-over Contacts or SSR Drive (Jumper Selectable) Output-2 (OP-2) for Alarm-1, Output-3 (OP-3) for Alarm-2
Retransmission	
Signal Type (Output-1)	Standard : DC Current (0/4-20 mA) Optional : DC Volts (0-5/10 V)
PV Range	User Settable Through 'Range Low' and 'Range High' Parameters
Outputs	
Relay	Contact Type : Potential-free Change-over Contacts Contact Rating : 5A Resistive @ 120/240 Vac Contact Life : > 5,00,000 Operations at Rated Voltage / Current
SSR Drive	> 4.2 VDC into 1KOhm Minimum
DC Linear	Voltage : 0-5V, 0-10V (into 1KOhm Minimum) Current : 0-20mA, 4-20mA (into 500 Ohm Maximum)
Serial Communication	
Port	RS485, 2-wire, Half Duplex, Start-Stop Synchronized
Protocol	Modbus RTU
Baud Rate	Settable : 4800, 9600, 19200, 38400, 57600
Parity	Settable : None, Even, Odd
Max. Units per Loop	31
Max. Distance	1200 Meters

Power Supply	
Type	Switch Mode (SMPS)
Line Voltage	Standard : 85~264 VAC, 50/60Hz Optional : 18~36 VDC
Consumption	5VA Max
Physical	
Mounting	Plug-in with Panel Mounting Clamps
Overall Dimensions	48(H) X48(W) X 110(D), mm 96(H) X96(W) X 65(D), mm
Panel Cutout	45(H) X 45(W), mm 92(H) X 92(W), mm
Terminals	Screw Type
Weight	48 X 48 : 225 gm, Appx., 96 X 96 : 400 gm, Appx.
Environmental	
Operating Ambient	0~55°C & 5~90%RH Non-condensing
Storage Temperature	-10 to +70 °C
EMC Standards	EN50081-2 & EN 50082-2 Generic Stds for Industrial Environment
Safety Standards	Meets EN61010, Installation Catagory II
Atmospheres	Not Suitable for use in Corrosive or Explosive Atmospheres. The Panel in which the Instrument is Mounted must be free of Electrically Conductive Pollution.

Back Panel Terminations

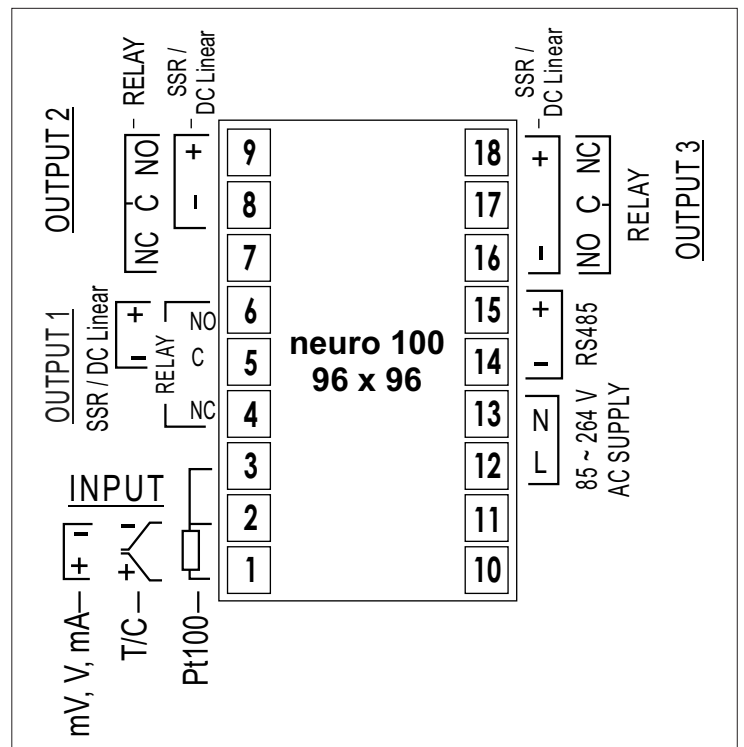
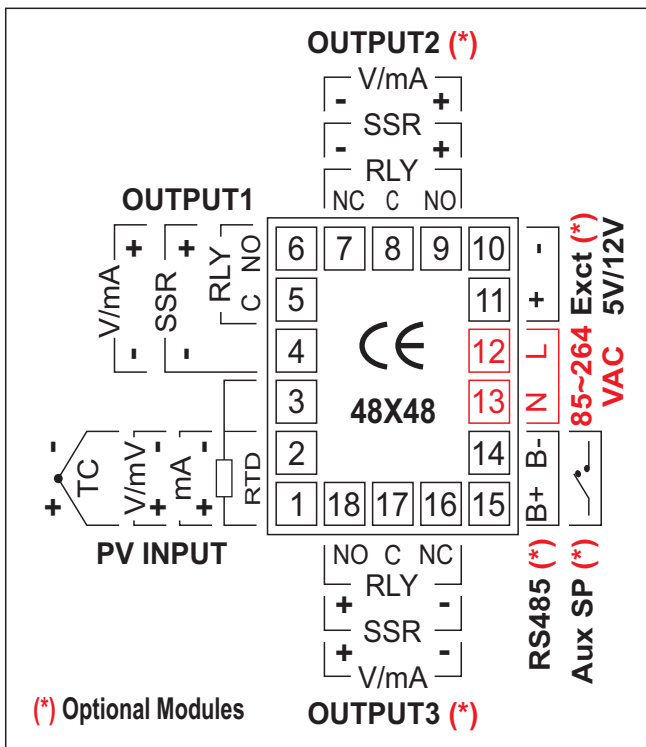

Table 1 : Temperature Ranges for Thermocouples & RTD

Input Type	Range (Min. to Max.)
Type J Thermocouple (Fe-K)	0 to +960°C / +32 to +1760°F
Type K Thermocouple (Cr-Al)	-200 to +1376°C / -328 to +2508°F
Type T Thermocouple (Cu-Con)	-200 to +385°C / -328 to +725°F
Type R Thermocouple (Pt/Pt-Rh13%)	0 to +1770°C / +32 to +3218°F
Type S Thermocouple (Pt/Pt-Rh10%)	0 to +1765°C / +32 to +3209°F
Type B Thermocouple	0 to +1825°C / +32 to +3092°F
Type N Thermocouple	0 to +1300°C / +32 to +2372°F
3-wire, RTD Pt100	-199 to +600°C / -328 to +1112°F or -199.9 to 600.0°C / -199.9 to 999.9°F

Ordering Code

Input*		Output 1		Output 2		Output 3		Power Supply		Excitation		Options		Size	
TC	Thermocouple	3	0-5/10V	0	None	0	None	0	85~264 VAC	0	None	N	None	48	48 X 48
PT	RTD Pt100	4	0/4-20 mA	1	Relay**	1	Relay**			5	5V @ 15mA	S	Serial Port	96	96 X 96
LV	Linear Voltage			2	SSR**	2	SSR**			12	12V @ 30mA				
LC	Linear Current														

* Input type is universal and requires appropriate jumper settings. The ordering code only implies the factory settings at the time of dispatch.

** Relay and SSR selection is jumper settable. The ordering code only implies the factory settings at the time of dispatch.

Example Code TC - 4 - 1 - 0 - 0 - 12 - S - 48

Thermocouple Input, Output-1 0/4-20 mA (Retransmission), Output-2 Relay, Output-3 None, 85~264 Vac Supply, 12 v Excitation, Serial Port, 48 x 48