

HumiTherm-cS



PPI

The Perfection Experts

Advanced 'Temperature + Humidity' Programmable Controller with Alarms



User Manual

CONTENTS

1. FRONT PANEL LAYOUT	1
2. BASIC OPERATION	3
3. SET-UP MODE : ACCESS & OPERATION	7
4. ALARM PARAMETERS	9
5. ON-OFF CONTROL PARAMETERS	11
6. INPUT CONFIGURATION PARAMETERS	14
7. SUPERVISORY PARAMETERS	16
8. RECORDER (RETRANSMISSION) PARAMETERS	18
9. COMPRESSOR SETTING PARAMETERS	19
10. HARDWARE ASSEMBLY & CONFIGURATIONS	23
10. MECHANICAL INSTALLATION	28
11. ELECTRICAL CONNECTIONS	30
APPENDIX-A : DC LINEAR SIGNAL INTERFACE	34
APPENDIX-B : PROCESS ALARMS	36

Section 1 FRONT PANEL LAYOUT

The Controller front panel comprises of digital readouts, LED indicators and membrane keys as shown in Figure 1.1 below.

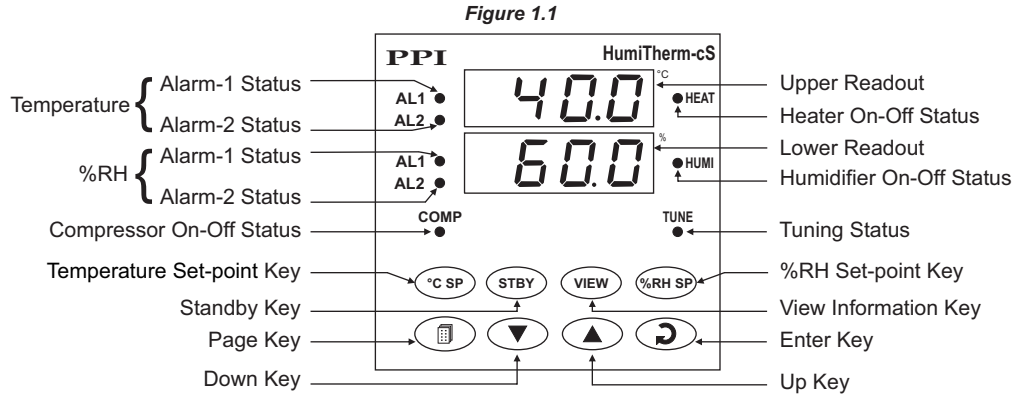

READOUTS

Upper Readout

This is a 4 digit, 7-segment bright red LED display and usually displays the Temperature Value in °C.

In Program Mode, the Upper Readout displays parameter values.

Lower Readout

This is a 4 digit, 7-segment bright green LED display and usually displays Relative Humidity (RH) Value in %. For Dry/Wet Configuration, upon holding UP or DOWN key depressed, the Lower Readout displays the Wet Bulb Temperature in °C.

In Program Mode, the Lower Readout displays prompts for the parameters.

INDICATORS

There are 8 front panel red LED indicators. These indicators show various statuses. The Table 1.1 below lists each LED indicator (identified by the front panel legend) and the associated status it indicates.









Table 1.1

Indicator	Function
AL1, AL2 (To the left of Upper Readout)	Temperature Alarm (Alarm-1 & Alarm-2) Status <ul style="list-style-type: none"> • Flashes while the Alarm is active • Remains OFF while the Alarm is inactive
AL1, AL2 (To the left of Lower Readout)	%RH Alarm (Alarm-1 & Alarm-2) Status <ul style="list-style-type: none"> • Flashes while the Alarm is active • Remains OFF while the Alarm is inactive
HEAT	Indicates control output status for Temperature
HUMI	Indicates control output status for %RH
COMP	Indicates control output status for Compressor
TUNE	Flashes if controller is Tuning Temperature and/or %RH Loops

KEYS

There are eight tactile keys provided on the front panel for configuring the controller and setting-up the parameter values. The Table 1.2 below lists each key (identified by the front panel symbol) and the associated function.

Table 1.2

Symbol	Key	Function
	PAGE	Press to enter or exit set-up mode.
	DOWN	Press to decrease the parameter value. Pressing once decreases the value by one count; keeping pressed speeds up the change.
	UP	Press to increase the parameter value. Pressing once increases the value by one count; keeping pressed speeds up the change.
	ENTER	Press to store the set parameter value and to scroll to the next parameter on the PAGE.
	Temp. Set-point Edit	Press to enter Set-up mode for Temperature Set-point.
	%RH Set-point Edit	Press to enter Set-up mode for %RH Set-point.
	Standby Mode	Press to enter/exit Standby operation mode.
	View Status	Press to view infrequently used process information like output control power and Wet Bulb SP.



Section 2 BASIC OPERATIONS

POWER-UP

Upon switching on the power to the controller, all displays and indicators are lit on for approximately 3 seconds during which time the controller runs through a self-test sequence. This is followed by the indication of the controller model name on the Upper Readout and the firmware version on the Lower Readout, for approximately 1 second.

MAIN DISPLAY MODE

Figure 2.1

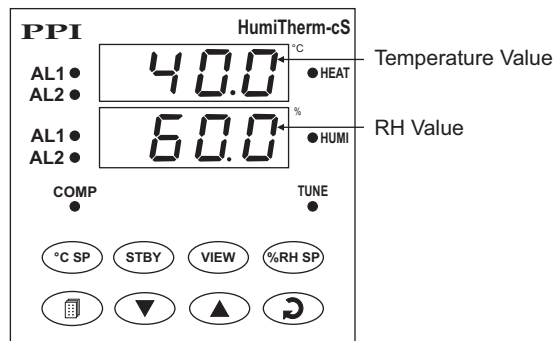

After the Power-up display sequence the controller enters into MAIN Display Mode. This is the default mode wherein the Upper Readout displays the measured Dry Bulb Temperature in °C and the Lower Readout displays the measured / computed Relative Humidity in %. If the controller is configured for Dry/Wet assembly, the Wet Bulb Temperature (in °C) can be viewed by holding the UP or DOWN key depressed. The MAIN Display Mode is depicted in Figure 2.1 above.

PV ERROR INDICATIONS

The controller flashes the PV error messages for Temperature and RH Values on Upper and Lower Readout, respectively.

- Error Indications for Dry-Bulb Temperature

In case of Dry-Bulb Temperature exceeding the specified Minimum or Maximum Range or in case of input sensor (RTD Pt100) open / broken; the Upper Readout flashes the Error Messages as listed in Table 2.1 below.

Table 2.1

Message	Error Type	Cause
Or	Over-range	Dry Bulb Temperature above Max. Range
Ur	Under-range	Dry Bulb Temperature below Min. Range
OPEN	Sensor Open	Dry Bulb Sensor (RTD) Broken / Open

- Error Indication for Relative Humidity (RH)

If RH transmitter is connected for direct %RH measurement, the signal output is either DC Voltage (e.g. 0 - 5 V, 1 - 3.3 V, etc.) or DC Current (e.g. 4 - 20 mA). Thus, an open or broken sensor means either 0 V or 0 mA output. In this case the controller reads the %RH that corresponds to this signal output. For example, consider 0-5V signal scaled to display 0.0 to 100.0 %RH. The Upper Readout then shows approximately 0.0 %RH (corresponding to 0 V) upon sensor open / broken.

If Dry/Wet assembly is used for RH measurement and if either Wet-Bulb RTD is open / broken or there is an error condition while computing %RH value, the Lower Readout flashes the Error Messages as listed in Table 2.2 below.

Table 2.2

Message	Error Type	Cause
	Over-range	Wet Bulb Temperature above Max. Range
	Under-range	Wet Bulb Temperature below Min. Range
	Sensor Open	Wet Bulb Sensor (RTD) Broken / Open
	RH Error	This error is indicated in the following cases : • Dry Bulb Temperature above 102.0°C. • Dry Bulb Temperature below -20.0°C. • Wet Bulb depression beyond: 50.0°C for Dry Bulb Temperature above 0°C 5.6°C for Dry Bulb Temperature below 0°C
	Display Freezes To 100.0%	This error is indicated in the following cases : • Wet-Bulb Temperature exceeds Dry-Bulb Temperature. • Computed % RH above 100.0%.
	Display Freezes To 0.0%	Computed % RH is below 0.0%.

Note:

For both Dry and Wet Bulb, 3-wire RTD sensor input, if the compensating lead is not connected or gets open, the controller does not indicate PV error but the measured value is not compensated for the lead resistance.

ALARM STATUS UNDER PV ERROR CONDITIONS

For Alarm activation, the *Under-range* condition is treated as minimum PV, whereas the *Over-range* and *Open* conditions are treated as maximum PV. Thus, Process High Alarm is activated upon *Over-range/Open* error. Similarly, Process Low Alarm is activated upon *Under-range* error. An *RH Error* condition activates Alarm associated with RH measurement.

ADJUSTING CONTROL/ALARM SET-POINTS

The two front panel keys, & , facilitate direct adjustments of control and alarm set-points for Temperature & RH channels respectively. Note that the values can be adjusted only if permitted at supervisory level. Also, the Alarm-1 & Alarm-2 set-points are *NOT* presented if the selected Alarm Type is 'None'.

The figure 2.2 below illustrates the adjustment procedure for Temperature Channel.

Figure 2.2

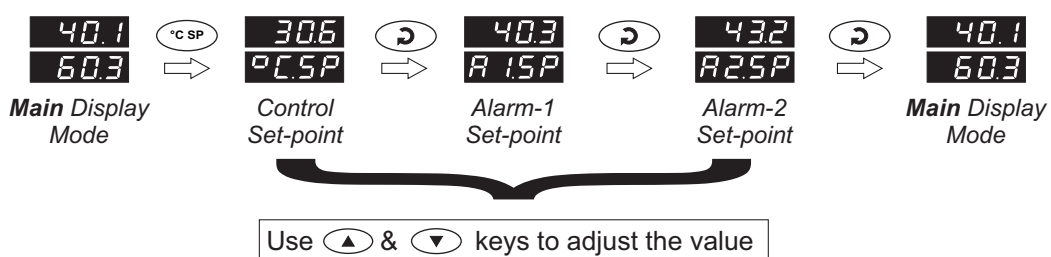

STANDBY MODE

In the normal operation mode the controller executes control for both temperature and %RH channels. The ‘Standby’ mode allows to disable (suppress) the control loop for one or both the channels. The disabled channel then behaves as an indicator wherein all the output Control signals and Alarm outputs are forced OFF. This feature allows the controller to be operated in one of the four modes by selecting the appropriate value for the standby parameter as shown in table 2.3 below.

Table 2.3

‘Standby’ Parameter Value	Channel(s) in Standby Mode	Controller Operation Mode
	None	None of the channels is in Standby Mode. The controller executes control loop for both Temperature & %RH.
	Both	Both the channels are in Standby Mode. The controller behaves as a Temperature + %RH indicator.
	Temperature	The Temperature channel is in Standby Mode. The controller executes control loop for %RH channel only. The Temperature channel behaves as an indicator.
	%RH	The %RH channel is in Standby Mode. The controller executes control loop for Temperature channel only. The %RH channel behaves as an indicator.

If enabled at supervisory level, the standby mode for one or both the channels can be activated and de-activated by pressing the front panel key. The Readouts for the channels in Standby mode continuously flash the measured values.

The figure 2.3 below illustrates how to select Temperature channel for standby mode.

Figure 2.3

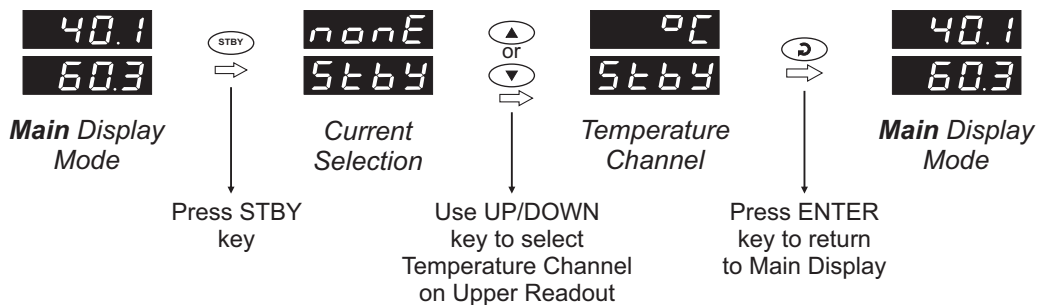

Notes:

1. The Standby and Tuning modes are mutually exclusive. If Tune command is issued while the Standby mode is active, the controller exits Standby mode and starts Tuning. Similarly, if Standby mode is activated while the controller is tuning, the controller aborts tuning operation and enters Standby mode.
2. If the Power Supply to the controller is switched-off or a Power-failure occurs while the controller is operating in Standby mode; upon resumption of power, the controller continues to operate in Standby mode.

VIEW CONTROL RELATED INFORMATION

The controller facilitates viewing the following control related values.

1. *Wet Bulb Set-point*

This information is available for 'Dry-Wet Configuration' only. The Wet Bulb Set-point is computed based on the Dry Bulb and %RH set-point values.

2. *Output Power for Temperature Control Loop*

This information is available for PID control loop only and indicate the heating output power in %

3. *Output Power for %RH Control Loop*

This information is available for PID control loop only and indicate the humidification output power in %.

Use the front panel  key to view the aforesaid information as illustrated in the figure 2.4 below.

Figure 2.4



Section 3

SET-UP MODE : ACCESS AND OPERATION

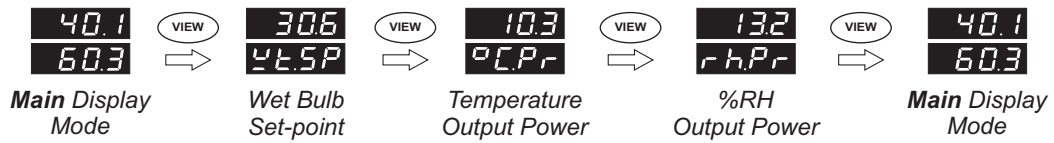
The various parameters are arranged in different groups depending upon the functions they represent. Each such group is called a PAGE and is assigned a unique numeric value, called PAGE NUMBER, for its access.

The parameters are always presented in a fixed format: The Lower Readout displays the parameter prompt (Identification Name) and the Upper Readout displays the set value. The parameters appear in the same sequence as listed in their respective sections.

SET-UP MODE

The Set-up Mode allows the user to view and modify the parameter values. Follow the steps below for setting the parameter values:

1. Press and release PAGE key. The Lower Readout shows `PAGE` and the Upper Readout shows page number `0` (0). Refer Figure 3.1.
2. Use UP / DOWN keys to set the desired PAGE NUMBER.
3. Press and release ENTER key. The Lower Readout shows the prompt for the first parameter listed in the set PAGE and the Upper Readout shows its current value. If the entered PAGE NUMBER is invalid (contains no parameter list or any associated function), the controller reverts to the MAIN Display Mode.
4. Press and release the ENTER key until the prompt for the required parameter appears on the Lower Readout. (The last parameter in the list rolls back to the first parameter).
5. Use UP / DOWN keys to adjust the parameter value. (The display flashes if UP key is pressed after reaching the maximum value or DOWN key is pressed after reaching the minimum value).
6. Press and release the ENTER key. The new value gets stored in the controller's non-volatile memory and the next parameter in the list is displayed.

The Figure 3.1 illustrates the example of altering the value for the parameter 'Input Type for Temperature Channel'.

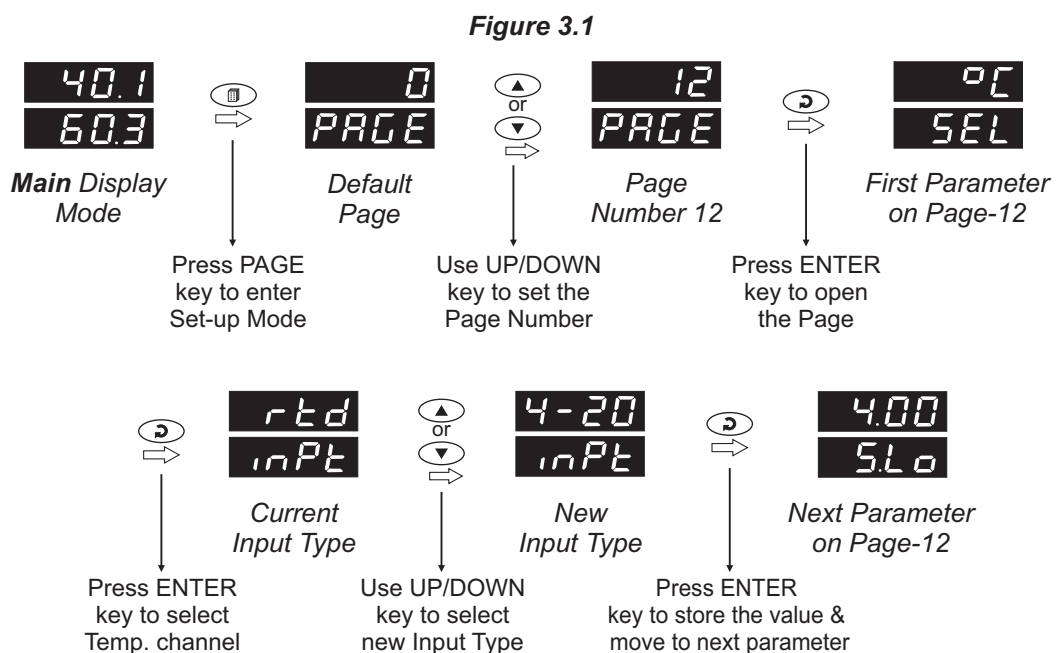

Notes

1. Each page contains a fixed list of parameters that are presented in a pre-determined sequence. Note however that availability of a few parameters, called Conditional Parameters, depend upon the settings for some other parameters. For example, the parameters 'Range Low' & 'Range High' are not available if the selected Input Type is RTD.
2. To exit the set-up mode and return to the MAIN Display Mode, press and release PAGE key.
3. If no key is pressed for approximately 30 seconds, the set-up mode times out and reverts to the MAIN Display Mode.

MASTER LOCKING

The controller facilitates locking all the PAGES by applying Master Lock Code. Under Locking, the parameters are available for *view only* and cannot be adjusted. The control & Alarm set-points and standby mode parameters are not locked by the Master Lock if the adjustments are permitted at supervisory level (page 13).

For enabling / disabling the Lock, step through the following sequence:

Locking

1. Press and release PAGE key while the controller is in the MAIN Display Mode. The Lower Readout shows **PAGE** (PAGE) and the Upper Readout shows **0** (0).
2. Use UP / DOWN keys to set the Page Number to 123 on the Upper Readout.
3. Press and release ENTER key. The controller returns to the MAIN Display Mode with the Lock enabled.

The Figure 3.2 below illustrates the Locking procedure.

Figure 3.2

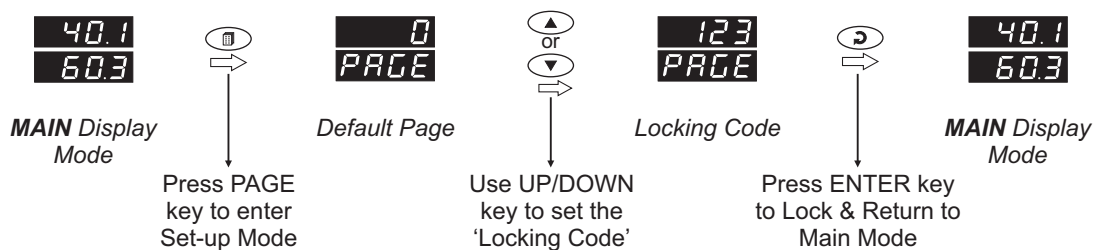

UnLocking

Repeat the Locking procedure twice for unlocking.



Section 4
PAGE-10 : ALARM PARAMETERS

The Alarm Parameters for both *Temperature* and *RH* are similar and grouped under their respective channel. To select and edit any parameters for *Temperature* or *RH*, first select the appropriate channel using the parameter 'SEL' (Select).

Refer Table 4.1 for parameter description and settings. [For details on Process Alarm refer Appendix - B.](#)

Table 4.1

Parameter Description	Settings (Default Value)
<p>SELECT CHANNEL SEL</p> <p>Select the Temperature or RH channel for viewing and/or editing the Alarm settings through the subsequent parameters.</p>	<div style="display: flex; flex-direction: column; align-items: flex-start;"> <div style="display: flex; align-items: center; margin-bottom: 5px;"> <div style="border: 1px solid black; padding: 2px; margin-right: 5px;">00</div> Temp </div> <div style="display: flex; align-items: center; margin-bottom: 5px;"> <div style="border: 1px solid black; padding: 2px; margin-right: 5px;">rh</div> Humidity </div> <p>(Default : Temp)</p> </div>
<p>ALARM 1 TYPE ALTY</p> <p><i>None</i> The Alarm function is disabled.</p> <p><i>Process Low</i> The Alarm is activated upon the Temperature/RH value equaling or falling below the 'Alarm Set-point' value.</p> <p><i>Process High</i> The Alarm is activated upon the Temperature/RH value equaling or rising above the 'Alarm Set-point' value.</p> <p><i>Deviation Band</i> In this case the 'Alarm Set-point' value sets a positive or negative deviation (offset) limit with respect to the 'Control Set-point'. The Alarm is activated upon the Temperature/RH value exceeding this deviation.</p> <p><i>Window Band</i> In this case the 'Alarm Set-point' value sets a positive and negative deviation (offset) limits with respect to the 'Control Set-point'. The Alarm is activated upon the Temperature/RH value exceeding this deviation.</p>	<div style="display: flex; flex-direction: column; align-items: flex-start;"> <div style="display: flex; align-items: center; margin-bottom: 5px;"> <div style="border: 1px solid black; padding: 2px; margin-right: 5px;">none</div> None </div> <div style="display: flex; align-items: center; margin-bottom: 5px;"> <div style="border: 1px solid black; padding: 2px; margin-right: 5px;">P_Lo</div> Process Low </div> <div style="display: flex; align-items: center; margin-bottom: 5px;"> <div style="border: 1px solid black; padding: 2px; margin-right: 5px;">P_Hi</div> Process High </div> <div style="display: flex; align-items: center; margin-bottom: 5px;"> <div style="border: 1px solid black; padding: 2px; margin-right: 5px;">dE</div> Deviation Band </div> <div style="display: flex; align-items: center;"> <div style="border: 1px solid black; padding: 2px; margin-right: 5px;">bAnd</div> Window Band </div> <p>(Default : None)</p> </div>
<p>ALARM-1 HYSTERESIS ALHY</p> <p>(Not Available if Alarm Type is None)</p> <p>This parameter sets a differential (dead) band between the ON and OFF Alarm status change. Keep it large enough to avoid frequent switching of the Alarm relay.</p>	<p style="text-align: center;">0.2 to 99.9 (Default : 2.0)</p>

Parameter Description	Settings (Default Value)
<p>ALARM-1 INHIBIT A 1, h</p> <p><i>(Not Available if Alarm Type is None)</i></p> <p>Yes The Alarm activation is suppressed until the Temperature/RH value is within Alarm limits from the time the controller is switched ON. This allows suppressing the Alarm during the start-up Alarm conditions.</p> <p>No The Alarm is not suppressed during the start-up Alarm conditions.</p>	<div style="text-align: right;"> <div style="border: 1px solid black; padding: 2px; display: inline-block;">no</div> No <div style="border: 1px solid black; padding: 2px; display: inline-block;">YES</div> Yes (Default : Yes) </div>
<p>ALARM 2 TYPE A2.tY</p> <p>ALARM-2 HYSTERESIS A2.HY</p> <p>ALARM-2 INHIBIT A2, h</p> <p><i>The parameter descriptions and settings are the same as that for Alarm-1.</i></p>	



Section 5
PAGE 11 : CONTROL PARAMETERS

The Control Parameters for both *Temperature* and *RH* are similar and grouped under their respective channel. To select and edit any parameters for *Temperature* or *RH*, first select the appropriate channel using the parameter 'SEL' (Select).

Refer Table 5.1 for parameter description and settings.

Table 5.1

Parameter Description	Settings (Default Value)
<p>SELECT CHANNEL SEL</p> <p>Select the Temperature or RH channel for viewing and/or editing the Control settings through the subsequent parameters.</p>	<div style="display: flex; flex-direction: column; align-items: flex-start;"> <div style="display: flex; align-items: center; margin-bottom: 5px;"> <div style="border: 1px solid black; padding: 2px; margin-right: 5px;">0C</div> Temp </div> <div style="display: flex; align-items: center; margin-bottom: 5px;"> <div style="border: 1px solid black; padding: 2px; margin-right: 5px;">rh</div> Humidity </div> <p>(Default : Temp)</p> </div>
<p>CONTROL ACTION C.Act</p> <p>Select appropriate Control Algorithm suited for process requirement.</p> <p><i>On-Off</i> The control algorithm tends to maintain the PV at SP by either switching the output fully OFF or fully ON. The On and Off switching is differentiated by the user settable 'Hysteresis'.</p> <p><i>PID</i> The control algorithm uses a 2nd order equation to compute the '% Output Power' required to maintain the PV at SP. The constants P, I, D are automatically set by the controller.</p>	<div style="display: flex; flex-direction: column; align-items: flex-start;"> <div style="display: flex; align-items: center; margin-bottom: 5px;"> <div style="border: 1px solid black; padding: 2px; margin-right: 5px;">On,Off</div> On-Off </div> <div style="display: flex; align-items: center; margin-bottom: 5px;"> <div style="border: 1px solid black; padding: 2px; margin-right: 5px;">PId</div> PID </div> <p>(Default : PID)</p> </div>
<p>SETPOINT LOW LIMIT SP.Lo</p> <p>Sets minimum permissible control setpoint value.</p>	<p>Input Type Minimum Range to Setpoint High Limit (Default : 0.0)</p>
<p>SETPOINT HIGH LIMIT SP.Hi</p> <p>Sets maximum permissible control setpoint value.</p>	<p>Setpoint Low Limit to Input Type Maximum Range (Default : 100.0)</p>
<p>HEAT/HUMIDIFICATION POWER LOW LIMIT PL <i>(Available for PID Control only)</i></p> <p>Sets the minimum % output power limit for Heat or Humidification.</p>	<p>0% to Power High Limit (Default : 0)</p>
<p>HEAT/HUMIDIFICATION POWER HIGH LIMIT PH <i>(Available for PID Control only)</i></p> <p>Sets the maximum % output power limit for Heat or Humidification.</p>	<p>Power Low Limit to 100% (Default : 100)</p>

Parameter Description	Settings (Default Value)
<p>PROPORTIONAL BAND (Cool Pre-dominant Zone) Pb.C</p> <p><i>(Available for AUTO mode with Dry Bulb SP Strategy with PID Control)</i></p> <p>Sets proportional gain (% output power per unit error). Defined in same units and resolution as that for measured Temperature or RH.</p> <p>Refer Section 9 for detailed description of Heat and Cool Pre-dominant Zones.</p>	<p>For Temp = 0.1 to 999.9°C For RH = 0.1 to 999.9% (Default : 50.0)</p>
<p>INTEGRAL TIME (Cool Pre-dominant Zone) It.C</p> <p><i>(Available for AUTO mode with Dry Bulb SP Strategy with PID Control)</i></p> <p>Sets integral time constant in Seconds. Setting the value to 0, cuts-off the integral action.</p> <p>Refer Section 9 for detailed description of Heat and Cool Pre-dominant Zones.</p>	<p>0 to 3600 Seconds (Default : 100 sec.)</p>
<p>DERIVATIVE TIME (Cool Pre-dominant Zone) dt.C</p> <p><i>(Available for AUTO mode with Dry Bulb SP Strategy with PID Control)</i></p> <p>Sets derivative time constant in seconds. Setting the value to 0, cuts-off the derivative action.</p> <p>Refer Section 9 for detailed description of Heat and Cool Pre-dominant Zones.</p>	<p>0 to 600 Seconds (Default : 16 sec.)</p>
<p>PROPORTIONAL BAND (Heat Pre-dominant Zone) Pb</p> <p><i>(Available for PID Control only)</i></p> <p>Sets proportional gain (% output power per unit error). Defined in same units and resolution as that for measured Temperature or RH.</p> <p>For AUTO mode with Dry Bulb SP Strategy, this value applied when Dry Bulb SP is in Heat Pre-dominant Zone. Refer Section 9 for detailed description of Heat and Cool Pre-dominant Zones.</p>	<p>For Temp = 0.1 to 999.9°C For RH = 0.1 to 999.9% (Default : 50.0)</p>
<p>INTEGRAL TIME (Heat Pre-dominant Zone) It</p> <p><i>(Available for PID Control only)</i></p> <p>Sets integral time constant in Seconds. Setting the value to 0, cuts-off the integral action.</p> <p>For AUTO mode with Dry Bulb SP Strategy, this value applied when Dry Bulb SP is in Heat Pre-dominant Zone. Refer Section 9 for detailed description of Heat and Cool Pre-dominant Zones.</p>	<p>0 to 3600 Seconds (Default : 100 sec.)</p>

Parameter Description	Settings (Default Value)
<p>DERIVATIVE TIME (Heat Pre-dominant Zone) dt</p> <p><i>(Available for PID Control only)</i></p> <p>Sets derivative time constant in seconds. Setting the value to 0, cuts-off the derivative action.</p> <p>For AUTO mode with Dry Bulb SP Strategy, this value applied when Dry Bulb SP is in Heat Pre-dominant Zone. Refer Section 9 for detailed description of Heat and Cool Pre-dominant Zones.</p>	<p>0 to 600 Seconds (Default : 16 sec.)</p>
<p>CYCLE TIME (Available for PID Control only) ct</p> <p>Sets the total 'On + Off' time in seconds for time proportional power output through Relay / SSR.</p>	<p>0.5 to 100.0 Seconds (in steps of 0.5 secs.) (Default : 10.0 sec.)</p>
<p>HYSTERESIS (Available for On-Off Control only) HYST</p> <p>Sets differential (dead) band between On-Off switching.</p>	<p>0.1 to 99.9 (Default : 2.0)</p>



Section 6

PAGE 12 : INPUT CONFIGURATION PARAMETERS

The Controller supports interface for both RTD Pt100 Sensors and DC Current / Voltage outputs from Temperature/RH Transmitters. The Parameters on this PAGE allows appropriate configuration for available input types for each channel (Temperature & RH). The parameters for both *Temperature* and *RH* input types are similar and grouped under their respective channel. To select and edit any parameters for *Temperature* or *RH*, first select the appropriate channel using the parameter 'SEL' (Select).

Refer Table 6.1 for parameter description and settings.

Table 6.1

Parameter Description	Settings (Default Value)																											
<p>SELECT CHANNEL SEL</p> <p>Select the Temperature or RH channel for Input Sensor configurations.</p>	<p>0C Temp</p> <p>rh Humidity</p> <p>(Default : Temp)</p>																											
<p>INPUT TYPE inPt</p> <p>Select Input type in accordance with the type of Temperature or RH sensor/transmitter connected for measurement.</p>	<p>Refer Table 6.2 (Default : For Temp. : RTD & For RH : 0 to 5.0)</p>																											
<p>SIGNAL LOW SLo</p> <p><i>(Available for DC linear mV/V/mA Inputs only)</i></p> <p>The transmitter output signal value corresponding to Range Low process value. Refer <i>Appendix-A : DC Linear Signal Interface</i> for details.</p>	<table border="1"> <thead> <tr> <th>Input Type</th> <th>Settings</th> <th>Default</th> </tr> </thead> <tbody> <tr> <td>0 to 20 mA</td> <td>0.00 to Signal High</td> <td>0.00</td> </tr> <tr> <td>4 to 20 mA</td> <td>4.00 to Signal High</td> <td>4.00</td> </tr> <tr> <td>0 to 50 mV</td> <td>0.00 to Signal High</td> <td>0.00</td> </tr> <tr> <td>0 to 200 mV</td> <td>0.0 to Signal High</td> <td>0.0</td> </tr> <tr> <td>0 to 1.25 V</td> <td>0.000 to Signal High</td> <td>0.000</td> </tr> <tr> <td>0 to 5 V</td> <td>0.000 to Signal High</td> <td>0.000</td> </tr> <tr> <td>0 to 10 V</td> <td>0.00 to Signal High</td> <td>0.00</td> </tr> <tr> <td>1 to 5 V</td> <td>1.000 to Signal High</td> <td>1.000</td> </tr> </tbody> </table>	Input Type	Settings	Default	0 to 20 mA	0.00 to Signal High	0.00	4 to 20 mA	4.00 to Signal High	4.00	0 to 50 mV	0.00 to Signal High	0.00	0 to 200 mV	0.0 to Signal High	0.0	0 to 1.25 V	0.000 to Signal High	0.000	0 to 5 V	0.000 to Signal High	0.000	0 to 10 V	0.00 to Signal High	0.00	1 to 5 V	1.000 to Signal High	1.000
Input Type	Settings	Default																										
0 to 20 mA	0.00 to Signal High	0.00																										
4 to 20 mA	4.00 to Signal High	4.00																										
0 to 50 mV	0.00 to Signal High	0.00																										
0 to 200 mV	0.0 to Signal High	0.0																										
0 to 1.25 V	0.000 to Signal High	0.000																										
0 to 5 V	0.000 to Signal High	0.000																										
0 to 10 V	0.00 to Signal High	0.00																										
1 to 5 V	1.000 to Signal High	1.000																										
<p>SIGNAL HIGH SHI</p> <p><i>(Available for DC linear mV/V/mA Inputs only)</i></p> <p>The transmitter output signal value corresponding to Range High process value. Refer <i>Appendix-A : DC Linear Signal Interface</i> for details.</p>	<table border="1"> <thead> <tr> <th>Input Type</th> <th>Settings</th> <th>Default</th> </tr> </thead> <tbody> <tr> <td>0 to 20 mA</td> <td>Signal Low to 20.00</td> <td>20.00</td> </tr> <tr> <td>4 to 20 mA</td> <td>Signal Low to 20.00</td> <td>20.00</td> </tr> <tr> <td>0 to 50 mV</td> <td>Signal Low to 50.00</td> <td>50.00</td> </tr> <tr> <td>0 to 200 mV</td> <td>Signal Low to 200.0</td> <td>200.0</td> </tr> <tr> <td>0 to 1.25 V</td> <td>Signal Low to 1.250</td> <td>1.250</td> </tr> <tr> <td>0 to 5 V</td> <td>Signal Low to 5.000</td> <td>5.000</td> </tr> <tr> <td>0 to 10 V</td> <td>Signal Low to 10.00</td> <td>10.00</td> </tr> <tr> <td>1 to 5 V</td> <td>Signal Low to 5.000</td> <td>5.000</td> </tr> </tbody> </table>	Input Type	Settings	Default	0 to 20 mA	Signal Low to 20.00	20.00	4 to 20 mA	Signal Low to 20.00	20.00	0 to 50 mV	Signal Low to 50.00	50.00	0 to 200 mV	Signal Low to 200.0	200.0	0 to 1.25 V	Signal Low to 1.250	1.250	0 to 5 V	Signal Low to 5.000	5.000	0 to 10 V	Signal Low to 10.00	10.00	1 to 5 V	Signal Low to 5.000	5.000
Input Type	Settings	Default																										
0 to 20 mA	Signal Low to 20.00	20.00																										
4 to 20 mA	Signal Low to 20.00	20.00																										
0 to 50 mV	Signal Low to 50.00	50.00																										
0 to 200 mV	Signal Low to 200.0	200.0																										
0 to 1.25 V	Signal Low to 1.250	1.250																										
0 to 5 V	Signal Low to 5.000	5.000																										
0 to 10 V	Signal Low to 10.00	10.00																										
1 to 5 V	Signal Low to 5.000	5.000																										
<p>RANGE LOW r.Lo</p> <p><i>(Available for DC linear mV/V/mA Inputs only)</i></p> <p>The process value corresponding to the Signal Low value from the transmitter. Refer <i>Appendix-A : DC Linear Signal Interface</i> for details.</p>	<p>-199.9 to 999.9 (Default : 0.0)</p>																											

Parameter Description	Settings (Default Value)
<p>RANGE HIGH r.H i</p> <p><i>(Available for DC linear mV/V/mA Inputs only)</i></p> <p>The process value corresponding to the Signal High value from the transmitter. Refer <i>Appendix-A : DC Linear Signal Interface</i> for details.</p>	<p>-199.9 to 999.9 (Default : 100.0)</p>
<p>OFFSET OFFSEt</p> <p>This value is algebraically added to the measured Temperature / RH Value to derive the final Value that is displayed and compared for alarm / control. Use this value to nullify any known constant error.</p> <p>Final Value = Measured Value + Offset</p> <p>Note : For Dry/Wet Configuration, the offset value for RH channel applies in °C to Wet RTD and not to computed %RH.</p>	<p>-50.0 to 50.0 (Default : 0.0)</p>

Table 6.2

Option	What it means	Range (Min. to Max.)	Resolution
rtd	3-wire, RTD Pt100	-199.9 to +600.0°C	0.1 °C
0-20	0 to 20mA DC current	-199.9 to 999.9 units	0.1 units
4-20	4 to 20mA DC current		
0.050	0 to 50mV DC voltage		
0.200	0 to 200mV DC voltage		
1.25	0 to 1.25V DC voltage		
5.0	0 to 5.0V DC voltage		
10.0	0 to 10.0V DC voltage		
1-5	1 to 5.0V DC voltage		





Section 7

PAGE 13 : SUPERVISORY PARAMETERS

The supervisory level responsibilities include exercising control over operator, making process related decisions and controlling the availability of process data for remote use.

The Table 7.1 below list supervisory parameters.

Table 7.1

Parameter Description	Settings (Default Value)
<p>TUNE COMMAND TUNE</p> <p>Set 'Yes' to activate and 'No' to abort the Tuning operation.</p>	<p>no No YES Yes (Default : No)</p>
<p>STANDBY FUNCTION STBY</p> <p><u>Enable</u> Allow Standby mode activation through front panel  key.</p> <p><u>Disable</u>  Key operation is disabled.</p>	<p>dSbL Disable EnbL Enable (Default : Disable)</p>
<p>CONTROL/ALARM SET-POINT ADJUSTMENT PERMISSION SP.OP</p> <p>Supervisory permission for Control & Alarm set-point adjustments for Temperature & RH channels. Set to 'Enable' for permission.</p>	<p>dSbL Disable EnbL Enable (Default : Disable)</p>
<p>DIGITAL INPUT FUNCTION d IFC</p> <p>This Input Function has been configured for Water Level detection and Alarm Acknowledgment.</p>	<p>nonE None LLoY Water Level R.AcY Alarm Ack. (Default : None)</p>
<p>WATER LEVEL LOGIC Y.LLo</p> <p><i>This parameter is visible once Water Level Function is selected in the Digital Input Function.</i></p> <p><i>Close : Water Level Low</i> The water level is considered <i>Low</i> if the switch is CLOSE.</p> <p><i>Open : Water level Low</i> The water level is considered <i>Low</i> if the switch is OPEN.</p>	<p>OPEn Open CLoS Close (Default : Open as Low)</p>

Parameter Description	Settings (Default Value)
<p>BAUD RATE bAud</p> <p>(Applicable for Serial Communication)</p> <p>This parameter sets communication speed in 'Bits per Second'. Set the value to match with the host baud rate.</p>	<div style="display: flex; flex-direction: column; align-items: flex-start;"> <div style="margin-bottom: 5px;">4.8 4800</div> <div style="margin-bottom: 5px;">9.6 9600</div> <div style="margin-bottom: 5px;">19.2 19200</div> <div style="margin-bottom: 5px;">38.4 38400</div> <div style="margin-bottom: 5px;">57.6 57600</div> <p>(Default : 9600)</p> </div>
<p>PARITY PAR ,</p> <p>(Applicable for Serial Communication)</p> <p>One of the communication error trapping features. Select the data packet parity as implemented by the host protocol.</p>	<div style="display: flex; flex-direction: column; align-items: flex-start;"> <div style="margin-bottom: 5px;">nonE None</div> <div style="margin-bottom: 5px;">EuEn Even</div> <div style="margin-bottom: 5px;">Odd Odd</div> <p>(Default : Even)</p> </div>
<p>DEVICE SLAVE ID id</p> <p>(Applicable for Serial Communication)</p> <p>Unique numeric code assigned to the controller for identification by the host. Set the value as required by the host.</p>	<p style="text-align: center;">1 to 127 (Default : 1)</p>
<p>SERIAL WRITE PERMISSION CoñE</p> <p>(Applicable for Serial Communication)</p> <p>Setting to 'No' disallows the host to set / modify any parameter values. The host, however, can read the values.</p>	<div style="display: flex; flex-direction: column; align-items: flex-start;"> <div style="margin-bottom: 5px;">no No</div> <div style="margin-bottom: 5px;">YES Yes</div> <p>(Default : No)</p> </div>



Section 8

PAGE 15 : RECORDER (RETRANSMISSION) PARAMETERS

The recorder parameters include selecting the signal output type and the Temperature/RH Range. The parameters for both *Temperature* and *RH* recorder are similar and grouped under their respective channel. To select and edit any parameters for *Temperature* or *RH*, first select the appropriate channel using the parameter 'SEL' (Select).

Refer Table 8.1 for parameter description & settings.

Table 8.1

Parameter Description	Settings (Default Value)
<p>SELECT CHANNEL SEL</p> <p>Select the Temperature or RH channel for setting the respective recorder parameters.</p>	<p>00 Temp</p> <p>RH Humidity</p> <p>(Default : Temp)</p>
<p>RECORDER OUTPUT TYPE REC0</p> <p>Select type in accordance with the hardware module fitted.</p> <p>Select 0-20 or 4-20 mA, if Current output module is fitted. Select 0-5 or 0-10 V, if Voltage output module is fitted.</p>	<p>0-20 0 - 20 mA</p> <p>4-20 4 - 20 mA</p> <p>0-5 0 - 5 V</p> <p>0-10 0 - 10 V</p> <p>(Default : 4 - 20 mA)</p>
<p>RECORDER LOW RECL</p> <p>Set the Low-side Temperature/RH Value that shall correspond to the minimum recorder output signal level (0 mA / 4 mA / 0 V).</p>	<p>Input Type Minimum Range to Input Type Maximum Range</p> <p>(Default : 0.0)</p>
<p>RECORDER HIGH RECH</p> <p>Set the High-side Temperature/RH Value that shall correspond to the maximum recorder output signal level (20 mA / 10 V / 5 V).</p>	<p>Input Type Minimum Range to Input Type Maximum Range</p> <p>(Default : 100.0)</p>



Section 9

PAGE 17 : COMPRESSOR SETTING PARAMETERS

Compressor Switching Strategies

The PPI “Temperature + Humidity” composite controllers offer different programmable strategies for compressor switching to meet different design approaches by the manufacturers of Humidity Chambers. The various strategies and the implementations are described here.

Manual Switching Mode

The compressor can be manually set to remain ON or OFF depending upon the desired temperature and RH values to be maintained inside chambers. Usually, for the temperature values below or little above the ambient temperature, the compressor is kept ON. For temperature values well above ambient, the compressor is kept OFF.

Auto Switching Mode

In this mode, the controller automatically sets or switches the compressor ON or OFF depending upon the user set strategy and the associated parameter values.

1. Dry Bulb SP Strategy

In this strategy, the chamber temperature range is split in two zones by setting the parameter 'Boundary Set-point' (BSP). Refer Figure 9.1 below.

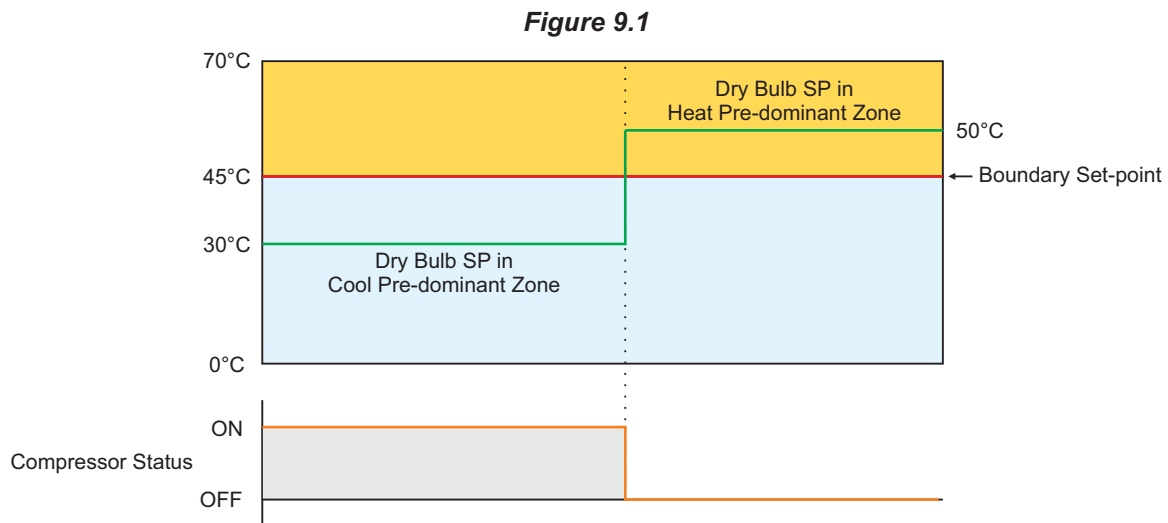

The zone at and above the boundary SP is referred as Heat Pre-dominant zone and that below the boundary SP is referred as Cool Pre-dominant zone. The controller automatically switches between the two zones depending upon the Dry Bulb (Temperature) SP. If the Dry Bulb (Temperature) SP is below boundary SP, Cool Pre-dominant zone is active and the compressor is kept ON. If the Dry Bulb (Temperature) SP is at or above boundary SP, Heat Pre-dominant zone is active and the compressor is kept OFF. This strategy eliminates the need for the user to manually switch the compressor ON or OFF.

Further, if the controller is programmed to run PID loops for Temperature and RH control; separate tuning can be performed in the Cool and Heat Pre-dominant zones for accurate control in each zone. The controller maintains separate sets of Proportional Band, Integral Time & Derivative Time constants for each zone that are automatically selected and used by the controller depending upon the active zone.

2. Dry Bulb PV Strategy

In this strategy, the compressor is switched to cool down the chamber air temperature. The controller switches the compressor ON or OFF based on the comparison between the chamber temperature value and the Dry Bulb SP. Refer Figure 9.2 below.

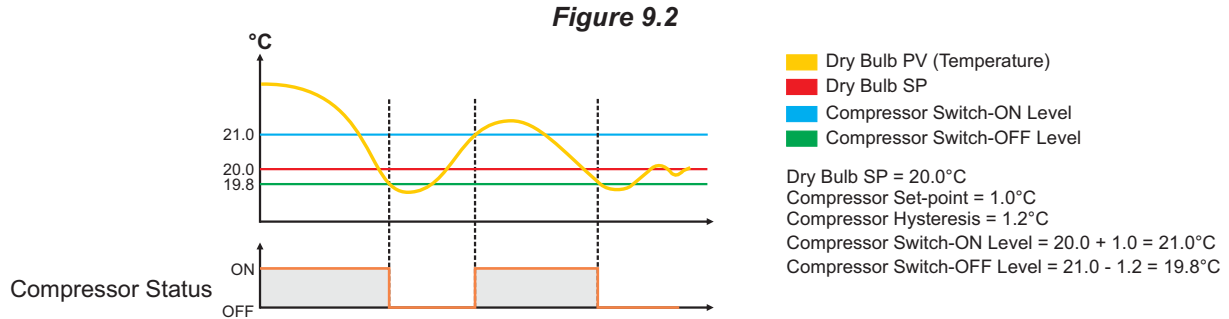

The compressor is turned ON if the chamber air temperature value is above the Dry Bulb SP by an amount set by the parameter 'Compressor Set-point'. That is;

$$\text{Compressor Switch - ON Level} = (\text{Dry Bulb SP}) + (\text{Compressor Set-point})$$

Once the air temperature falls below Compressor Switch-ON Level by an amount set by the parameter 'Compressor Hysteresis', the compressor is turned OFF. That is;

$$\text{Compressor Switch - OFF Level} = (\text{Compressor Switch-ON Level}) - (\text{Compressor Hysteresis})$$

The hysteresis inserts a dead band between the Compressor Switch-ON Level and Compressor Switch-OFF Level to avoid frequent switching of the compressor.

3. %RH PV Strategy

In this strategy, the compressor is switched to de-humidify the chamber air through condensation by cooling. The controller switches the compressor ON or OFF based on the comparison between the Relative Humidity (%RH) in the chamber air and the %RH Set-point. Refer Figure 9.3 below.

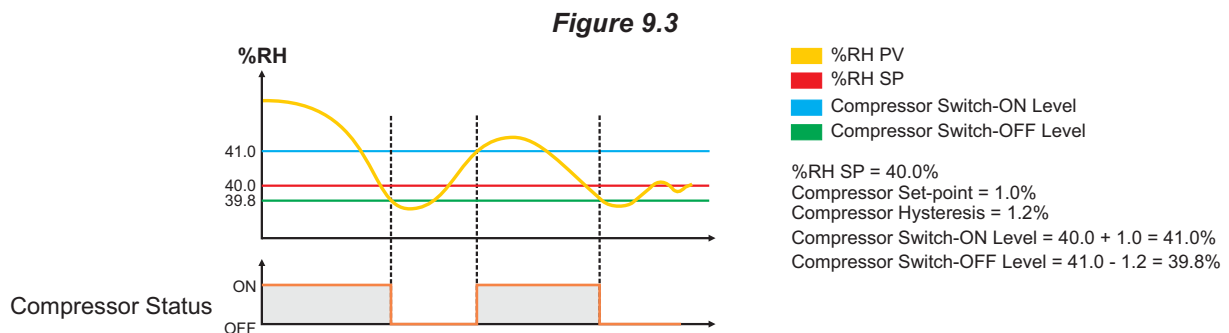

The compressor is turned ON if the %RH value is above the %RH SP by an amount set by the parameter 'Compressor Set-point'. That is;

$$\text{Compressor Switch - ON Level} = (\text{%RH SP}) + (\text{Compressor Set-point})$$

Once the %RH falls below Compressor Switch-ON Level by an amount set by the parameter 'Compressor Hysteresis', the compressor is turned OFF. That is;

$$\text{Compressor Switch - OFF Level} = (\text{Compressor Switch - ON Level}) - (\text{Compressor Hysteresis})$$

The hysteresis inserts a dead band between the Compressor Switch ON-Level and Compressor Switch-OFF Level to avoid frequent switching of the compressor.

Compressor Time Delay

Once the compressor is switched off, a time delay is desired before it is turned ON again. The time delay prevents the possible damage due to short cycling. When the compressor switches off, it spins backward as pressure equalizes. If compressor is energized while it is still spinning backward, it continues to run backward until it trips on internal overloads. This may cause damage to the compressor.

The time delay cycle is executed every time the compressor is turned off. The compressor turning off may be a result of power failure or the on-off control algorithm executed by the controller. The controller in “Auto Mode” monitors the Process Value (PV) against the Set-Point (SP) and attempts to switch the compressor ON or OFF depending upon whether the PV is above or below the SP.

The time delay starts counting down from the instance the compressor is switched off. The compressor is inhibited from switching-on until the delay elapses regardless of the difference between the PV and SP. Once the time delay is elapsed, the control algorithm switches the compressor ON as and when the PV is above SP.

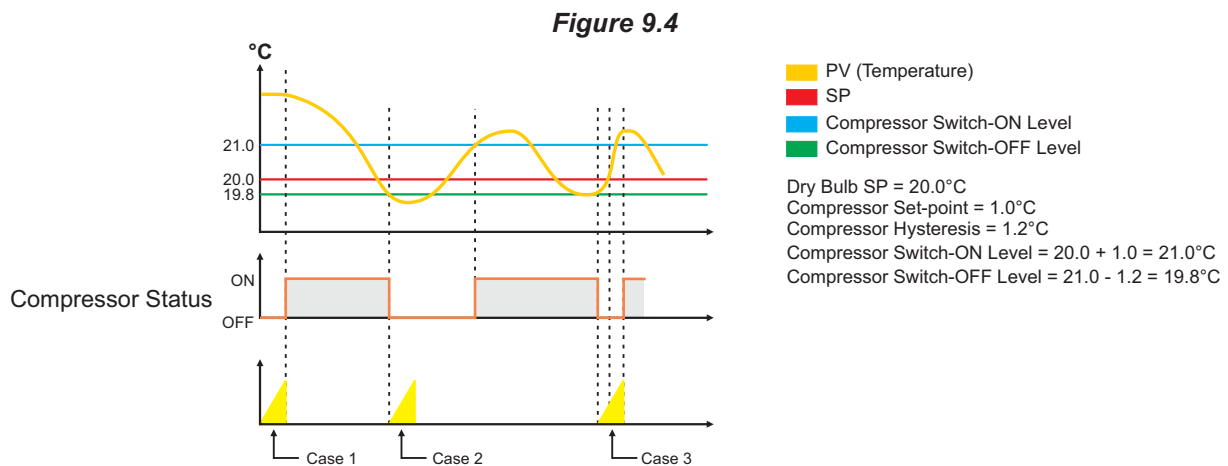

The figure 9.4 above illustrates 3 cases. Case (1) illustrates power-up delay. In case (2); the time elapses before PV rises above the SP. The compressor is thus switched ON as soon as the PV rises above the SP. In case (3); the PV rises above the SP while the time delay is still in progress. The compressor is switched ON as soon as the delay time elapses.

Table 9.1 lists various parameters required for setting-up appropriate compressor switching strategy and time delay.

Table 9.1

Parameter Description	Settings (Default Value)
<p>COMPRESSOR OUTPUT MODE CPDP</p> <p>This parameter allows to switch the compressor On-Off manually or activate AUTO mode to switch the compressor using the selected strategy through the parameter ‘Compressor Strategy’.</p> <p><u>Off</u> Compressor remains OFF regardless of PV or SP.</p> <p><u>On</u> Compressor remains ON regardless of PV or SP.</p> <p><u>Auto</u> Refer parameter ‘Compressor Strategy’.</p>	<p>OFF OFF</p> <p>On ON</p> <p>AUTO AUTO</p> <p>(Default : Auto)</p>

Parameter Description	Settings (Default Value)
<p>COMPRESSOR STRATEGY CPST <i>(Available for AUTO mode only)</i> Refer preceding description.</p>	<p>SP.PC Dry Bulb SP PW.PC Dry Bulb PV PURH %RH PV (Default : Dry Bulb SP)</p>
<p>BOUNDARY SET-POINT BSP <i>(Available for AUTO mode with Dry Bulb SP Strategy only)</i> Refer preceding description.</p>	<p>Temp. SP Low Limit to Temp. SP High Limit (Default : 45.0)</p>
<p>COMPRESSOR SET-POINT CPSP <i>(Available only for AUTO mode with Dry Bulb PV or %RH PV Strategy)</i> Refer preceding description.</p>	<p>0.0 to 50.0 (Default : 0.2)</p>
<p>COMPRESSOR HYSTERESIS CPHY <i>(Available only for AUTO mode with Dry Bulb PV or %RH PV Strategy)</i> Refer preceding description.</p>	<p>0.1 to 25.0 (Default : 0.2)</p>
<p>COMPRESSOR TIME DELAY CDLY This parameter sets a time interval that must elapse before the compressor can switch-on from the off state.</p>	<p>0.00 to 10.00 Min (in steps of 5 secs.) (Default : 0.00 Min)</p>



Figure 10.2

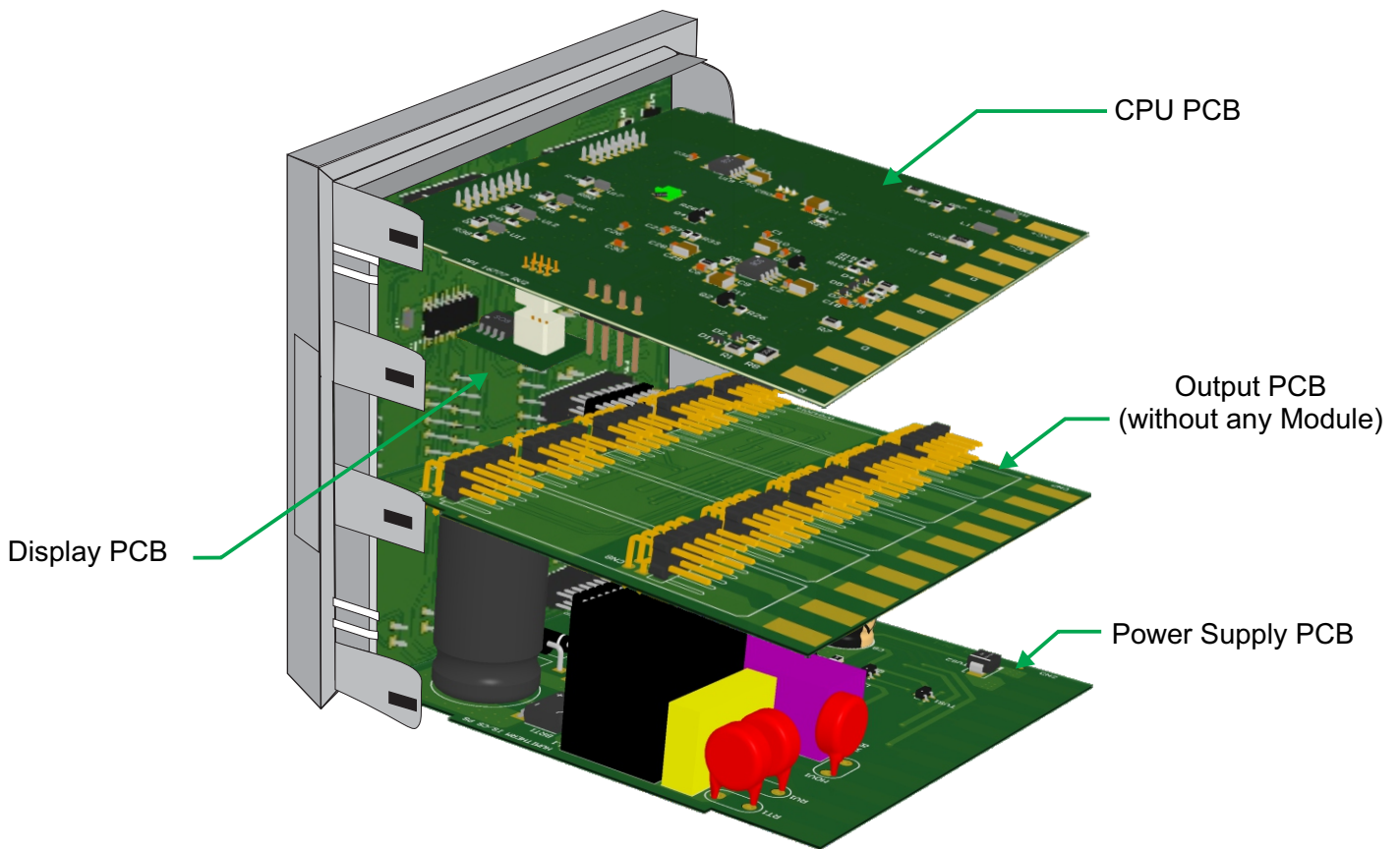

ELECTRONIC ASSEMBLY

The basic electronics assembly (without any plug-in modules), comprises of 4 Printed Circuit Boards (PCB). When viewed from the front; the CPU PCB is to the left, Power-supply PCB is to the right, Output PCB is in the center and the Display PCB is behind the bezel. Refer Figure 10.2.

Removing Assembly from Enclosure

Hold the Enclosure upside down and press the pullout latch to unlock the front bezel from the enclosure (Refer Figure 10.3). Pull the bezel outward. The electronics assembly comes out with the bezel.

Placing Assembly Back into Enclosure

Hold the Enclosure and the Bezel such that the Latching Slot on the Enclosure and the Pullout Latch on the Bezel face upward (See Figure 10.3). Insert the bezel gently into the Enclosure Until the Bezel snap fits.

Figure 10.3

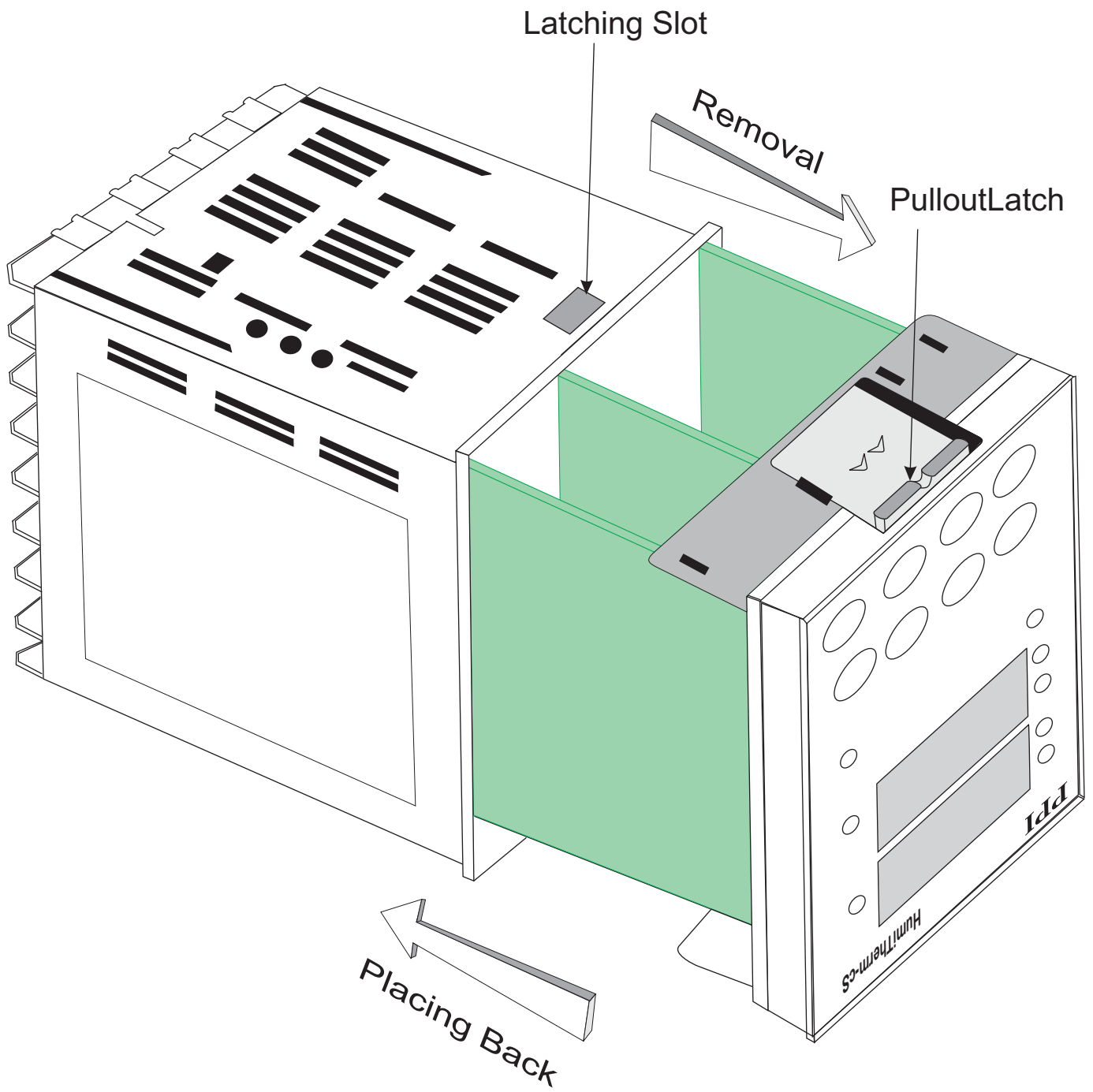

JUMPER SETTINGS FOR RELAY/SSR SELECTIONS

Figure 10.4

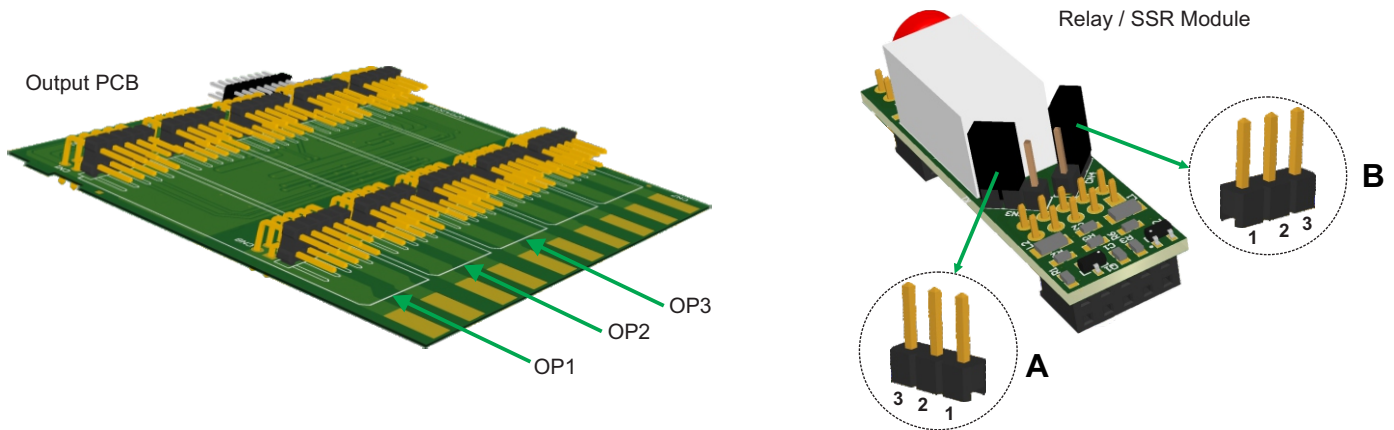

The Figure 10.4 shows the Output PCB & the Relay / SSR module. The Relay / SSR module is supported only on OP1, OP2 & OP3. The module can be configured to function as either Relay or SSR output by appropriate jumper settings 'A' & 'B' as shown in Figure 10.4 and Table 10.1 below. Use *Shorting - Link* for jumper settings. The 'Pins & Shorting-links' is illustrated in figure 10.5.

Table 10.1

Output Type	Jumper Setting - A	Jumper Setting - B
Relay		
SSR		

Figure 10.5

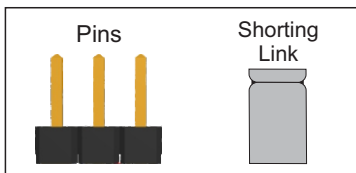

DC Linear Voltage / Current Module

The DC Linear Module, shown in Figure 10.6, is factory configured for either Current or Voltage output and is supported only on OP4 & OP5. The DC Current Module can be configured to output either 0-20 mA or 4-20 mA by appropriate parameter setting. Similarly, the DC Voltage Module can be configured to output either 0-5 V or 0-10 V by appropriate parameter settings.

Figure 10.6

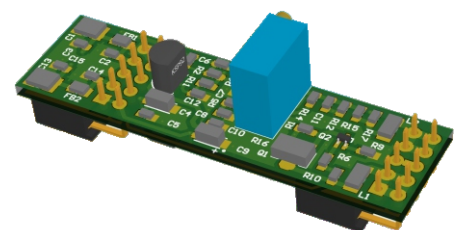

Serial Communication Plug-in Module

The 8-Pin miniature Male Plug for mounting the Serial Communication Module is located on the CPU PCB, as shown in the Figure 10.7 below. The Serial Communication Module is provided with a 8-Pin miniature female sockets on the bottom side for the mounting purpose. To plug (or unplug) the module simply insert (or remove) the socket into (or from) the plug.

Figure 10.7

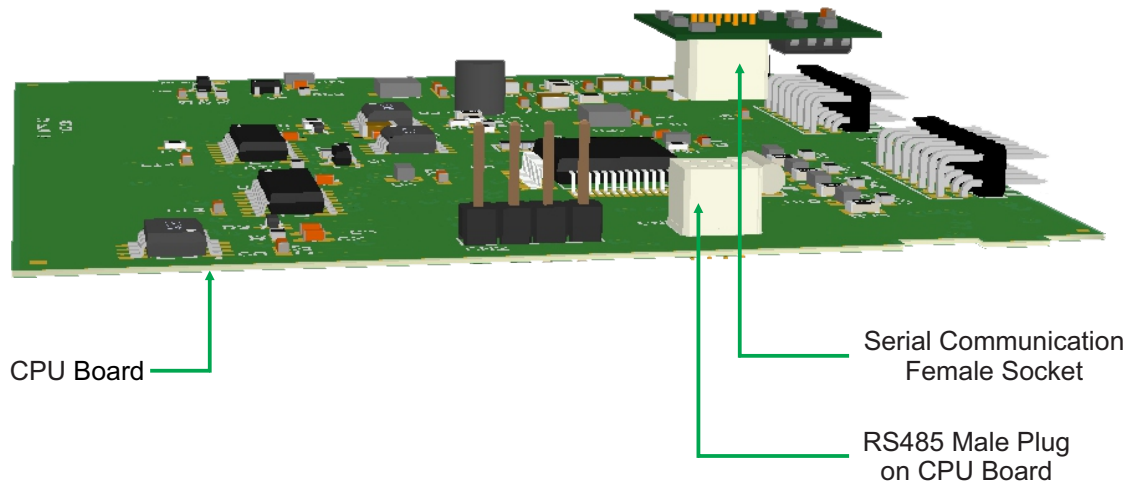

Section 11

MECHANICAL INSTALLATION

The following precautions should be strictly observed while installing the controller:

1. The place of installation should be free of corrosive/combustible gases and electrically conductive pollution.
2. Ensure that the place of installation is not subject to rapid ambient changes that can cause condensation. Also the Ambient Temperature and Relative Humidity surrounding the controller should not exceed the maximum specified for the proper operation of the controller.
3. The place of installation should be adequately protected against excessive electrostatic or electromagnetic interference.
4. The controller should not be subject to direct vibration or shock.
5. The controller should not be exposed to dust, salt air, direct sunlight or radiant heat.

OUTER DIMENSIONS

The Figure 11.1 shows the outer dimensions of the controller.

Figure 11.1

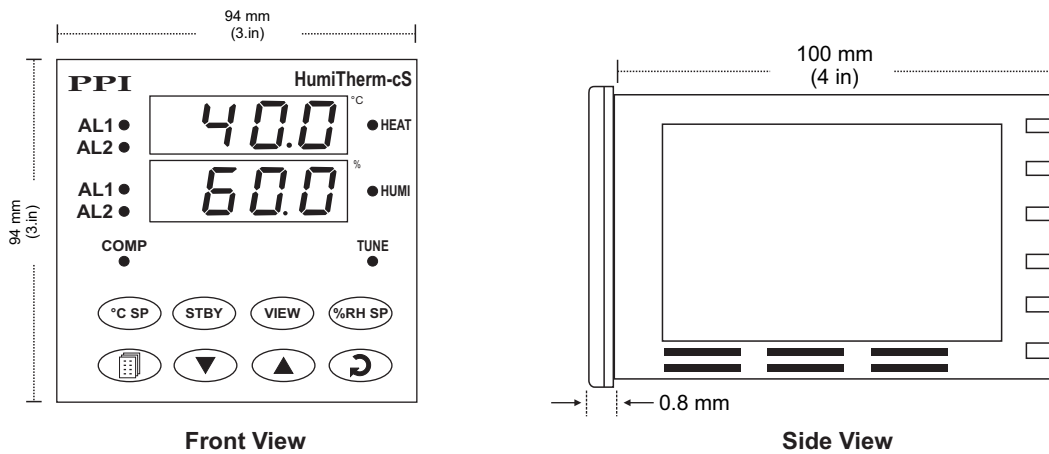

PANEL CUTOUT AND RECOMMENDED MINIMUM SPACING

The Figure 11.2 shows the panel cutout requirements for a single controller and also the minimum spacing recommended if several controllers are required to be mounted on a single panel.

Figure 11.2

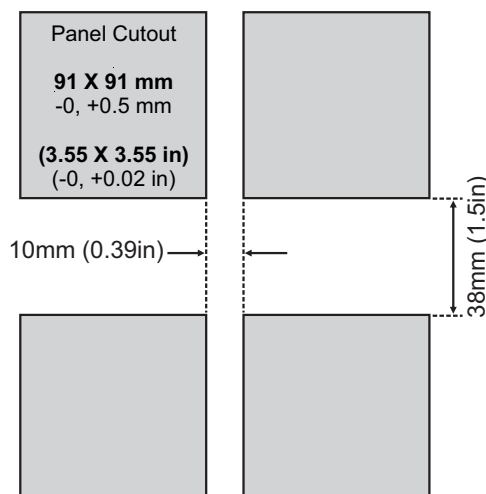

PANEL MOUNTING

Follow the steps below for mounting the controller on panel:

1. Prepare a square cutout to the size shown in Figure 11.2.
2. Remove the Mounting Clamps from the controller Enclosure.
3. Insert the rear of the controller housing through the panel cutout from the front of the mounting panel.
4. Hold the controller gently against the mounting panel such that it positions squarely against the panel wall, see Figure 11.3. Apply pressure only on the bezel and not on the front label.
5. Fix the Mounting Clamps (one after the other) such that the metallic projection fits in the square hole provided on the top and bottom sides of the enclosure. Tighten the clamp screw until the clamps firmly secures against the panel wall.

Figure 11.3

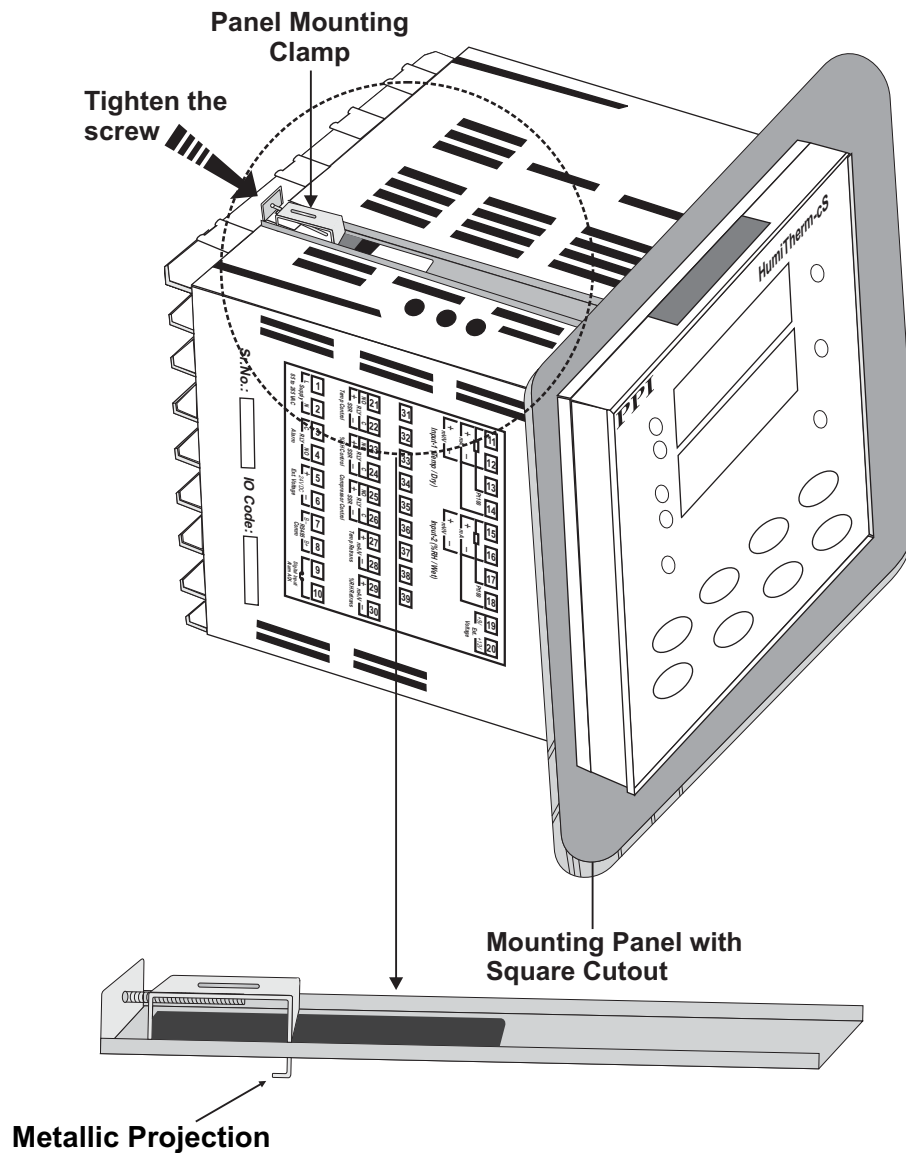

Section 12

ELECTRICAL CONNECTIONS

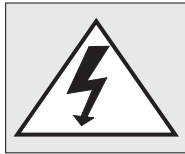

WARNING
MISHANDLING / NEGLIGENCE CAN RESULT IN PERSONAL DEATH OR SERIOUS INJURY.

1. The user must rigidly observe the Local Electrical Regulations.
2. Do not make any connections to the unused terminals for making a tie-point for other wires (or for any other reasons) as they may have some internal connections. Failing to observe this may result in permanent damage to the controller.
3. Run power supply cables separated from the low-level signal cables (like **RTD, DC** Linear Current/Voltage, etc.). If the cables are run through conduits, use separate conduits for power supply cable and low-level signal cables.
4. Use appropriate fuses and switches, wherever necessary, for driving the high voltage loads to protect the controller from any possible damage due to high voltage surges of extended duration or short-circuits on loads.
5. Take care not to over-tighten the terminal screws while making connections.
6. Make sure that the controller supply is switched-off while making/removing any connections or removing the controller from its enclosure.

CONNECTION DIAGRAM

The Electrical Connection Diagram is shown on the left side of the controller enclosure. The diagram shows the terminals viewed from the **REAR SIDE** with the controller label upright. The Connection Diagram is a generic one; the connections shown for optional modules are applicable only if the modules are fitted.

Figure 12.1

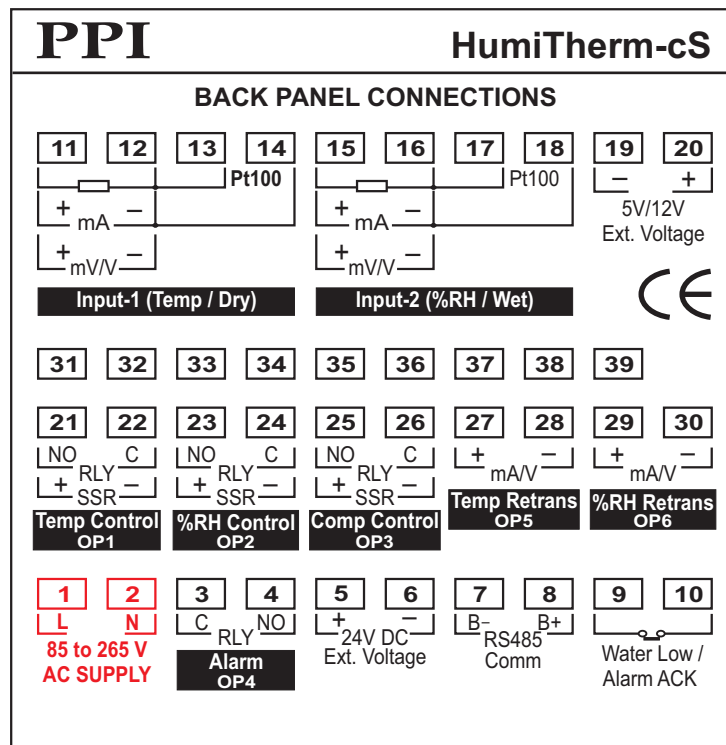

DESCRIPTIONS

The back panel connections are described as under:

INPUT-1 : Temp/Dry (Terminals : 11, 12, 13, 14)

INPUT-2 : RH/Wet (Terminals : 15, 16, 17, 18)

Both the inputs are designed to accept RTD (3-wire Pt100), DC Current (mA) and DC Voltage (mV/V). The connections for both the inputs are identical in all respects except their respective terminals and are described below.

RTD Pt100, 3-wire

Connect single leaded end of RTD bulb to terminal 11 (or 15) and the double leaded ends to terminals 12 & 13 (or 16 & 17) as shown in Figure 12.2.

Use copper conductor leads of very low resistance ensuring that all 3 leads are of the same gauge and length. Avoid joints in the cable.

Figure 12.2

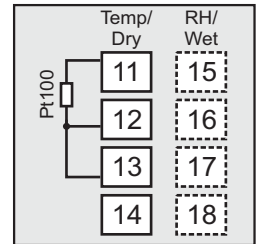

Figure 12.3 (a)

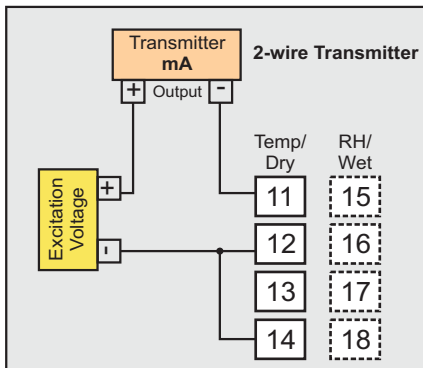
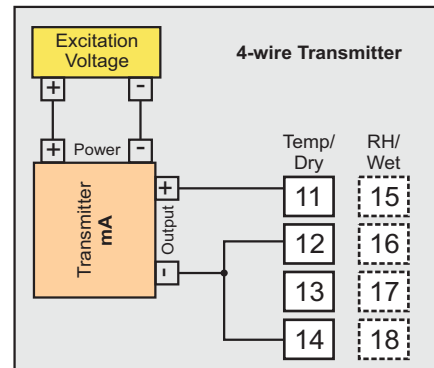

Figure 12.3 (b)



Transmitter with DC Current (mA) Output

The Figures 12.3 (a) & 12.3 (b) depict wiring connections for 2-wire & 4-wire current output transmitters respectively. The Excitation Voltage can be obtained from an external source or from the controller. Note that terminals 12 & 14 (or 16 & 18) should be shorted.

Transmitter with DC Voltage (mV or V) Output

The Figures 12.4 depicts wiring connections for voltage output transmitter. The Excitation Voltage can be obtained from an external source or from the controller.

Figure 12.4

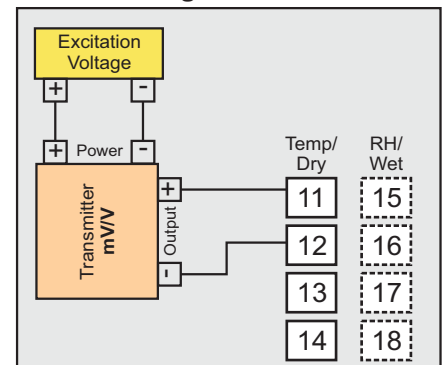

24 VDC EXCITATION VOLTAGE (Terminals : 5, 6)

This power source is primarily meant for exciting 2-wire or 4-wire current output transmitters. For connection details refer figure 12.3(a) & 12.3 (b). Ensure proper polarities for terminals labeled '+' & '-'.

5 VDC & 12 VDC EXCITATION VOLTAGES (Terminals : 19, 20)

These power sources are primarily meant for connecting 3-wire mV/V output transmitters. The Ground (Common) terminal is not provided separately as the '-' output terminal of the transmitter serves the dual purpose of signal return path and power source common.

TEMPERATURE RETRANSMISSION (RECORDER) OUTPUT (Terminals : 27, 28)

%RH RETRANSMISSION (RECORDER) OUTPUT (Terminals : 29, 30)

The retransmission output is either DC Current (0/4-20 mA) or DC Voltage (0-5/10 V) depending on the module fitted. The terminal labeled '+' & '-' are the Current/Voltage source output and return, respectively.

TEMPERATURE CONTROL OUTPUT (Terminals : 21, 22)

%RH CONTROL OUTPUT (Terminals : 23, 24)

COMPRESSOR CONTROL OUTPUT (Terminals : 25, 26)

ALARM OUTPUT (Terminals : 3, 4)

The Temperature Control, %RH Control and Compressor Control outputs are Relay/SSR jumper selectable whereas Alarm output is fixed Relay. The Relay and SSR output are described below.

Figure 12.5(a)

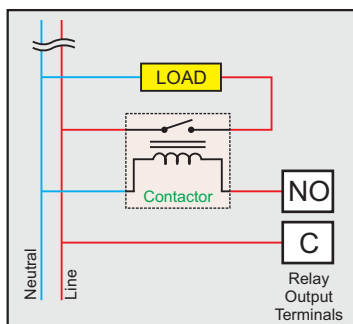
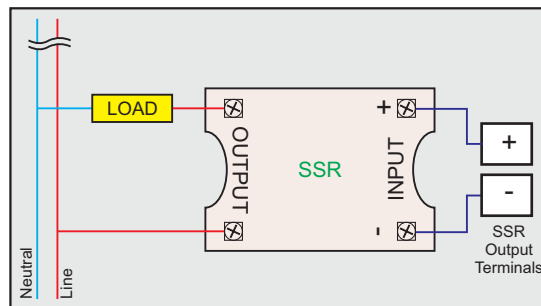

Figure 12.5(b)



Relay

Potential-free Change-over contacts NO (Normally Open) and C (Common) rated 2A/240 VAC (resistive load) are provided as Relay output. Use external auxiliary device like contactor with appropriate contact rating for driving the actual load.

The figure 12.5(a) depicts electrical wiring connections using Relay output and external contactor for driving load.

SSR (Solid State Relay)

DC Voltage level is generated for switching the external SSR. Use Zero-Crossover, 3 to 30 VDC operated SSR, rated approximately 1.5 times the actual load rating. Use appropriate Heat Sink for load rating exceeding 10A.

The figure 12.5(b) depicts electrical wiring connections using SSR output for driving load.

DIGITAL INPUT /ALARMACKNOWLEDGMENT (Terminals 9, 10)

Potential-free contact closure input terminals are provided for connecting a remote (external) button for the purpose of issuing an Alarm Acknowledgment command & also Digital Input for Water Level detection. An 'OPEN' to 'CLOSE' change-over of the contacts acts as an Acknowledgment command & also Digital Input for Water Level detection. Refer figure 12.6.

Figure 12.6

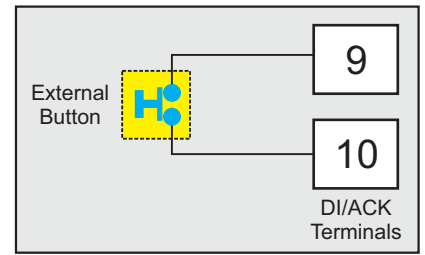

SERIAL COMMUNICATION PORT (Terminals 7 & 8)

Figure 12.7

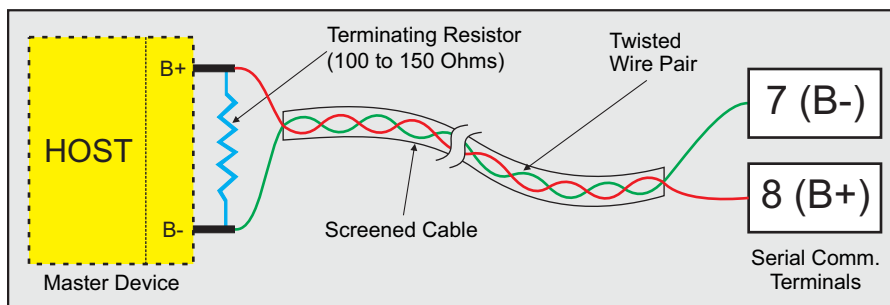

The controller Communication Port is RS485 and requires a similar port at the host (master) end. If, however, the host port is different (say, RS232), use appropriate protocol converter (say, RS485-RS232) for interface.

For reliable noise free communication, use a pair of twisted wires inside screened cable as shown in Figure 12.7. The wire should have less than 100 ohms / km nominal DC resistance (Typically 24 AWG or thicker). Connect the terminating resistor (Typically 100 to 150 ohm) at one end to improve noise immunity.

POWER SUPPLY (Terminals 1, 2)

Figure 12.8

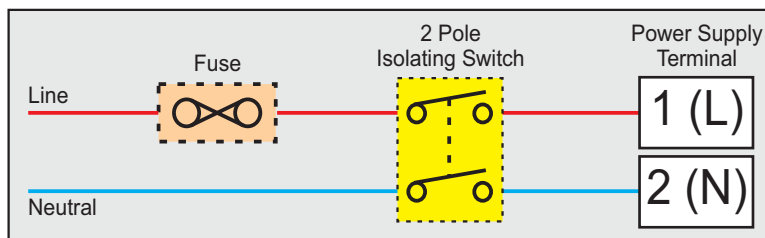

Caution

The controller is designed for installation in an enclosure which provides adequate protection against electric shock. Local regulations regarding electrical installation should be rigidly observed. Consideration should be given to prevention of access to the Power Supply terminals by unauthorized personnel.

As standard, the controller is supplied with power connections suited for 85 to 264 VAC line supply. Use well-insulated copper conductor wire of the size not smaller than 0.5mm² for power supply connections. Connect Line (Phase) supply line to terminal 1 and the Neutral (Return) supply line to terminal 2 as shown in Figure 12.8. The controller is not provided with fuse and power switch. If necessary, mount them separately. Use a time lag fuse rated 1A @ 240 VAC.



APPENDIX - A

DC LINEAR SIGNAL INTERFACE

This appendix describes the parameters required to interface process transmitters that produce Linear DC Voltage (mV/V) or Current (mA) signals in proportion to the measured process values. A few examples of such transmitters are;

1. Pressure Transmitter producing **4 to 20 mA** for **0 to 5 psi**
2. Relative Humidity Transmitter producing **1 to 4.5 V** for **5 to 95 %RH**
3. Temperature Transmitter producing **0 to 20 mA** for **-50 to 250 °C**

The instrument (indicator/controller/recorder) that accepts the linear signal from the transmitter computes the measured process value by solving the mathematical equation for Straight-Line in the form:

$$Y = mX + C$$

Where;

- X : Signal Value from Transmitter
- Y : Process Value Corresponding to Signal Value X
- C : Process Value Corresponding to X = 0 (Y-intercept)
- m : Change in Process Value per unit Change in Signal Value (Slope)

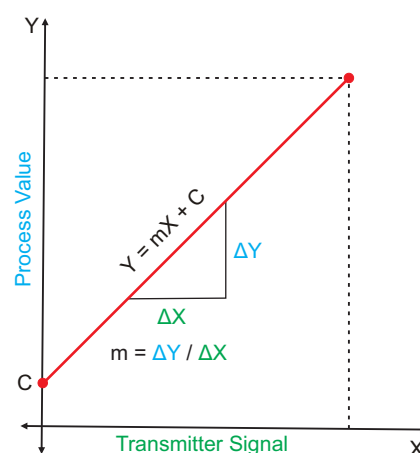

As is evident from the aforementioned transmitter examples, different transmitters produce signals varying both in type (mV/V/mA) and range. Most PPI instruments, thus, provide programmable Signal Type and Range to facilitate interface with a variety of transmitters. A few industry standard signal types and ranges offered by the PPI instruments are: 0-50mV, 0-200mV, 0-5 V, 1-5 V, 0-10V, 0-20 mA, 4-20 mA, etc.

Also, the output signal range (e.g. 1 to 4.5 V) from different transmitters corresponds to different process value range (e.g. 5 to 95 %RH); the instruments thus also provide facility for programming the measured process value range with programmable Resolution.

The linear transmitters usually specify two signal values (Signal Low and Signal High) and the corresponding Process Values (Range Low and Range High). In the example Pressure Transmitter above; the Signal Low, Signal High, Range Low & Range High values specified are: 4 mA, 20 mA, 0 psi & 5 psi, respectively.

In summary, the following 6 parameters are required for interfacing Linear Transmitters:

1. Input Type : Standard DC Signal Type in which the transmitter signal range fits (e.g. 4-20 mA)
2. Signal Low : Signal value corresponding to Range Low process value (e.g. 4 mA)
3. Signal High : Signal value corresponding to Range High process value (e.g. 20 mA)
4. PV Resolution : Resolution (least count) with which to compute process value (e.g. 0.01)
5. Range Low : Process value corresponding to Signal Low value (e.g. 0.00 psi)
6. Range High : Process value corresponding to Signal High value (e.g. 5.00 psi)

The following examples illustrate appropriate parameter value selections.

Example 1: Pressure Transmitter producing **4 to 20 mA** for **0 to 5 psi**

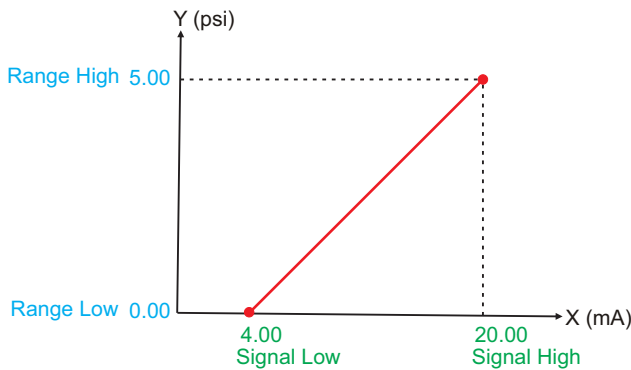

Presume the pressure is to be measured with 0.01 Resolution, that is 0.00 to 5.00 psi.

Input Type : 4-20 mA
 Signal Low : 4.00 mA
 Signal High : 20.00 mA
 PV Resolution : 0.01
 Range Low : 0.00
 Range High : 5.00

Example 2: Relative Humidity Transmitter producing **1 to 4.5 V** for **5 to 95 %RH**

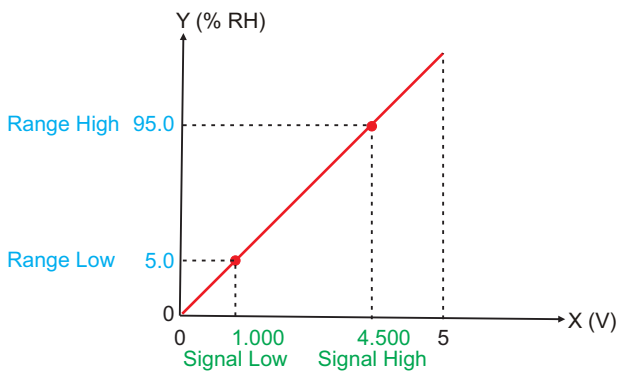

Presume the humidity is to be measured with 0.1 Resolution, that is 0.0 to 100.0 %.

Input Type : 0-5 V
 Signal Low : 1.000 V
 Signal High : 4.500 V
 PV Resolution : 0.1
 Range Low : 5.0
 Range High : 95.0

Example 3: Temperature Transmitter producing **0 to 20 mA** for **-50 to 250 °C**

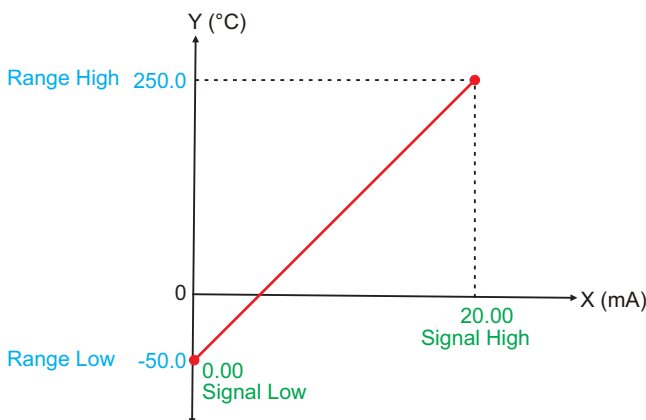

Presume the Temperature is to be measured with 0.1 Resolution, that is -50.0 to 250.0°C.

Input Type : 0-20 mA
 Signal Low : 0.00 mA
 Signal High : 20.00 mA
 PV Resolution : 0.1
 Range Low : -50.0
 Range High : 250.0



APPENDIX - B

PROCESS ALARMS

Definition & Purpose

The process alarm is an event generated and triggered by the process monitoring / controlling instrument in response to the process value deviation from a preset limit. The purpose is to alert the operator of an abnormal process behavior that could result in physical and economic loss. The process alarms are thus implemented to ensure normal and safe process operation.

The alarm system continuously monitors the process signal (such as one representing Temperature, Relative Humidity, Pressure or Flow) and compares it against preset limits (also called Set-points). If the process signal moves to undesirable high or low level, the alarm activates a relay output to warn of trouble, provide on-off control or institute an emergency shutdown.

Hysteresis

The Alarm relay triggers upon crossing the preset limit (set-point) and usually remains active until the process signal re-crosses the limit and passes out of a dead band called Hysteresis. The dead band is usually adjustable and determines at what point the alarm relay resets to its non-alarm state.

The hysteresis prevents the alarm relay from chattering on & off should the process signal oscillate up and down around the alarm limit, as shown in the figure B.1(a) and figure B.1(b) below.

Figure B.1 (a) : Alarm without Hysteresis

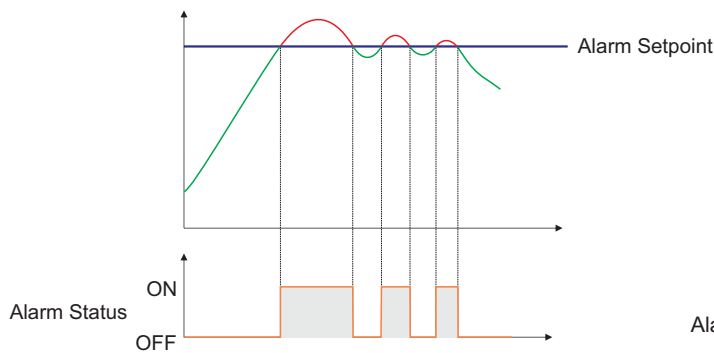
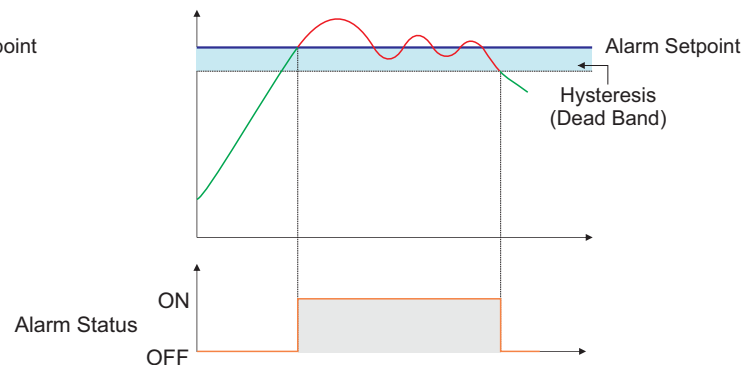

Figure B.1 (b) : Alarm with Hysteresis



Latched Alarm

If the alarm is programmed as Latched Alarm, the alarm relay cannot reset automatically upon removal of alarm condition. The relay latches in the alarm condition until manually reset by the operator by pressing “Acknowledge” button. The purpose of a latched alarm is to ensure that the occurrence of an alarm does not go unnoticed.

Direct / Reverse Relay Activation

If the alarm relay is programmed to operate Direct in response to the Alarm status, the relay switches ON upon alarm activation and switches OFF upon reset. The direct relay activation is used for triggering an audio/visual alert device like Siren, Hooter, Warning Light, Bell, etc., for attracting attention of the operator.

If the alarm relay is programmed to operate Reverse in response to the Alarm status, the relay switches OFF upon alarm activation. The relay activation in this case is used to shutdown the process power. Under non-alarm condition the relay remains ON to power to the process.

Alarm Inhibit

In many cases it is desired that the alarm system activates only once the process signal reaches / crosses the preset alarm set-point from a known condition such as process startup or change in set-point. The alarm inhibit feature can be enabled for this purpose.

The figure B.2 below depicts a heating system wherein the temperature is to be raised to 800°C and then to be monitored to remain within ±10°C. Upon cold start (Process Value near Ambient), the system temperature is obviously outside alarm band and will generate alarm if inhibit feature is not enabled.

The inhibit feature suppresses the alarm upon power-up until the process value rises above the Low Limit at 790°C. The alarm system is now activated and will trigger the alarm relay should the temperature deviate outside the band.

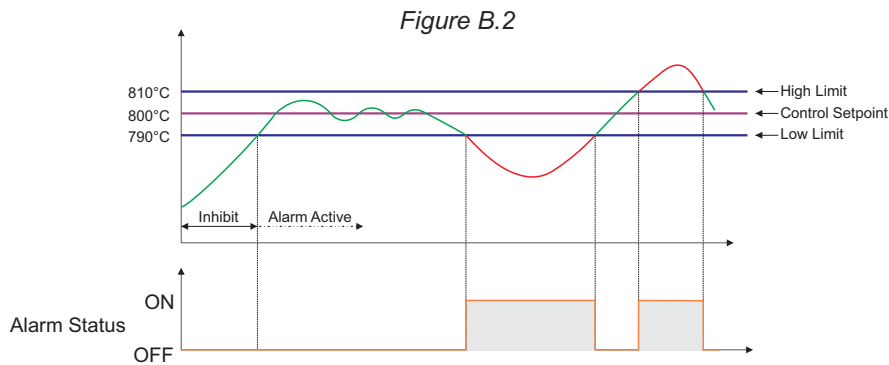

ALARM TYPES

The alarm type (together with set limit) defines the nature of deviation(s) to be notified such as process value rising above or falling below a Set Limit. There are 4 commonly used alarm types described below.

1. Process Low

In this alarm type, the process value is monitored against falling below a set limit called the Low Alarm Set-point. An alarm is generated if the process value is detected lower than the set limit.

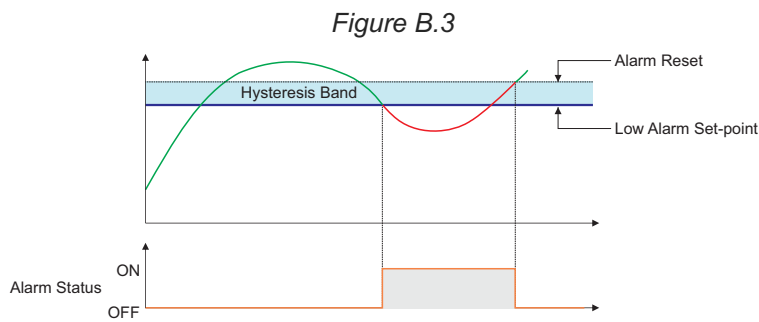

2. Process High

In this alarm type, the process value is monitored against rising above a set limit called the High Alarm Set-point. An alarm is generated if the process value is detected higher than the set limit.

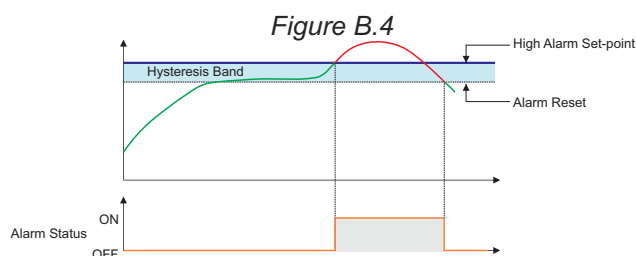

3. Deviation Band

This alarm type is implemented in the system where the process value is required to be maintained at a desired set value, called Control Set-point, with a permissible deviation in either direction - above or below. The permissible deviation is set as an offset value called Deviation Band.

A Negative offset value sets a **Low Limit** derived by subtracting the Deviation Band value from the Control Set-point. The process value is monitored against falling below the Low Limit. An alarm is generated if the process value is detected lower than this limit.

A Positive offset value sets an **High Limit** by adding the Deviation Band value to the Control Set-point. The process value is monitored against rising above the High Limit. An alarm is generated if the process value is detected higher than this limit.

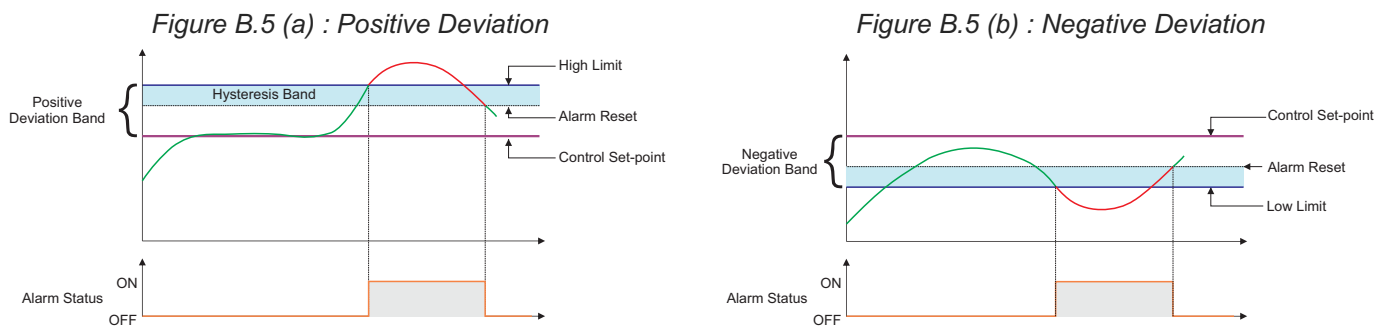

4. Window Band

This alarm type is implemented in the system where the process value is required to be maintained at a desired set value, called Control Set-point, with a symmetric permissible deviation in both directions - above and below. The symmetric permissible deviation is set as an offset value called Window Band.

The **Low Limit** is derived by subtracting the Window Band value from the Control Set-point. The process value is monitored against falling below the Low Limit. An alarm is generated if the process value is detected lower than this limit.

The **High Limit** is derived by adding the Window Band value to the Control Set-point. The process value is monitored against rising above the High Limit. An alarm is generated if the process value is detected higher than this limit.

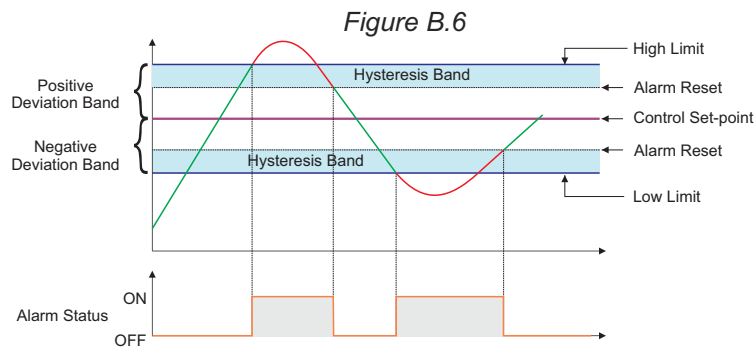



PPI
The Perfection Experts

Process Precision Instruments

101, Diamond Industrial Estate, Navghar, Vasai Road (E),
Dist. Palghar - 401 210. Maharashtra, India



Sales : 8208199048 / 8208141446

Support : 07498799226 / 08767395333



sales@ppiindia.net, support@ppiindia.net