

# HumiTherm-c Pro (Dry / Wet Version)



**PPI**  
The Perfection Experts

Enhanced  
'Temperature + Humidity'  
PID Controller  
(Dry / Wet Version)



## User Manual

## CONTENTS

1. FRONT PANEL LAYOUT	1
2. BASIC OPERATION	3
3. PAGES AND PARAMETERS	5
4. PAGE-10 : TEMPERATURE PARAMETERS	8
5. PAGE-11 : RELATIVE HUMIDITY PARAMETERS	10
6. PAGE-12 : SUPERVISORY PARAMETERS	11
7. PAGE-13 : OP3 FUNCTION PARAMETER	12
8. PAGE-33 : UTILITY PARAMETERS	13
9. PAGE-1 : COMPRESSOR OPERATION AND POWER INDIC	15
10. MECHANICAL INSTALLATION	16
11. ELECTRICAL CONNECTIONS	18

---

## Section 1 FRONT PANEL LAYOUT

The controller front panel comprises of digital readouts, LED indicators and tactile keys as shown in Figure 1.1 below.

**Figure 1.1**

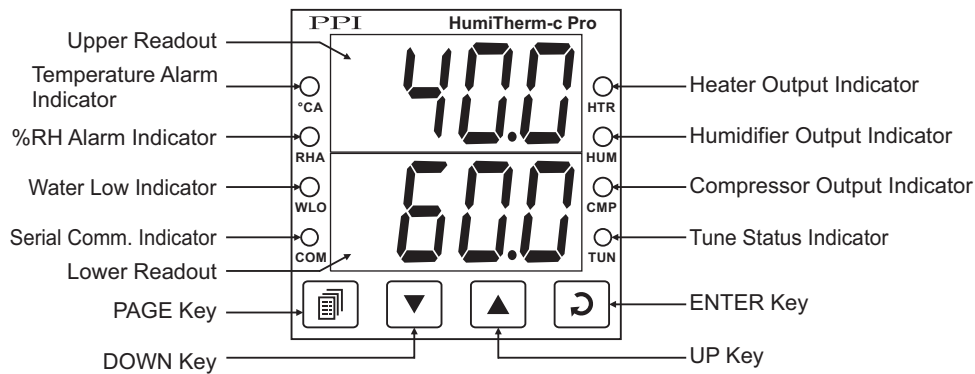

### READOUTS

The Upper Readout is a 4 digit, 7-segment bright green LED display and usually displays the Dry Bulb Temperature Value in °C. In Program Mode, the Upper Readout displays parameter values.

The Lower Readout is a 4 digit, 7-segment bright green LED display and usually displays Relative Humidity (RH) Value in %. Upon keeping the UP or DOWN key pressed, the Lower Readout displays Wet Bulb Temperature Value in °C. In Program Mode, the Lower Readout displays prompts for the parameters.

### INDICATORS

There are 8 front panel red LED indicators. These indicator show various statuses. The Table 1.1 below lists each LED indicator (identified by the front panel legend) and the associated status it indicates.





**Table 1.1**

Indicator	Function
°CA	Temperature Alarm Status. Flashes when alarm is active.
RHA	%RH Alarm Status. Flashes when alarm is active.
WLO	Water Level Status. Flashes if water level is LOW.
COM	Serial Communication Status. Flashes when data is being exchanged with Master Device.
HTR	Heater ON/OFF Status.
HUM	Humidifier ON/OFF Status.
CMP	Compressor ON/OFF Status.
TUN	Flashes while the controller is executing the Tuning operation.

## KEYS

There are four tactile keys provided on the front panel for configuring the controller and setting-up the parameter values. The Table 1.2 below lists each key (identified by the front panel symbol) and the associated function.

*Table 1.2*

Symbol	Key	Function
	PAGE	Press to enter or exit set-up mode.
	DOWN	Press to decrease the parameter value. Pressing once decreases the value by one count; keeping pressed speeds up the change.
	UP	Press to increase the parameter value. Pressing once increases the value by one count; keeping pressed speeds up the change.
	ENTER	Press to store the set parameter value and to scroll to the next parameter on the PAGE.



## Section 2 BASIC OPERATIONS

### POWER-UP

Upon switching on the power to the controller, all displays and indicators are lit on for approximately 3 seconds during which time the controller runs through a self-test sequence. This is followed by the indication of the controller model name **HUMI** on the Upper Readout and the firmware version **U.01.1** on the Lower Readout, for approximately 1 second.

### MAIN DISPLAY MODE

After the Power-up display sequence, the Upper and Lower Readouts start showing the measured Temperature Value in °C and the Relative Humidity in %RH, respectively. (The Lower Readout indication may not indicate %RH value if the controller is configured to operate in 'Temperature Only' mode.). This is called the MAIN Display Mode and this is the one that shall be used most often. The MAIN Display Mode is depicted in Figure 2.1 below.

Figure 2.1

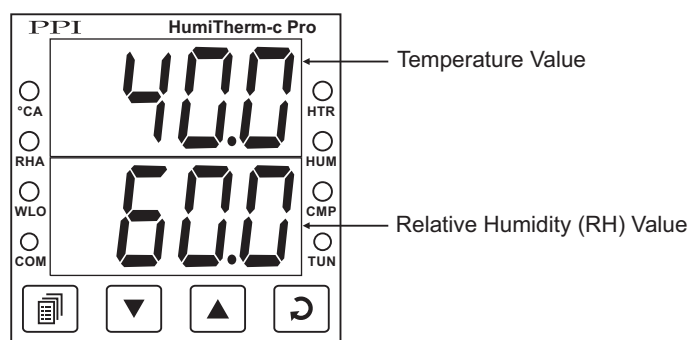

### SETPOINT ADJUSTMENTS

(Refer "Section 3 : Pages & Parameters" for details on Set-up Mode)

For ease of operation, the Temperature and Relative Humidity (% RH) Setpoints (SP) are provided on PAGE-0. The Setpoints can be adjusted, if permitted at supervisory level (PAGE-12). Step through the following sequence to adjust the SP value:

1. Press PAGE key while the controller is in MAIN Display Mode. The Lower Readout shows **PAGE** (PAGE) and the Upper Readout shows 0.
2. Press ENTER key. The Lower Readout shows the prompt for the Temperature Setpoint, **°C.SP** and the Upper Readout shows the current setpoint value.
3. Use UP/DOWN keys to adjust the Temperature SP value.
4. Press and release ENTER key. The set value for Temperature Setpoint is registered and stored in the controller's non-volatile memory. The Lower Readout shows the prompt for the %RH Setpoint, **rh.SP** and the Upper Readout shows the current setpoint value.
5. Use UP/DOWN keys to adjust the %RH SP value.
6. Press and release ENTER key. The set value for RH Setpoint is registered and stored in the controller's non-volatile memory.
7. Press PAGE key to revert to MAIN Display Mode.

### TEMPERATURE-ONLY MODE

The controller can be configured to operate in Temperature-only mode by setting the %RH SP value to 0. In this mode, the controller controls only the Dry Bulb Temperature at the set value through Heater Control Output-1. The %RH Control Output-2 is kept off. The Lower Readout in this case can be selected to either display the %RH value (If Wet Bulb RTD sensor is connected) or the Temperature Unit °C. The parameter **Lower** (Lower Readout Indication) can be set to **rh** (% R H indication) or **Unit** (°C Indication). This selection is available only if %RH SP value is set to 0.

### TUNE INDICATION

Upon issuing TUNE command, the controller starts tuning itself to the process under control. While the controller is executing Tuning operation, the front panel indicator TUN flashes. The user is advised not to disturb the process or alter any parameter values while the tuning is in progress. The TUN indicator automatically turns OFF upon completion of Tuning Procedure. The controller reverts to the MAIN Display Mode and starts maintaining the Temperature and RH values (PV) at their respective Setpoints.

### PV ERROR INDICATIONS

The controller indicates the PV error messages for both Temperature and RH Values on Upper and Lower Readout, respectively, in the following conditions.

#### Error Indication for Dry Bulb Temperature (Upper Readout)

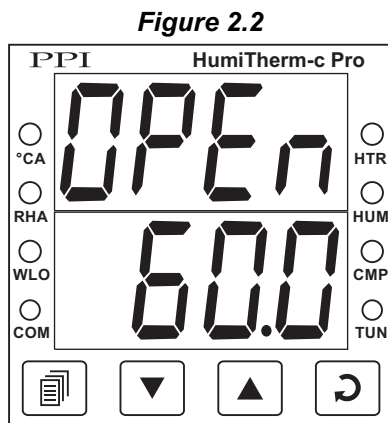

Table 2.1

Message	PV Error Type
<b>Dr</b>	Over-range (Dry-Bulb Temp. above Max. Range)
<b>Ur</b>	Under-range (Dry-Bulb Temp. below Min. Range)
<b>OPEN</b>	Open (Sensor open / broken)

#### Error Indication for Relative Humidity (RH) (Lower Readout)

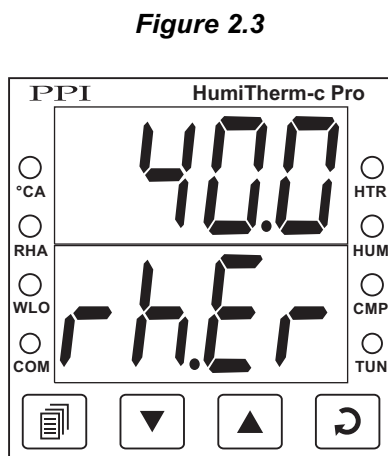

Table 2.2

Message	PV Error Type
<b>Dr</b>	Over-range (Wet-Bulb Temp. above Max. Range)
<b>Ur</b>	Under-range (Wet-Bulb Temp. below Min. Range)
<b>OPEN</b>	Open (Sensor open / broken)
<b>rh.Er</b>	Either Dry Bulb Temp. is below -20.0°C or above 162.0°C. The error may also occur if Wet Bulb depression is more than 60.0°C.

## Section 3 PAGES AND PARAMETERS

### ORGANIZATION

The controller requires various user settings that determine how the controller will function or operate. These settings are called Parameters.

The parameters are always presented in a fixed format: The Lower Readout displays the parameter prompt (Identification Tag) and the Upper Readout displays the set value. The parameters appear in the same sequence as listed in their respective sections.

For convenience and ease of memorizing, the various parameters have been arranged in different groups depending upon the functions the parameters represent. Each group is assigned a unique PAGE NUMBER for its access and the parameters within each group are presented for settings depending upon the function(s) selected.

### PROGRAM MODE

The Program Mode allows the user to view or modify the parameter values. The entry from MAIN Display Mode to Program Mode requires appropriate setting of the PAGE NUMBER. Follow the steps below to open a desired PAGE for setting the parameter values:

*Figure 3.1*

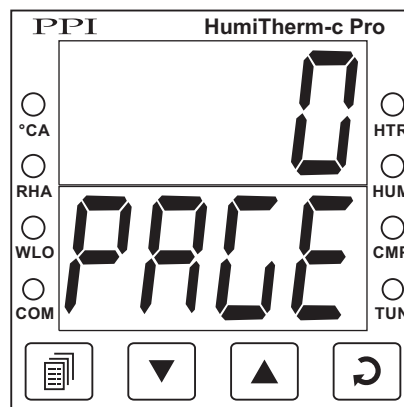

1. Press and release PAGE key. The Lower Readout shows PAGE and the Upper Readout shows 0. See Figure 3.1.
2. Adjust the Upper Readout to the desired PAGE NUMBER using the UP/DOWN keys.
3. Press and release ENTER key. The Lower Readout shows the prompt for the first parameter listed in the PAGE and the Upper Readout shows its current value.

#### Note

If the entered PAGE NUMBER is invalid (contains no parameter list or any associated function), the controller reverts to the MAIN Display Mode.

### Adjusting Parameter Values

Once a PAGE is accessed, step through the following sequence to adjust the values of the desired parameters:

1. Press and release the ENTER key until the prompt for the desired parameter appears on the Lower Readout. The last parameter in the list rolls back to the first parameter.
2. Use UP / DOWN keys to adjust the parameter value.

Note that some parameters (examples; 'Alarm Band', 'Proportional Band', 'Zero Offset for PV' etc.) have numeric values

while others (examples; 'Baud Rate', 'Compressor Control Strategy', etc.) have a series of options. If adjusting a numeric value; depressing the UP/DOWN key once, increases/decreases the parameter value by one digit. For parameters having a series of options, depressing the UP/DOWN key once takes you to the next/previous option. In each case, keeping the UP/DOWN key pressed speeds up the rate. If the value reaches the maximum / minimum settable value/option, the Upper Readout flashes and the UP (if maximum value is reached) or DOWN (if minimum value is reached) key has no effect.

3. Press and release the ENTER key. The new value gets stored in the controller's non-volatile memory and the next parameter in the list is displayed.

The Figure 3.2 illustrates the example of altering the value for the parameter '%RH Alarm Band' value from 2.0%RH to 2.5%RH.

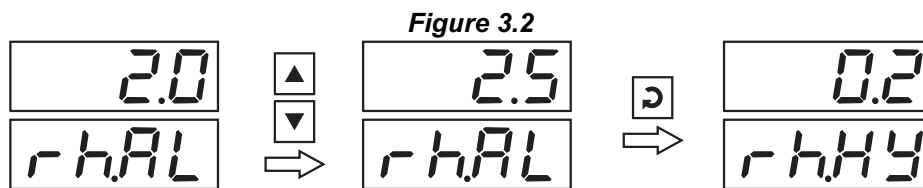

To exit the Program Mode and return to the MAIN Display Mode, press and release PAGE key.

**Note**

If the controller is left in Program Mode for more than 30 seconds without any key operation, the controller automatically exits the Program Mode and returns to the MAIN Display Mode.

**PARAMETER LOCKING**

Though access to any PAGE is always permitted, the adjustment of the parameter values, however, can be Locked at the supervisory level. If the Lock is enabled, the parameter values on each PAGE can only be viewed but can not be adjusted. This feature facilitates protecting the parameter values from unauthorized tampering or accidental alterations by the operator.

The controller is shipped from the factory in Unlocked condition. The Lock can be enabled once the initial configuration / installation is done.

For enabling / disabling the Lock, step through the following sequence:

**Locking**

1. Press and release PAGE key while the controller is in the MAIN Display Mode. The Lower Readout shows PAGE and the Upper Readout shows 0.
2. Adjust the Upper Readout to the value 123 using UP/DOWN keys.
3. Press and release ENTER key. The controller returns to the MAIN Display Mode with the Lock enabled.

The Figure 3.3 below illustrates the Locking procedure.

**Figure 3.3**

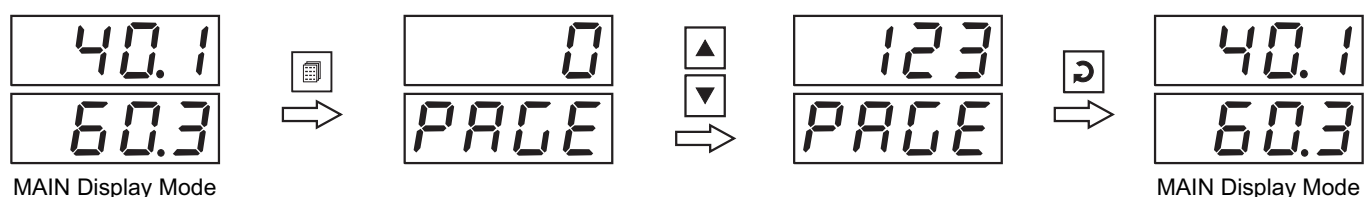



**Unlocking**

1. Press and release PAGE key while the controller is in the MAIN Display Mode. The Lower Readout shows PAGE and the Upper Readout shows 0.
2. Adjust the Upper Readout to the value 123 using UP/DOWN keys.
3. Press and release ENTER key. The controller returns to the MAIN Display Mode.
4. Repeat steps 1 through 3. This time the controller returns to the MAIN Display Mode with the Lock disabled (Unlocked).

**SETTING DEFAULT VALUES**







The controller is shipped from the factory with all the parameters set to their default factory set values. If desired, all the parameters can be reset to default values by following the steps below.

1. Ensure that the controller is Unlocked for parameter adjustments.
2. Press and release PAGE key while the controller is in the MAIN Display Mode. The Lower Readout shows PAGE and the Upper Readout shows 0.
3. Adjust the Upper Readout to the numeric value 99 using UP/DOWN keys.
4. Press and release ENTER key. The controller resets and restarts from Power-up display sequence with all the parameters set to their factory set default values.



Section 4  
PAGE-10 : TEMPERATURE PARAMETERS

Table 4.1

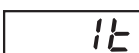
Parameter Description	Settings (Default Value)
<p><b>ALARM-1 BAND</b> <span style="float: right;"></span></p> <p>Sets symmetrical positive and negative deviation (offset) limits from Temperature control setpoint for both High and Low Alarm-1 activation. Example: If Band = 0.5°C, then High Alarm Limit = Setpoint + 0.5°C Low Alarm Limit = Setpoint - 0.5°C</p>	<p>0.3 to 25.0°C (Default : 0.5)</p>
<p><b>ALARM-1 HYSTERESIS</b> <span style="float: right;"></span></p> <p>Sets differential (dead) band between ON and OFF states of Alarm-1.</p>	<p>0.2 to 10.0°C (Default : 0.2)</p>
<p><b>PROPORTIONAL BAND</b> <span style="float: right;"></span></p> <p><b>(Available for T + RH mode)</b></p> <p>Sets proportional gain (% power per unit error) for temperature control loop. Defined in same units and resolution as that for PV.</p>	<p>0.1 to 999.9°C (Default : 5.0)</p>
<p><b>INTEGRAL TIME</b> <span style="float: right;"></span></p> <p><b>(Available for T + RH mode)</b></p> <p>Sets integral time constant in seconds for temperature control loop. Setting the value to 0, cuts-off the integral action.</p>	<p>0 to 1000 Seconds (Default : 100)</p>
<p><b>DERIVATIVE TIME</b> <span style="float: right;"></span></p> <p><b>(Available for T + RH mode)</b></p> <p>Sets derivative time constant in seconds for temperature control loop. Setting the value to 0, cuts-off the derivative action.</p>	<p>0 to 250 Seconds (Default : 25)</p>
<p><b>PROPORTIONAL BAND</b> <span style="float: right;"></span></p> <p><b>(Available for Temperature-only mode)</b></p> <p>Sets proportional gain (% power per unit error) for temperature control loop. Defined in same units and resolution as that for PV.</p>	<p>0.1 to 999.9°C (Default : 5.0)</p>
<p><b>INTEGRAL TIME</b> <span style="float: right;"></span></p> <p><b>(Available for Temperature-only mode)</b></p> <p>Sets integral time constant in seconds for temperature control loop. Setting the value to 0, cuts-off the integral action.</p>	<p>0 to 1000 Seconds (Default : 100)</p>

Parameter Description	Settings (Default Value)
<p><b>DERIVATIVE TIME</b> <span style="float: right; border: 1px solid black; padding: 2px;">dt</span></p> <p><b>(Available for Temperature-only mode)</b></p> <p>Sets derivative time constant in seconds for temperature control loop. Setting the value to 0, cuts-off the derivative action.</p>	<p>0 to 250 Seconds (Default : 25)</p>
<p><b>CYCLE TIME</b> <span style="float: right; border: 1px solid black; padding: 2px;">dbct</span></p> <p>Sets the total 'On + Off' time in seconds for time proportional power output for temperature control loop through Output-1.</p>	<p>0.5 to 25.0 Seconds (in steps of 0.5 secs.) (Default : 1.0)</p>









Section 5  
**PAGE-11 : RELATIVE HUMIDITY (%RH) PARAMETERS**

The **PAGE-11** lists Alarm and Control related parameters for %RH. The Table 5.1 below describes each parameter.

**Note : This page is not available if the controller is configured to operate in Temperature-only Mode.**

*Table 5.1*

Parameter Description	Settings (Default Value)
<p><b>%RH ALARM BAND</b> <span style="float: right;"></span></p> <p>Sets symmetrical positive and negative deviation (offset) limits around %RH control setpoint for High and Low alarm activations, respectively.                      Example:                      If Band = 2.0 % RH, then                      High Alarm Limit = Setpoint + 2.0 % RH                      Low Alarm Limit = Setpoint - 2.0 % RH</p>	<p>0.3 to 25.0%RH                      (Default : 2.0%RH)</p>
<p><b>%RH ALARM HYSTERESIS</b> <span style="float: right;"></span></p> <p>Sets differential (dead) band between ON and OFF states of Alarm.</p>	<p>0.2 to 10.0%RH                      (Default : 0.2%RH)</p>
<p><b>%RH PROPORTIONAL BAND</b> <span style="float: right;"></span></p> <p>Sets proportional gain (% power per unit error) for %RH control loop.</p>	<p>0.1 to 999.9%RH                      (Default : 10.0%RH)</p>
<p><b>%RH INTEGRAL TIME</b> <span style="float: right;"></span></p> <p>Sets integral time constant in seconds for %RH control loop. Setting the value to 0, cuts-off the integral action.</p>	<p>0 to 1000 Seconds                      (Default : 100)</p>
<p><b>%RH DERIVATIVE TIME</b> <span style="float: right;"></span></p> <p>Sets derivative time constant in seconds for %RH control loop. Setting the value to 0, cuts-off the derivative action.</p>	<p>0 to 250 Seconds                      (Default : 25)</p>
<p><b>%RH CYCLE TIME</b> <span style="float: right;"></span></p> <p>Sets the total 'On + Off' time in seconds for time proportional power output for %RH control loop.</p>	<p>0.5 to 25.0 Seconds                      (in steps of 0.5 secs.)                      (Default : 1.0)</p>

Section 6  
**PAGE-12 : SUPERVISORY PARAMETERS**

The Supervisory Parameters provided on **PAGE-12** facilitate supervisory control over the operator level. The Table 6.1 below describes each parameter.

**Table 6.1**

Parameter Description	Settings (Default Value)
<p><b>SETPOINT ADJUSTMENT ON PAGE-0</b> <span style="float: right;">SP</span></p> <p>Supervisory permission for temperature and %RH setpoint editing on Operator Page (PAGE-0). Set to 'Enable' for permission.</p>	<p><span style="border: 1px solid black; padding: 2px;">d5bL</span> Disable  <span style="border: 1px solid black; padding: 2px;">EnbL</span> Enable                      (Default : Enable)</p>
<p><b>SELF-TUNE COMMAND</b> <span style="float: right;">tUnE</span></p> <p>Set to 'Yes' to initiate a new tuning cycle or set to 'No' to abort a tuning operation in progress.</p>	<p><span style="border: 1px solid black; padding: 2px;">no</span> No  <span style="border: 1px solid black; padding: 2px;">YES</span> Yes                      (Default : No)</p>
<p><b>WATER LEVEL-LOW DETECTION LOGIC</b> <span style="float: right;">YLLO</span></p> <p>Set to 'Open' or 'Close' depending upon whether <i>contact-open</i> or <i>contact-close</i> means <i>water low</i> detection.</p>	<p><span style="border: 1px solid black; padding: 2px;">OPeN</span> Open  <span style="border: 1px solid black; padding: 2px;">CLoS</span> Close                      (Default : Open)</p>
<p><b>SLAVE ID</b> <span style="float: right;">1d</span></p> <p>Communication ID used by host for serial communication.</p>	<p>1 to 127                      (Default : 1)</p>
<p><b>BAUD RATE</b> <span style="float: right;">bAUd</span></p> <p>Communication speed in 'Bits per Second'. Set the value to match with the host baud rate.</p>	<p><span style="border: 1px solid black; padding: 2px;">4.8</span> 4800  <span style="border: 1px solid black; padding: 2px;">9.6</span> 9600  <span style="border: 1px solid black; padding: 2px;">19.2</span> 19200                      (Default : 9600)</p>
<p><b>PARITY</b> <span style="float: right;">PARi</span></p> <p>Parity setting for serial communication protocol</p>	<p><span style="border: 1px solid black; padding: 2px;">nonE</span> None  <span style="border: 1px solid black; padding: 2px;">EvEn</span> Even  <span style="border: 1px solid black; padding: 2px;">Odd</span> Odd                      (Default : Even)</p>
<p><b>COMMUNICATION WRITE ENABLE</b> <span style="float: right;">CoñE</span></p> <p>Setting to 'No' disallows the host to set or modify any parameter values. The parameter values however, are still available for reading by the host.</p>	<p><span style="border: 1px solid black; padding: 2px;">no</span> No  <span style="border: 1px solid black; padding: 2px;">YES</span> Yes                      (Default : Yes)</p>

Section 7  
**PAGE-13 : COMPRESSOR PARAMETERS**

The Compressor Parameters presented on **PAGE-13** allow the user to configure the Output type & other control related parameters. The Table 7.1 below describes each parameter.

**Table 7.1**

Parameter Description	Settings (Default Value)
<p><b>COMPRESSOR SETPOINT</b> <span style="float: right;"><b>[C.P.S.P]</b></span></p> <p>The setpoint value with which either the Temperature SP or PV is compared for the purpose of switching the compressor On / Off. Refer <i>section-8</i> for details.</p>	<p>0.0 to 50.0°C <b>or</b>                      0.0 to 25.0°C                      (Default : 45.0 <b>or</b> 0.2)</p>
<p><b>COMPRESSOR HYSTERESIS</b> <span style="float: right;"><b>[C.P.H.Y]</b></span></p> <p>Sets differential (dead) band between Compressor switching ON and OFF states. Refer <i>section-8</i> for details.</p>	<p>0.1 to 25.0°C                      (Default : 0.2)</p>
<p><b>COMPRESSOR TIME DELAY</b> <span style="float: right;"><b>[C.T.D.L.Y]</b></span></p> <p>The Time Delay that must elapse before the compressor is switched ON from OFF state. Setting to 0 cuts-off the time delay function.</p>	<p>0.00 to 10.00 Min. Sec                      (in steps of 5 Seconds)                      (Default : 00.00)</p>



Section 8  
**PAGE-33 : UTILITY PARAMETERS**

The Utility Parameters are grouped on **PAGE-33** and allow the user to set the Compressor Control Strategy and the Zero-Offset values for Temperature and the Relative Humidity (RH) values. The Table 8.1 below describes each parameter.

*Table 8.1*

Parameter Description	Settings (Default Value)
<p><b>COMPRESSOR CONTROL STRATEGY</b> <span style="float: right;"><b>CP.SP</b></span></p> <p>Refer detailed description below.</p>	<p><b>db.SP</b> Dry Bulb SP</p> <p><b>db.PV</b> Dry Bulb PV (Default : Dry Bulb SP)</p>
<p><b>ZERO OFFSET FOR DRY-BULB TEMPERATURE VALUE</b> <span style="float: right;"><b>db.oF</b></span></p> <p>This value is algebraically added to the measured Dry-Bulb Temperature value to derive the final PV that is displayed and compared for alarm / control.</p>	<p>-25.0 to +25.0°C (Default : 0.0)</p>
<p><b>ZERO OFFSET FOR WET BULB TEMPERATURE VALUE</b> <span style="float: right;"><b>wb.oF</b></span></p> <p>This value is algebraically added to the measured Wet-Bulb Temperature value to derive the final PV that is used to compute the % RH Value.</p>	<p>-25.0 to +25.0°C (Default : 0.0)</p>
<p><b>ZERO OFFSET FOR RH VALUE</b> <span style="float: right;"><b>rh.oF</b></span></p> <p>This value is algebraically added to the measured %RH value to derive the final PV that is displayed and compared for alarm / control.</p>	<p>-25.0 to +25.0% (Default : 0.0)</p>

**COMPRESSOR CONTROL STRATEGY**

The controller offers two different control algorithms for switching the compressor through Output 3 (OP3) Relay / SSR module using the parameter 'Compressor Control Strategy'. The two strategies are explained below. Note that either strategy operates (switches ON/OFF) the OP3 only if the parameter 'OP3 Function' on PAGE-13 is set to 'Compressor' and the 'Compressor Operation Mode ( CP.OP )' parameter on PAGE-1 is set to 'Auto'.

**1. Dry Bulb SP Strategy**

In this strategy, the controller provides two user settable parameters, viz. *Compressor Set-point* (CP.SP) & *Time Delay* (t.dLY) in PAGE 13 parameter list.

The Compressor ON or OFF state is determined based on the relative position of the Dry Bulb SP (Temperature Set-point) with respect to the *Compressor Set-point*. If the Dry Bulb SP is below the Compressor Set-point, the compressor remains ON and if the Dry Bulb SP is equal or above the Compressor Set-point, the compressor remains OFF. The following Figures 8.1 and 8.2 illustrate the compressor ON and compressor OFF operation respectively.

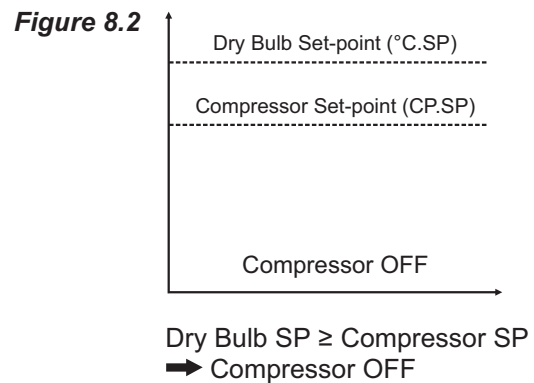
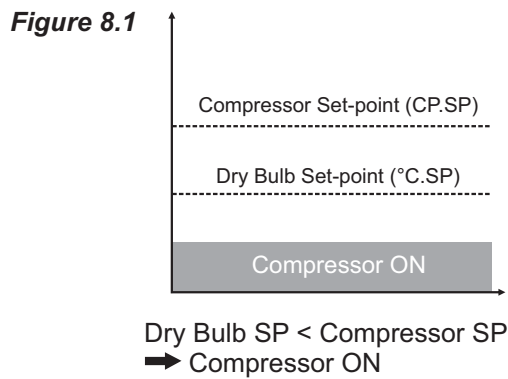

This strategy eliminates the dependency on the user for switching off the compressor (for saving valuable electrical energy) when not required. The Compressor Set-point for this parameter value is usually set to the maximum expected Ambient Temperature. It is usually not required to switch-on compressor if the desired Temperature is significantly above the Ambient Temperature and thus a considerable energy saving can be achieved by keeping the compressor OFF.

### 2. Dry Bulb PV Strategy

In this strategy, the controller provides three user settable parameters, viz. Compressor Set-point (CP.SP), Hysteresis (CP.HY) & Time Delay (t.dLY) in PAGE 13 parameter list. The Compressor ON or OFF state is determined by comparing the Dry Bulb PV with the Compressor Switch-on Level and the Compressor Switch-off Level. The Compressor Switch-on and Switch-off levels are determined using Dry Bulb SP (db.SP), Compressor Set-point (CP.SP) and Hysteresis (CP.HY), as below.

$$\begin{aligned} \text{Switch-on Level} &= \text{Dry Bulb SP (db.SP)} + \text{Compressor SP (CP.SP)} \\ \text{Switch-off Level} &= \text{Switch-on Level} - \text{Hysteresis (CP.HY)} \end{aligned}$$

The Hysteresis introduces a dead-band between the Compressor Switch-on Level and Switch-off Level. The following Figure 8.3 illustrates the compressor ON-OFF operation.

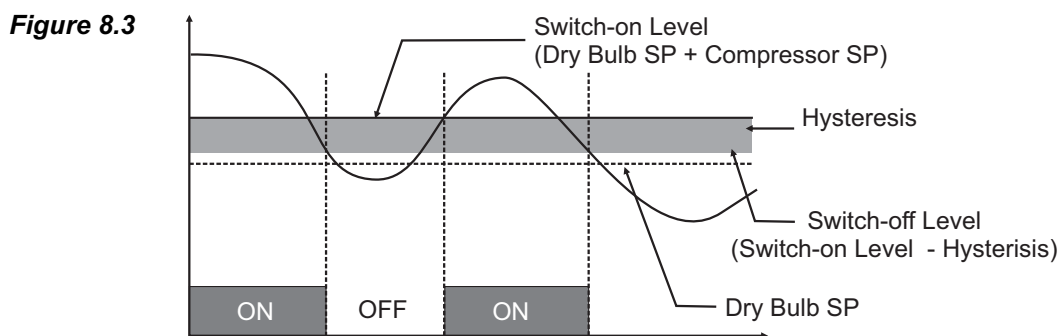

#### Examples

- 1) For Dry Bulb SP = 20.0°C, Compressor SP = 1.0°C & Hysteresis = 1.2°C;  
 Switch-on Level = Dry Bulb SP + Compressor SP = 20.0 + 1.0 = 21.0°C  
 Switch-off Level = Switch-on Level - Hysteresis = 21.0 - 1.2 = 19.8°C.
- 2) For Dry Bulb SP = 20.0°C, Compressor SP = 1.0°C & Hysteresis = 0.8°C;  
 Switch-on Level = Dry Bulb SP + Compressor SP = 20.0 + 1.0 = 21.0°C  
 Switch-off Level = Switch-on Level - Hysteresis = 21.0 - 0.8 = 20.2°C.



Section 9

**PAGE-1 : COMPRESSOR OPERATION & POWER INDICATION**

The **PAGE-1** allows the operator to select the compressor switching as 'Automatic' or 'Manual', through a parameter 'Compressor Operation'. This parameter is available and applicable only if the 'Compressor Control' is selected for 'Output-3 (OP3) Function' in PAGE-13 parameter list. The page also facilitates viewing the PID output powers for both Temperature and %RH control loops and also Wet-Bulb Setpoint. Refer Table 9.1 below.

Table 9.1

Parameter Description	Settings (Default Value)
<p><b>COMPRESSOR OPERATION MODE</b> <span style="border: 1px solid black; padding: 2px;">CP.OP</span></p> <p>If selected as 'Auto', the compressor switching is determined by the controller based on the setting for the parameter 'Compressor Control Strategy' on PAGE-33.</p> <p>The 'Off' or 'On' selection allows the operator to manually switch the compressor OFF or ON regardless of the 'Compressor Control Strategy'.</p>	<div style="display: flex; flex-direction: column; align-items: center;"> <div style="display: flex; align-items: center; margin-bottom: 5px;"> <div style="border: 1px solid black; padding: 2px; margin-right: 5px;">On</div> <div>On</div> </div> <div style="display: flex; align-items: center; margin-bottom: 5px;"> <div style="border: 1px solid black; padding: 2px; margin-right: 5px;">OFF</div> <div>Off</div> </div> <div style="display: flex; align-items: center; margin-bottom: 5px;"> <div style="border: 1px solid black; padding: 2px; margin-right: 5px;">AUTO</div> <div>Automatic</div> </div> <p>(Default : Auto)</p> </div>
<p><b>WET-BULB TEMPERATURE SETPOINT</b> <span style="border: 1px solid black; padding: 2px;">46.5P</span></p> <p>This value is derived using Dry-Bulb SP &amp; %RH SP.</p>	<p>Within Specified Temperature Range (View Only - Non editable)</p>
<p><b>OUTPUT POWER FOR TEMPERATURE LOOP</b> <span style="border: 1px solid black; padding: 2px;">OUT.1</span></p>	<p>0 to 100.0% (View Only - Non editable)</p>
<p><b>OUTPUT POWER FOR %RH LOOP</b> <span style="border: 1px solid black; padding: 2px;">OUT.2</span></p>	<p>0 to 100.0% (View Only - Non editable)</p>



## Section 10 MECHANICAL INSTALLATION

### OUTER DIMENSIONS AND PANEL CUTOUT

The Figure 10.1 shows the controller outer dimensions.

**Figure 10.1**

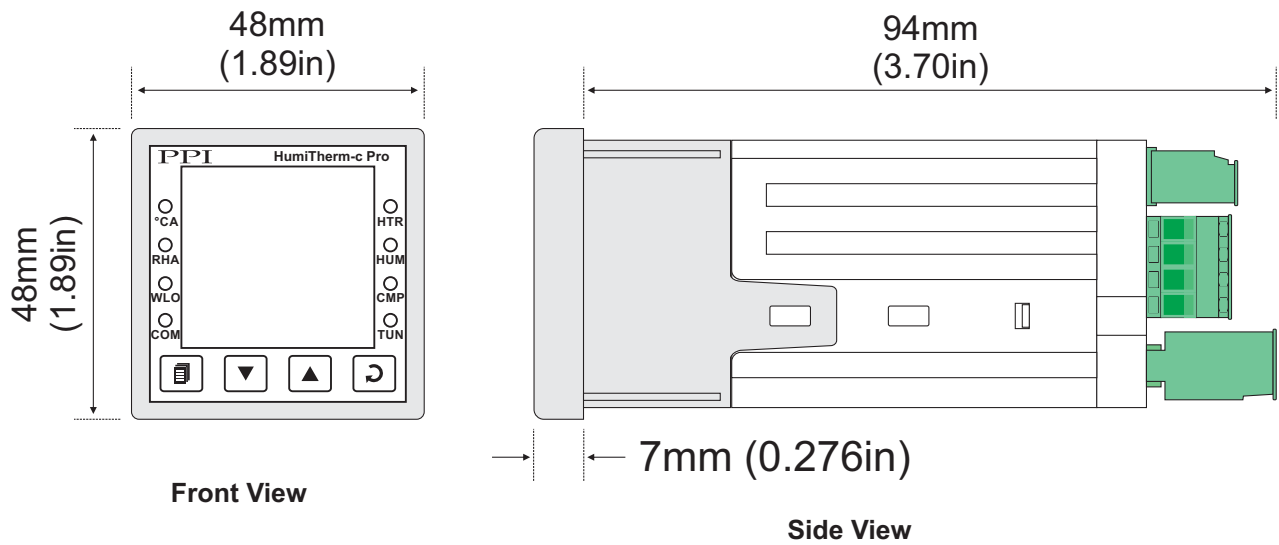

### PANEL CUTOUT

The Figure 10.2 shows the panel cutout requirements for a single controller.

**Figure 10.2**

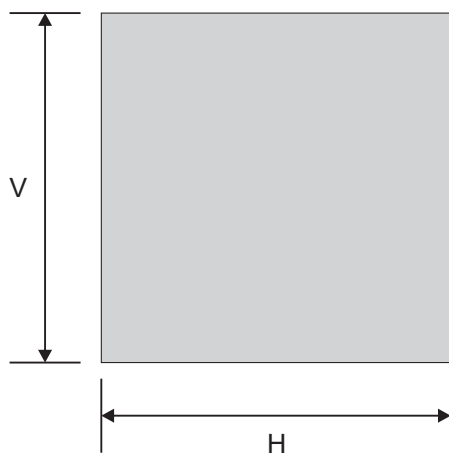

Parameter	Dimensions	
	mm	inches
H	45 (-0, +0.5)	1.77 (-0, +0.02)
V	45 (-0, +0.5)	1.77 (-0, +0.02)

## PANEL MOUNTING

Follow the steps below for mounting the controller on panel:

1. Prepare a square cutout to the size shown in Figure 10.2.
2. Remove the Panel Mounting Clamp from the controller Enclosure and insert the rear of the controller housing through the panel cutout from the front of the mounting panel.
3. Hold the controller gently against the mounting panel such that it positions squarely against the panel wall, see Figure 10.3. Apply pressure only on the bezel and not on the front label.
4. Insert the mounting clamps on either side of the controller in the slots provided for the purpose. Rotate the screws clockwise so that they move forward until they push firmly against the rear face of the mounting panel for secured mounting.

**Figure 10.3**

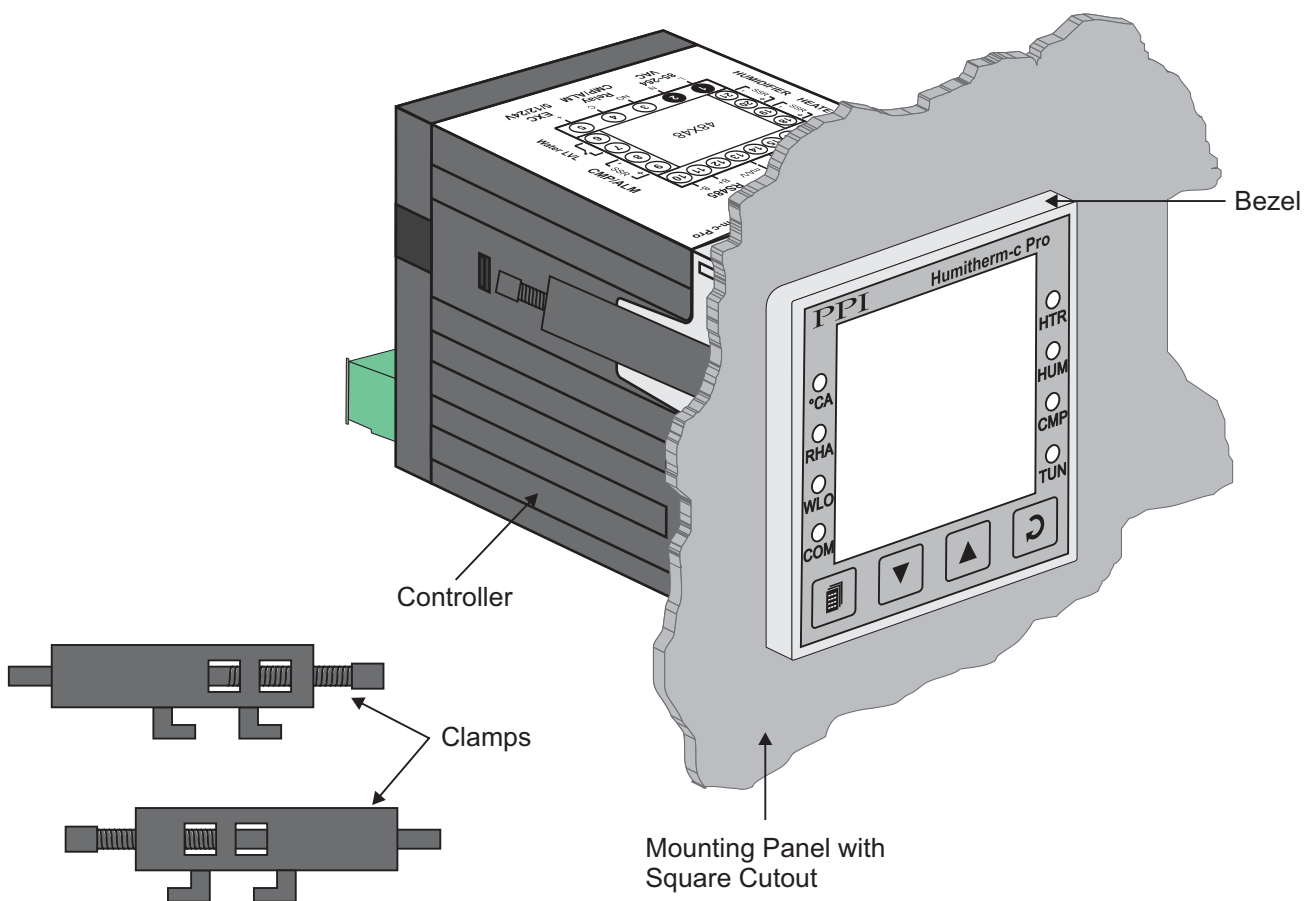

## Section 11 ELECTRICAL CONNECTIONS

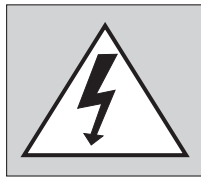

**WARNING**  
**MISHANDLING / NEGLIGENCE CAN**  
**RESULT IN PERSONAL DEATH OR**  
**SERIOUS INJURY.**

1. The user must rigidly observe the Local Electrical Regulations.
2. Do not make any connections to the unused terminals for making a tie-point for other wires (or for any other reasons) as they may have some internal connections. Failing to observe this may result in permanent damage to the controller.
3. Run power supply cables separated from the low-level signal cables (like RTD, DC Linear (Voltage) signals, etc.). If the cables are run through conduits, use separate conduits for power supply cable and low-level signal cables.
4. Use appropriate fuses and switches, wherever necessary, for driving the high voltage loads to protect the controller from any possible damage due to high voltage surges of extended duration or short-circuits on loads.
5. Take care not to over-tighten the terminal screws while making connections.
6. Make sure that the controller supply is switched-off while making/removing any connections or removing the controller from its enclosure.

### CONNECTION DIAGRAM

The Electrical Connection Diagram is shown on the top side of the enclosure. The diagram shows the terminals viewed from the REAR SIDE with the controller label upright. The connectors provided for wiring are pluggable male-female type. The female parts are soldered on the controller PCBs while the male parts are with screws and removable. The rear panel electrical wiring connection diagram is shown in Figure 11.1.

**Figure 11.1**

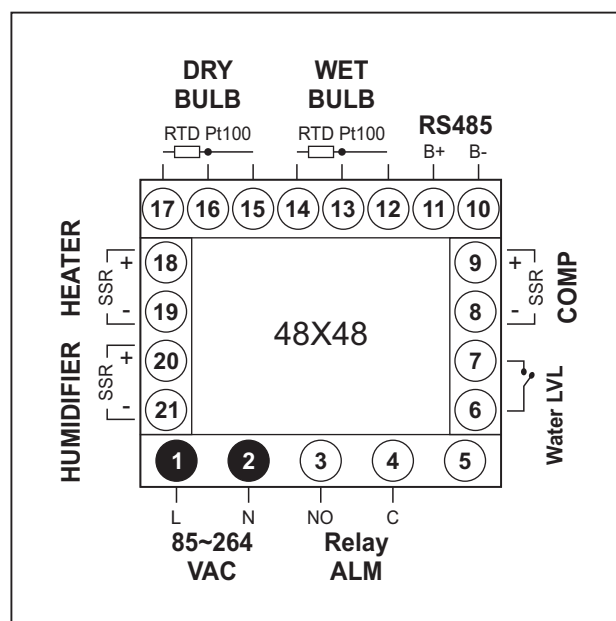

**DESCRIPTIONS**

**DRY BULB INPUT** : RTD Pt100 (Terminals 17, 16, 15)

**WET BULB INPUT** : RTD Pt100 (Terminals 14, 13, 12)

RTD Pt100, 3-wire

Connect single lead end of RTD bulb to terminal 17 (14) and the double lead ends to terminal 16 (13) and 15 (14), interchangeable, as shown in Figure 11.2. Use copper conductor leads of very low resistance ensuring that all 3 leads are of the same gauge and length. Avoid joints in the cable.

**Figure 11.2 (a)**

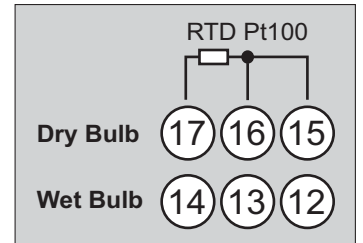

**HEATER** : DC Voltage Pulses for SSR Drive for Heater Control (Terminals 18, 19)

**HUMIDIFIER** : DC Voltage Pulses for SSR Drive for Humidification Control (Terminals 20, 21)

**COMP** : DC Voltage Pulses for SSR Drive for Compressor Control (Terminals 8, 9)

12 VDC pulses are generated for switching the external SSR (Solid State Relay). Connect (+) and (-) terminals of SSR to controller terminals 18 / 20 / 9 and 19 / 21 / 8, respectively. Use Zero-Crossover, 3 to 30 VDC operated SSR, rated approximately 1.5 times the actual load rating. Use appropriate Heat Sink for load rating exceeding 10A.

**Figure 11.4**

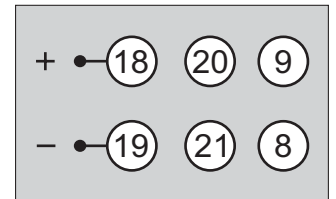

**Relay ALM** : Potential-free Relay Contacts for Alarm Control (Terminals 3, 4)

Potential-free Relay changeover contacts N/O (Normally Open) and C (Common) rated 2A/240 VAC (resistive load) are provided as Relay output. Use external auxiliary device like contactor with appropriate contact rating for driving the actual load.

**Figure 11.5**

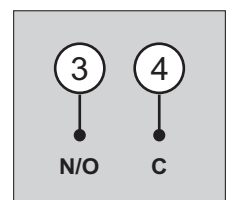

**Water LVL** : Low Water-Level Detection Digital Input (Terminals : 6, 7)

Potential-free contact closure input terminals are provided as digital inputs for low water level detection. An user programmable 'Open' or 'Close' switch position is detected as water level low.

**Figure 11.6**

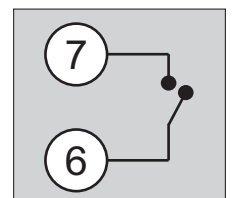

**RS485 : Serial Communication Port (Terminals 10, 11)**

Connect terminal 11 and 10 of the controller to (+) and (-) RS485 terminals of the Master device.

To ensure reliable operation of the Serial Communication Link (without data corruption due to line noise or reflections), use a pair of twisted wires inside screened cable with the terminating resistor (100 to 150 Ohms) at one end, as shown in Figure 11.7 below.

**Figure 11.7**

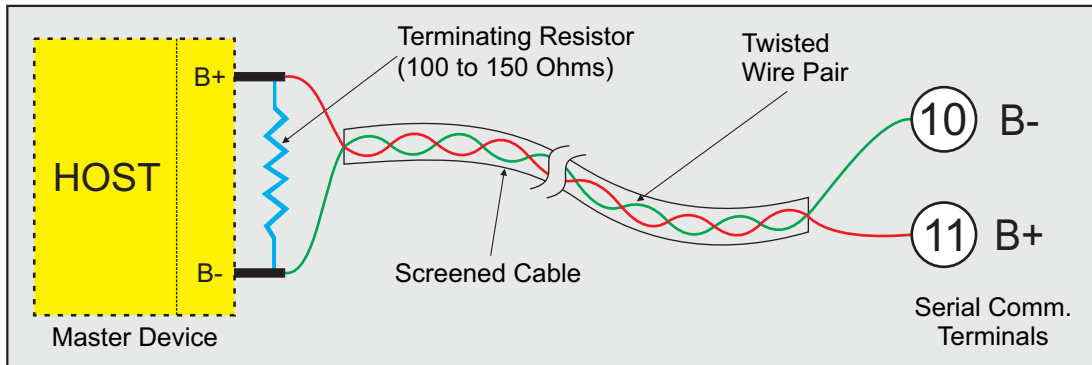

**85~264 VAC : Power Supply (Terminals 1, 2)**

The controller is supplied with power connections suited for 85 to 264 VAC line supply. Use well-insulated copper conductor wire of the size not smaller than 0.5mm<sup>2</sup> for power supply connections. Connect Line (Phase) supply line to terminal 1 and the Neutral (Return) supply line to terminal 2 as shown in Figure 11.8 below. The controller is not provided with fuse and power switch. If necessary, mount them separately. Use a time lag fuse rated 1A @ 240 VAC.

**Figure 11.8**

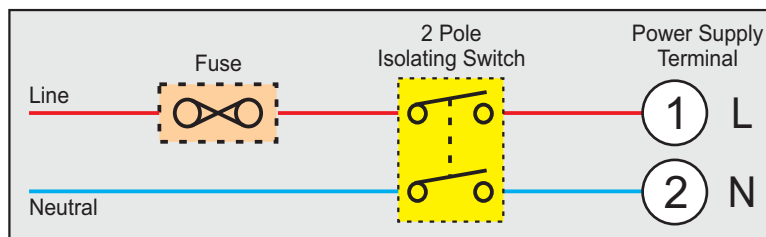



**PPI**  
The Perfection Experts

## Process Precision Instruments

101, Diamond Industrial Estate, Navghar, Vasai Road (E),  
Dist. Palghar - 401 210. Maharashtra, India



Sales : 8208199048 / 8208141446

Support : 07498799226 / 08767395333



[sales@ppiindia.net](mailto:sales@ppiindia.net), [support@ppiindia.net](mailto:support@ppiindia.net)