

### Features

- Universal Input (Thermocouples, RTD Pt100, DC Linear mA/mV/V)
- Programmable Range / Resolution for DC Linear Inputs
- Programmable Input Signal Conditioning (Digital Filter & Zero Offset)
- Self Tune PID, On-Off, Pulsed Control Mode
- Optional Bi-Directional Control
- Relay / SSR or DC Linear Voltage / Current Control Output
- 4 / 8 / 12 / 16 Segment Ramp/Soak Profile
- Optional Auxiliary Control Set Point with Remote Switching Input
- Optional Programmable Alarms / Retransmission Outputs
- Optional Serial Communication Port
- DIN Standard Dimensions : 48(H) X 48(W) X 110(D), mm  
96(H) X 96(W) X 65(D), mm



### Specifications

Display	
Digital Readout 48 x 48	Upper Readout : 4 digits, 0.39" Bright Red LED, 7 Segment Lower Readout : 4 digits, 0.3" Luminous Green LED, 7 Segment
Digital Readout 96 X 96	Upper Readout : 4 digits, 0.56" Bright Red LED, 7 Segment Lower Readout : 4 digits, 0.56" Luminous Green LED, 7 Segment
Status Indicators	5 Red LEDs (3mm Round)
Keys	
Type	4 Tactile Switches
Functions	PAGE, DOWN, UP, ENTER
Sensor / Signal Input	
Type (User Programmable)	Thermocouple : J, K, T, R, S, B, N RTD Pt100, 3 wire DC Linear : 0-20 mA, 4-20 mA 0-50 mV, 0-200 mV 0-1.25 V, 0-5 V, 0-10 V, 1-5 V
Corrections	<ul style="list-style-type: none"> <li>• In-built Cold-Junction Compensation for Thermocouples</li> <li>• In-built Lead Resistance Compensation for RTD (Upto 22 Ohms in each lead)</li> </ul>
Accuracy	For Thermocouples & RTD : $\pm 0.25\%$ of reading $\pm 1^\circ\text{C}$ For DC Linear Volts / Current : $\pm 0.25\%$ of reading $\pm 1$ LSD
Display Range	Refer Table 1 for Thermocouples & RTD Inputs Adjustable from -1999 to 9999 Counts for DC Linear mA/mV/V
Display Resolution (User Programmable)	Thermocouples & RTD Pt100 : 0.1 / $1^\circ\text{C}$ DC Linear Volts / Current : 0.001 / 0.01 / 0.1 / 1 Counts
Zero Offset	User Adjustable over Full Range

ADC	16 Bit ( $\pm 32,768$ Counts), Sigma-Delta ( $\Sigma\Delta$ )
Sampling Time	200mS (5 Samples per Second)
Input Resistance	> 8 MOhm
Common Mode Rejection	> 100dB at 50/60 Hz
Signal Conditioning	L-C Analog Filter with Programmable Digital Low-Pass Filter
<b>Alarms</b>	
Numbers	2, Independent
Programmable Parameters	Mode : Process Low, Process High, Deviation, Window Logic : Normal, Reverse Hysteresis : 1 to 999 Unit Counts Inhibit : No, Yes
Outputs (Optional)	Relay Change-over Contacts or SSR Drive (Jumper Selectable) Output-2 (OP-2) for Alarm-1, Output-3 (OP-3) for Alarm-2
<b>Retransmission</b>	
Parameter Type	Process Value (PV) or Setpoint (SP)
Parameter Value	User Settable through 'Range Low' & 'Range High' Parameters
Output Signal	DC Volts (0-5/10 V) or DC Current (0/4-20 mA)
<b>Control</b>	
Type	Self Tune PID, ON-OFF, Pulsed ON-OFF
Mode	Heat only, Cool only, Heat & Cool
Control Parameters	<ul style="list-style-type: none"> <li>• ON-OFF : Hysteresis</li> <li>• Self Tune PID : Proportional Band, Integral Time, Derivative Time, Cycle Time, Relative Cool Gain, Power Low, Power High, Overshoot Inhibit</li> <li>• Pulsed ON-OFF : Hysteresis, Pulse Period, Pulse-ON Time</li> </ul>
<b>Setpoint Profile</b>	
Segments	4 / 8 / 12 / 16, Free Formeable Ramp or Soak
Hold Back Band	Common for entire Profile or Independent for each Segment
Repeat Cycles	1 to 9999
Power-fail Recovery	User Programable for Resumption or Abortion of Profile

## Outputs

(Refer Table 2 : Output Option Selection & Function Assignments)

Relay	Contact Type : Potential-free Change-over Contacts Contact Rating : 5A Resistive @ 120/240 Vac Contact Life : > 5,00,000 Operations at Rated Voltage / Current
SSR Drive	> 4.2 VDC into 1KOhm Minimum
DC Linear	Voltage : 0-5V, 0-10V (into 1KOhm Minimum) Current : 0-20mA, 4-20mA (into 500 Ohm Maximum)
<b>Serial Communication</b>	
Port	RS485, 2-wire, Half Duplex, Start-Stop Synchronized
Protocol	Modbus RTU
Baud Rate	Settable : 4800, 9600, 19200, 38400, 57600
Parity	Settable : None, Even, Odd
Max. Units per Loop	31
Max. Distance	1200 Metres
<b>Power Supply</b>	
Type	Switch Mode (SMPS)
Line Voltage	Standard : 85~264 VAC, 50/60Hz Optional : 18~36 VDC
Consumption	5VA Max
<b>Physical</b>	
Mounting	Plug-in with Panel Mounting Clamps
Overall Dimensions	48(H) X 48(W) X 110(D), mm      96(H) X 96(W) X 65(D), mm
Panel Cutout	45(H) X 45(W), mm      92(H) X 92(W), mm
Terminals	Screw Type
Weight	48 X 48 : 225 gm, Appx.,      96 X 96 : 400 gm, Appx.
<b>Environmental</b>	
Operating Ambient	0~55°C & 5~90%RH Non-condensing
Storage Temperature	-10 to +70°C
EMC Standards	EN50081-2 & EN 50082-2 Generic Stds for Industrial Environment
Safety Standards	Meets EN61010, Installation Catagory II
Atmospheres	Not Suitable for use in Corrosive or Explosive Atmospheres. The Panel in which the Instrument is Mounted must be free of Electrically Conductive Pollution.

## Back Panel Terminations

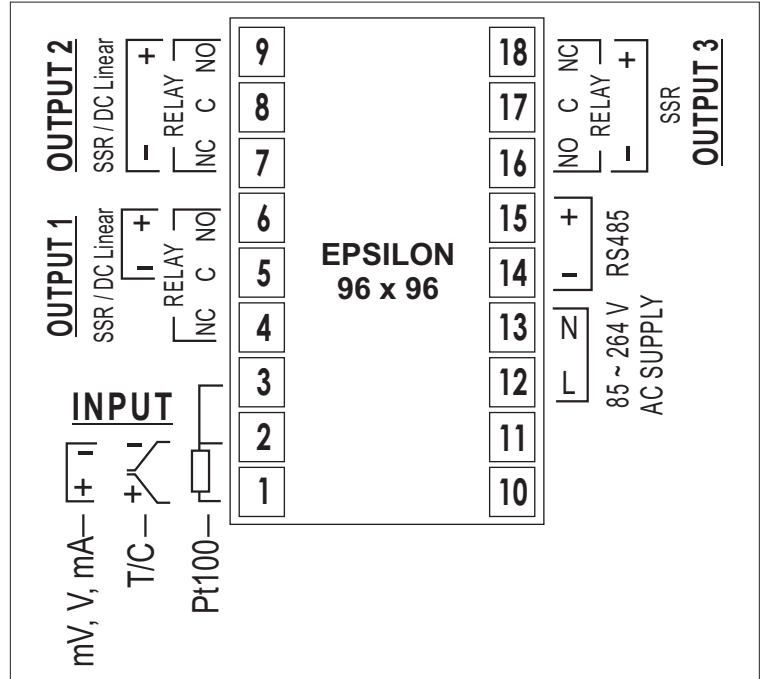
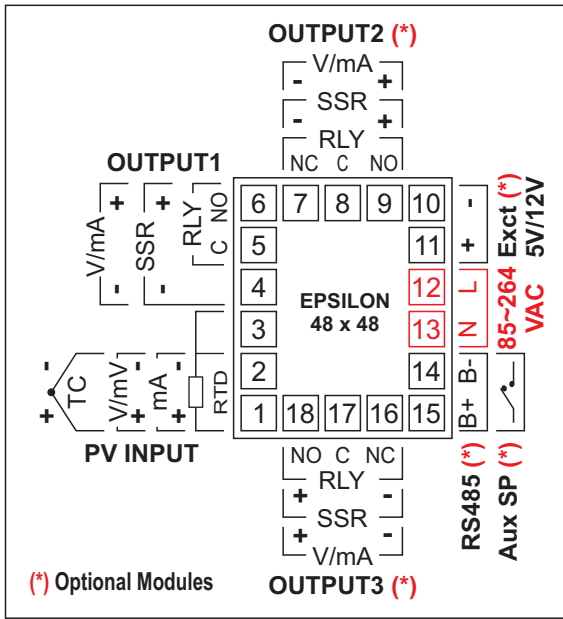

**Table 1 : Temperature Ranges for Thermocouples & RTD**

Input Type	Range (Min. to Max.)
Type J Thermocouple (Fe-K)	0 to +960°C / +32 to +1760°F
Type K Thermocouple (Cr-Al)	-200 to +1376°C / -328 to +2508°F
Type T Thermocouple (Cu-Con)	-200 to +385°C / -328 to +725°F
Type R Thermocouple (Pt/Pt-Rh13%)	0 to +1770°C / +32 to +3218°F
Type S Thermocouple (Pt/Pt-Rh10%)	0 to +1765°C / +32 to +3209°F
Type B Thermocouple	0 to +1825°C / +32 to +3092°F
Type N Thermocouple	0 to +1300°C / +32 to +2372°F
3-wire, RTD Pt100	-199 to +600°C / -328 to +1112°F or -199.9 to 600.0°C / -199.9 to 999.9°F

## Table 2 : Output Option Selection & Function Assignments

	Available Options (Specify while Ordering)	Function Assignments (User Programmable)
Output-1 (OP-1)	<input type="checkbox"/> Relay, SSR & 0/4-20 mA (Jumper Selectable) <input type="checkbox"/> Relay, SSR & 0-5/10 V (Jumper Selectable)	✓ Main Control Output
Output-2 (OP-2)	<input type="checkbox"/> Relay, SSR (Jumper Selectable) <input type="checkbox"/> 0-5/10 V <input type="checkbox"/> 0/4-20 mA	✓ Cool Control Output ✓ Alarm-1 Output ✓ End of Profile Output ✓ Auxiliary Control Output ✓ Blower Control Output
Output-3 (OP-3)	<input type="checkbox"/> Relay, SSR (Jumper Selectable) <input type="checkbox"/> 0-5/10 V <input type="checkbox"/> 0/4-20 mA	✓ Alarm-2 Output ✓ End of Profile Output ✓ Retransmission Output

### Ordering Code

Input*		Output 1***		Output 2		Output 3		Power Supply		Options		Size	
TC	Thermocouple	1C	Relay	0	None	0	None	0	85~264 VAC	N	None	48	48 X 48
PT	RTD Pt100	1V	Relay	1	Relay**	1	Relay**			S	Serial Port	96	96 X 96
LV	Linear Voltage	2C	SSR	2	SSR**	2	SSR**			A	Auxiliary SP		
LC	Linear Current	2V	SSR	3	0-5/10 V	3	0-5/10 V						
		3V	0-5/10 V	4	0/4-20 mA	4	0/4-20 mA						
		4C	0/4-20 mA										

#### Example Code **TC-4C-1-4-0-A-48**

Thermocouple Input, Output-1 0/4-20 mA, Output-2 Relay, Output-3 0/4-20 mA (Retransmission), 85~264 VAC Supply, Auxiliary Setpoint, 48 X 48

\* Input type is universal and requires appropriate jumper settings. The ordering code only implies the factory settings at the time of dispatch.

\*\* Relay and SSR selection is jumper settable by user. The ordering code only implies the factory settings at the time of dispatch if Relay/SSR output option is ordered .

\*\*\* Output-1 is universal with ordering code comprising two characters. The first character specifies the factory jumper setting and the second character specifies one of the following output options.

<b>C</b>	Relay, SSR & 0/4-20 mA
<b>V</b>	Relay, SSR & 0-5/10 V